

CHESTER HOIST

WORM DRIVE HOIST
DATA SHEET E-17AS

CAPACITY 5 TON

STANDARD HEADROOM
HAND GEARED TROLLEY - T

SINGLE HOOK MONORAIL
2-PART DOUBLE

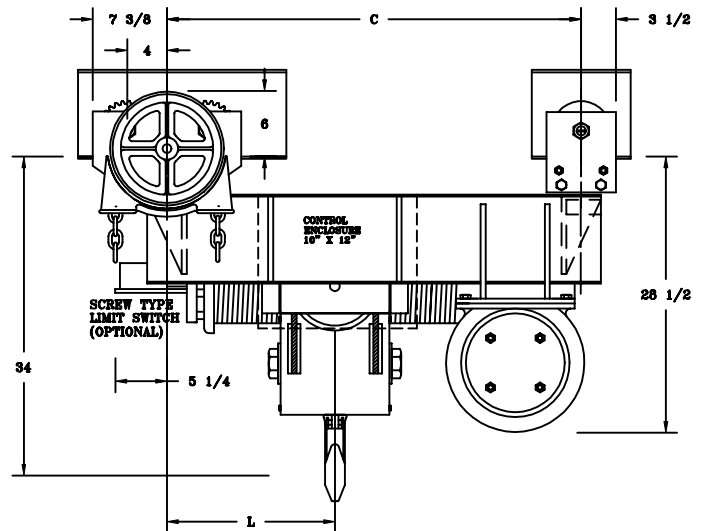
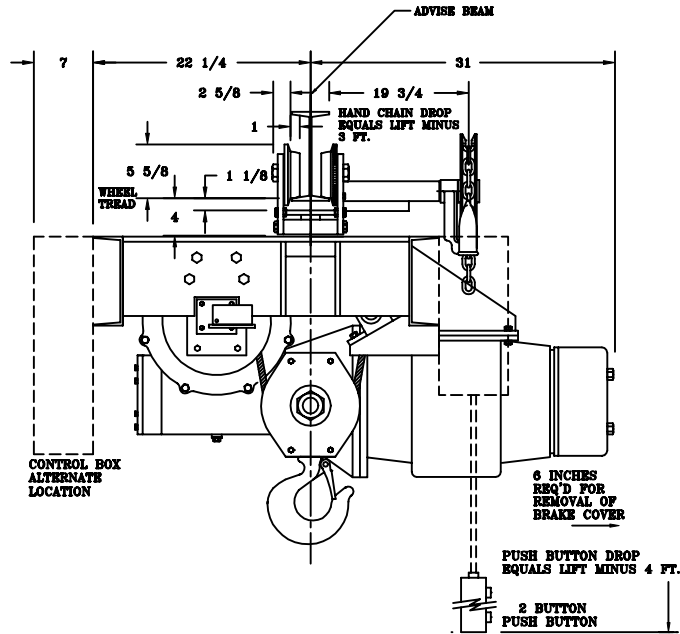

ALL DIMENSIONS IN INCHES

MODEL NUMBER	CAPACITY (lbs.)	SPEED (fpm)	LIFT (ft.)	REEVING	MOTOR (hp)	C	L	ST'D. I-BEAM		MIN. CURVE RADIUS (ft.)	APPROX. WT. (lbs.)
								SIZE	CLEAR*		
WDGT-1106S	10000	20	15	2PD-7/16	10 @ 1200	42 1/2	17 1/2	7-24	7/16	6	2200
WDGT-1107S	10000	20	25	2PD-7/16	10 @ 1200	51 1/2	22	7-24	7/16	6	2300
WDGT-1108S	10000	20	35	2PD-7/16	10 @ 1200	57 1/2	25	7-24	7/16	6	2400
WDGT-1108AS	10000	20	55	2PD-7/16	10 @ 1200	72 1/2	32 1/2	7-24	7/16	6	2600
WDGT-1108BS	10000	20	65	2PD-3/8E	10 @ 1200	72 1/2	32 1/2	7-24	7/16	6	2600
WDGT-1108CS	10000	20	95	2PD-3/8E	10 @ 1200	93 1/2	42 1/2	7-24	7/16	6	2850
WDGT-1109S	10000	30	15	2PD-7/16	15 @ 1800	42 1/2	17 1/2	7-24	7/16	6	2200
WDGT-1110S	10000	30	25	2PD-7/16	15 @ 1800	51 1/2	22	7-24	7/16	6	2300
WDGT-1111S	10000	30	35	2PD-7/16	15 @ 1800	57 1/2	25	7-24	7/16	6	2400
WDGT-1111AS	10000	30	55	2PD-7/16	15 @ 1800	72 1/2	32 1/2	7-24	7/16	6	2600
WDGT-1111BS	10000	30	65	2PD-3/8E	15 @ 1800	72 1/2	32 1/2	7-24	7/16	6	2600
WDGT-1111CS	10000	30	95	2PD-3/8E	15 @ 1800	93 1/2	42 1/2	7-24	7/16	6	2850

* CLEARANCE BASED ON MAX. "S" BEAM SIZE 24" @ 121 LBS.
TROLLEYS FOR OTHER I-BEAMS AND PATENTED TRACKS ARE AVAILABLE.
NOTE: WHEN USING SCREW TYPE LIMIT SWITCH ADD 1 INCH TO HEADROOM.