

# CHESTER HOIST

WORM DRIVE HOIST  
DATA SHEET E-37AS

## CAPACITY 3-4-5 TON

STANDARD HEADROOM  
HAND GEARED TROLLEY-T

TWIN HOOK MONORAIL  
2-PART SINGLE

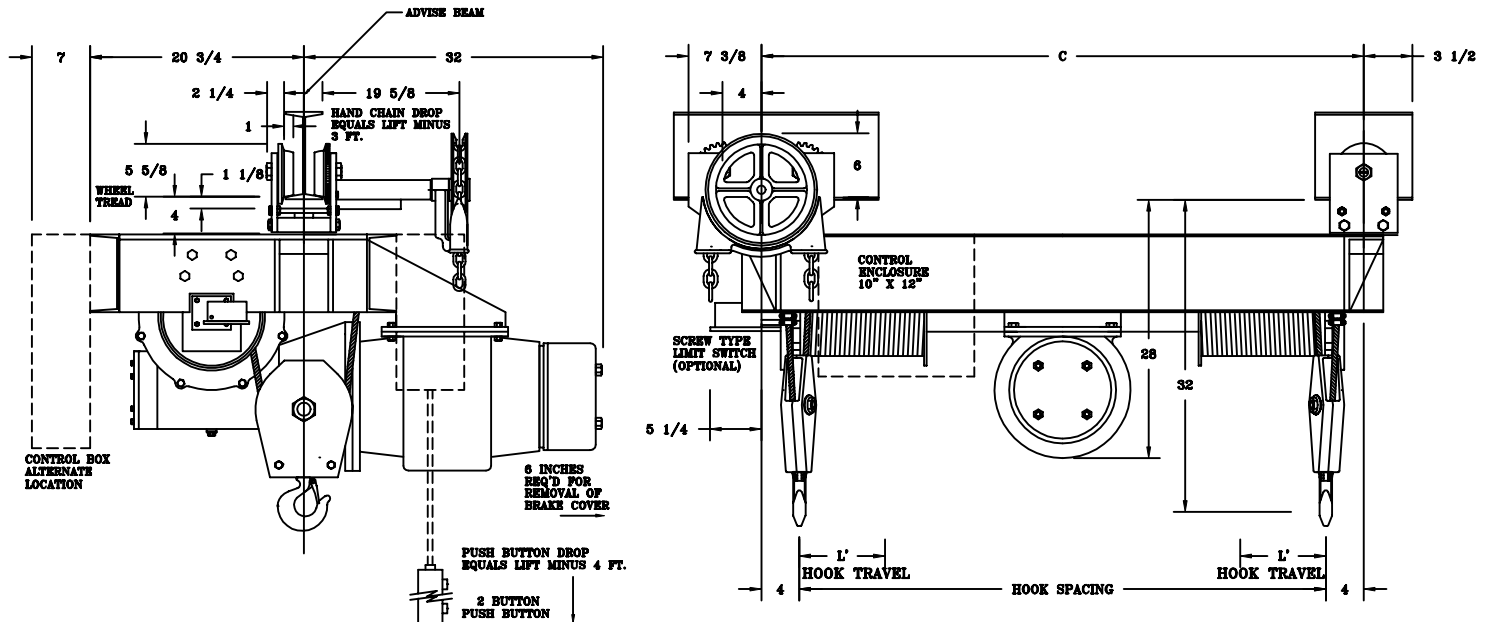

ALL DIMENSIONS IN INCHES

MODEL NUMBER	CAPACITY (lbs.)	SPEED (fpm)	LIFT (ft.)	REEVING	MOTOR (hp)	C	L'	MAX. HOOK SPACING	MIN. HOOK SPACING	ST'D. I-BEAM		APPROX. WT. (lbs.)
										SIZE	CLEAR*	
WDGT-363S	6000	32	20	2PS-3/8	10 @ 1800	50	6	144	42	7-24	7/16	1300
WDGT-364S	6000	32	40	2PS-3/8	10 @ 1800	67	10 1/2	144	59	7-24	7/16	1450
WDGT-365S	6000	32	60	2PS-3/8	10 @ 1800	85	14 1/2	144	77	7-24	7/16	1600
WDGT-383S	8000	21	20	2PS-3/8	10 @ 1200	50	6	144	42	7-24	7/16	1300
WDGT-384S	8000	21	40	2PS-3/8	10 @ 1200	67	10 1/2	144	59	7-24	7/16	1450
WDGT-385S	8000	21	60	2PS-3/8	10 @ 1200	85	14 1/2	144	77	7-24	7/16	1600
WDGT-3106S	10000	30	20	2PS-7/16	15 @ 1800	50	6	144	42	7-24	7/16	1750
WDGT-3107S	10000	30	40	2PS-7/16	15 @ 1800	67	10 1/2	144	59	7-24	7/16	1900
WDGT-3108S	10000	30	60	2PS-7/16	15 @ 1800	85	14 1/2	144	77	7-24	7/16	2050

\* CLEARANCE BASED ON MAX. "S" BEAM SIZE 24" @ 121 LBS.  
TROLLEYS FOR OTHER I-BEAMS AND PATENTED TRACKS ARE AVAILABLE.  
"C" DIMENSION AND WEIGHTS BASED ON MIN. HOOK SPACING  
NOTE: WHEN USING SCREW TYPE LIMIT SWITCH ADD 1 INCH TO HEADROOM.