

CHESTER HOIST

WORM DRIVE HOIST
DATA SHEET E-98AS

CAPACITY 5 TON

INTERMEDIATE HEADROOM
MOTORIZED TROLLEY TYPE - S

SINGLE HOOK MONORAIL
4-PART SINGLE

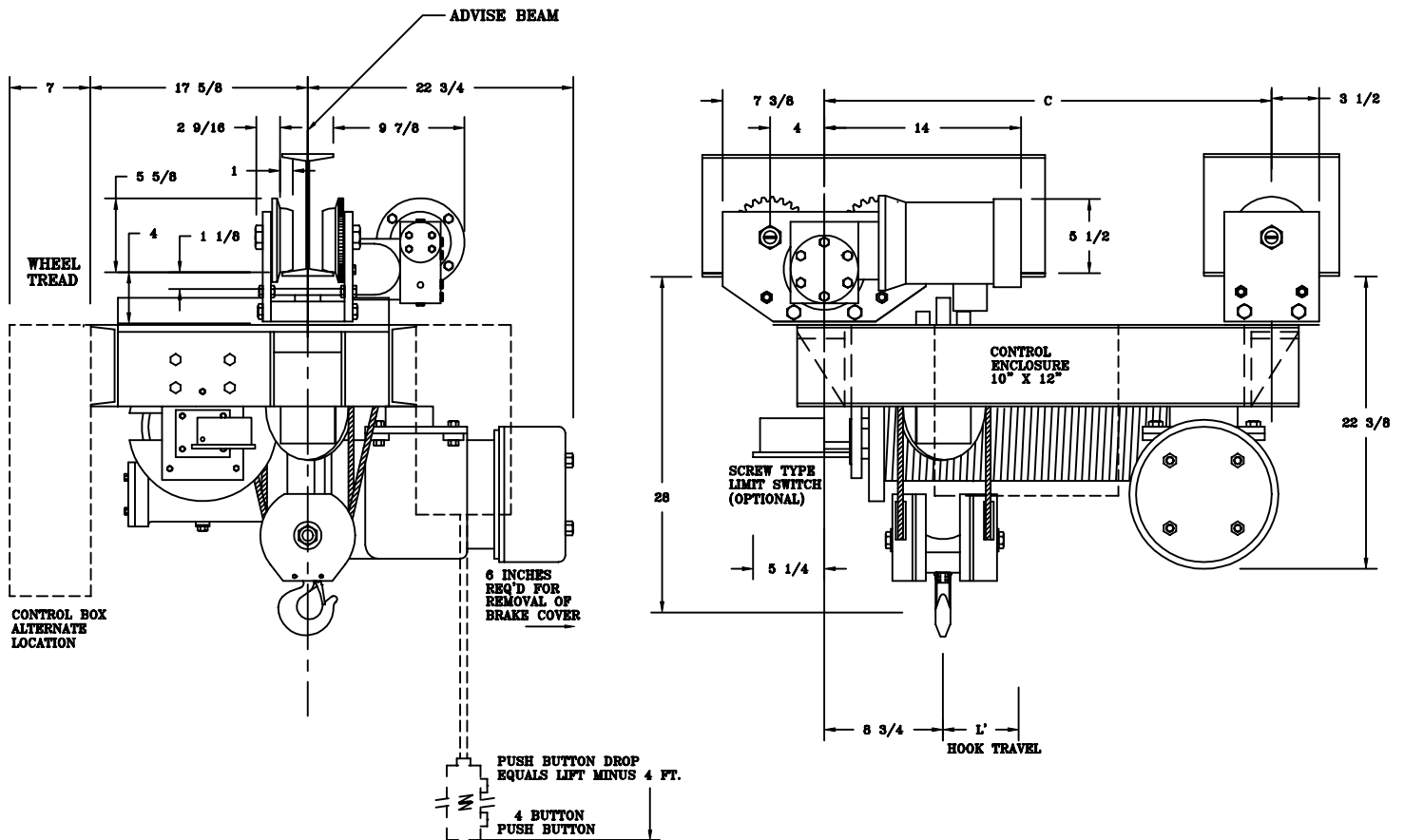

ALL DIMENSIONS IN INCHES

MODEL NUMBER	CAPACITY (lbs.)	SPEED (fpm)	LIFT (ft.)	REEVING	MOTOR (hp)	C	L'	ST'D. I-BEAM		MIN. CURVE RADIUS (ft.)	APPROX. WT. (lbs.)
								SIZE	CLEAR*		
WDMT-1104WS	10000	20	23	4PS-3/8E	10 @ 1800	34 7/8	5	7-24	7/16	6	1200
WDMT-1105WS	10000	20	35	4PS-3/8E	10 @ 1800	43 5/8	7	7-24	7/16	6	1300
WDMT-1105WAS	10000	20	45	4PS-3/8E	10 @ 1800	53 5/8	10	7-24	7/16	6	1400

* CLEARANCE BASED ON MAX. "S" BEAM SIZE 24" @ 121 LBS.
TROLLEYS FOR OTHER I-BEAMS AND PATENTED TRACKS ARE AVAILABLE.
NOTE: WHEN USING SCREW TYPE LIMIT SWITCH ADD 1 INCH TO HEADROOM.