

CHESTER HOIST

WORM DRIVE HOIST
DATA SHEET E-96AS

CAPACITY 6-7 1/2 TON

STANDARD HEADROOM
MOTORIZED TROLLEY - S

SINGLE HOOK MONORAIL
4-PART SINGLE

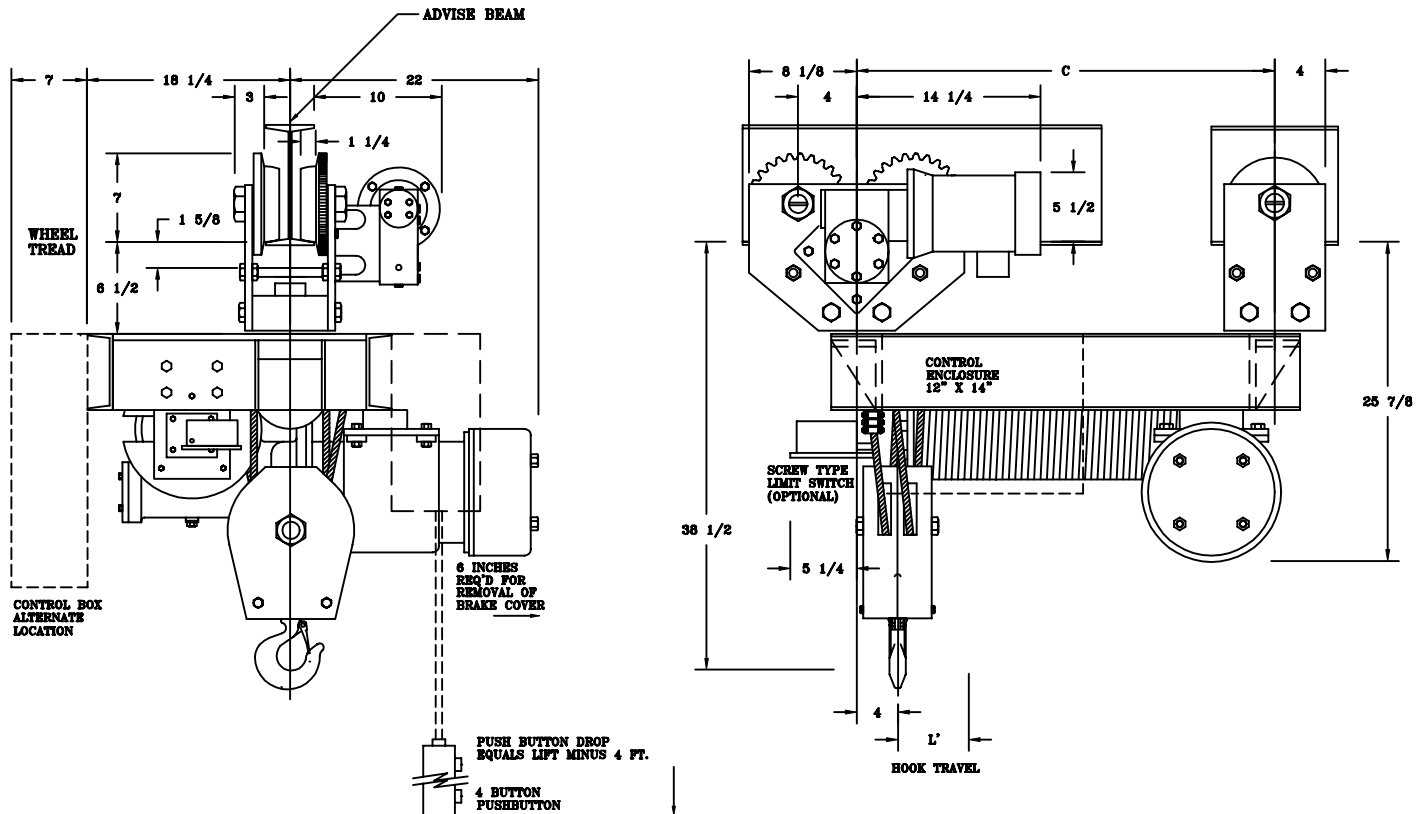

ALL DIMENSIONS IN INCHES

MODEL NUMBER	CAPACITY (lbs.)	SPEED (fpm)	LIFT (ft.)	REEVING	MOTOR (hp)	C	L'	ST'D. I-BEAM		MIN. CURVE RADIUS (ft.)	APPROX. WT. (lbs.)
								SIZE	CLEAR*		
WDMT-1120S	12000	10	10	4PS-7/16	6 @ 1200	26 1/8	3	8-24	5/8	6	1150
WDMT-1121S	12000	10	20	4PS-7/16	6 @ 1200	34 7/8	5 1/4	8-24	5/8	6	1200
WDMT-1122S	12000	10	30	4PS-7/16	6 @ 1200	43 5/8	7 1/4	8-24	5/8	6	1250
WDMT-1122AS	12000	10	40	4PS-7/16	6 @ 1200	53 5/8	9 1/2	8-24	5/8	6	1250
WDMT-1122BS	12000	10	60	4PS-7/16	6 @ 1200	70 1/8	15 1/2	8-24	5/8	6	1300
WDMT-1153S	15000	10	20	4PS-7/16E	7 1/2 @ 1200	34 7/8	5 1/4	8-24	5/8	6	1200

* CLEARANCE BASED ON MAX. "S" BEAM SIZE 24" @ 121 LBS.
TROLLEYS FOR OTHER I-BEAMS AND PATENTED TRACKS ARE AVAILABLE.
NOTE: WHEN USING SCREW TYPE LIMIT SWITCH ADD 1 INCH TO HEADROOM.