



THE POWER TO PERFORM

Columbus McKinnon Corporation, Entertainment Products Division
140 John James Audubon Parkway, Amherst, NY 14228
Phone 716 689 5400 | Fax 716 689 5644
www.cm-et.com



Material Handling - Easily and Safely





ENTERTAINMENT TECHNOLOGY



CM Entertainment Technology. Built to Perform, Built to Last.

Columbus McKinnon, with over 130 years of Rigging and Material Handling experience, is the leading manufacturer of lifting and pulling products.

The CM Lodestar-*“The Industry Workhorse”* has been going strong for over 50 years. CM recently held a year long celebration to commemorate the production of the one millionth Lodestar.

Broad Product Offering

The entertainment industry is certainly more than one dimensional, and the same can be said of the CM product line. We offer everything you need for material handling. A wide variety of electric and manual chain hoists are available as well as accessories and rigging hardware for almost every job.

Worldwide Distribution

With Distributors worldwide, you're never far from CM quality products, parts or service. Plus, our training, service and application support are all part of our *“Built to Last”* product philosophy.

Built to Perform

Along with our Lifetime Warranty- The Industry's Best, our commitment to new products and innovation continues:

- ¥Single to variable speed
- ¥Manual to electric
- ¥Small to large capacities
- ¥Accessories

Wherever you go, regardless of the venue, CM Entertainment Technology is there.

Whether it's touring, corporate, worship, theatrical or film, **CM-ET** has the high quality rigging products to meet all your needs for a great performance.



The Power To Perform



CATALOG CONTENT

Lodestar	1	11	Stac Chain/Shackles & Accessories
ShowPro Direct Control	3	13	Prostar And Lodestar Engineering Specifications
Lodestar BGV-C1	5	15	Hoist Maintenance & Training
Lodestar Features	7	17	Other Quality CM Products
Prostar	9	21	Theatrical Shackles

CM

LODESTAR®

LODESTAR LOW VOLTAGE CONTROL

The **CM Lodestar** is the most durable chain hoist in the market today. Its reliability is unsurpassed in the entertainment industry. The CM Lodestar has features that allow the hoist to be used in all types of venues and applications. That's why The CM Lodestar has become the Riggers Choice.

- **Capacities** - 1/8 to 2 tons
- **Speeds** - 8 to 64 F.P.M. 30 at 60 Hz.
- **Lift** - 60 ft. standard (other lifts available).
- **Voltages** - Single-phase & three-phase available, see the engineering specifications page for voltages offered.



KEY FEATURES

- ✦ **Brake** - AC electromechanical brake, field tested, proven design in over 1 million Lodestars worldwide.
- ✦ **Low Voltage Control** - 110 Volt for long cable runs without voltage drop 24 and 48 Volt optional.
- ✦ **Housing** - Lightweight, cast aluminum, durable and strong black powder coated finish for low visibility.
- ✦ **Gearing** - Helical design for long wear life and smooth operation.
- ✦ **Load Chain** - Designed and manufactured by Columbus McKinnon. Zinc plated to protect against corrosion. Optional black finish available.
- ✦ **Duty Cycle** - H-4 duty rated, designed for heavy duty application..
- ✦ **Lifetime Warranty** - The industry's best.

STANDARD FEATURES

- ✦ **Electrical** - Finger safe wiring meets all electrical codes-quick change plugs allow for voltages from 208 thru 460. Prevents improper voltage connections which can cause hoist damage.
- ✦ **Adjustable Limit Switch**- Prevents load from overtravel.
- ✦ **Overload protection** - Helps prevent lifting of dangerous overloads.
- ✦ **Metric Rated.**
- ✦ **Meets requirements** - Meets or exceeds world standards.
- ✦ **Road Ready** - Fits in standard flight cases.

OPTIONAL FEATURES

- ✦ **Double Brake** - Double DC brake. Field installation kit available.
- ✦ **SilentStar**- Retro kits available. Brake allows for quiet operation.
- ✦ **Chain Bags** - Cloth type bags-easy to mount.
- ✦ **Alloy Latchlok® hooks**- remains locked until released by the operator, even if chain goes slack.

Specifications

Capacity (Tons)	Model	No. of Chains	Motor (H.P.)	Lift Speed (F.P.M.)	Wt. Less Chain (lbs.)	Wt. 1ft of Chain (lbs.)	Full Load Amps	
							1-Phase	3-Phase
1/8	AA	1	1/2	60	52	.58	8.0	1.2* / 1.7
1/4	B	1	1/4	16	52	.58	5.2	1.1* / 1.8
1/4	C	1	1/2	32	54	.58	8.0	1.2* / 1.7
1/2	F	1	1/2	16	54	.58	8.0	1.2* / 1.7
1/2	J	1	1	32	100	.92	13	2.3* / 3.8
1/2	JJ	1	2	64	100	.92	-	6* / 11.3
1	L	1	1	16	100	.92	13	2.3* / 3.8
1	LL	1	2	32	100	.92	-	6* / 11.3
2	R	2	1	8	102	1.84	13	2.3* / 3.8
2	RR	2	2	16	102	1.84	-	6* / 11.3

Other capacities up to 3 tons available upon request

*415 Volt operation 220 Volt operation



SHOWPRO DIRECT CONTROL

From industry leader Columbus McKinnon, the **CM ShowPro Direct Control** electric chain hoist is designed to meet all basic rigging needs.

- **Capacities** - 1/2, 1, 2 ton
- **Speeds** - 16, 8 F.P.M.
- **Lift** - 60 ft. (other lifts available)
- **Voltages** - 230/460 three-phase available.

KEY FEATURES

- ✦ **Brake** - AC electromechanical field tested, proven design.
- ✦ **Housing** - Lightweight, cast aluminum, durable and strong black powder coated finish for low visibility.
- ✦ **Load Chain** - Designed and manufactured by CM. Black finish.
- ✦ **Duty Cycle** - H-4 duty rated, designed for heavy duty application.
- ✦ **Liftwheel** - 5 pocket design for smooth quiet operation.

STANDARD FEATURES

- ✦ **Overload protection** - Helps prevent lifting of dangerous overloads.
- ✦ **Metric Rated.**
- ✦ **Meets requirements** - Meets or exceeds world standards.
- ✦ **Road Ready** - Fits in standard flight cases.
- ✦ **Lifetime Warranty** - The industry's best.

OPTIONAL FEATURES

- ✦ **Double Brake** - Double DC brake. Field installation kit available.
- ✦ **Chain Bags** - Cloth type bags-easy to mount.

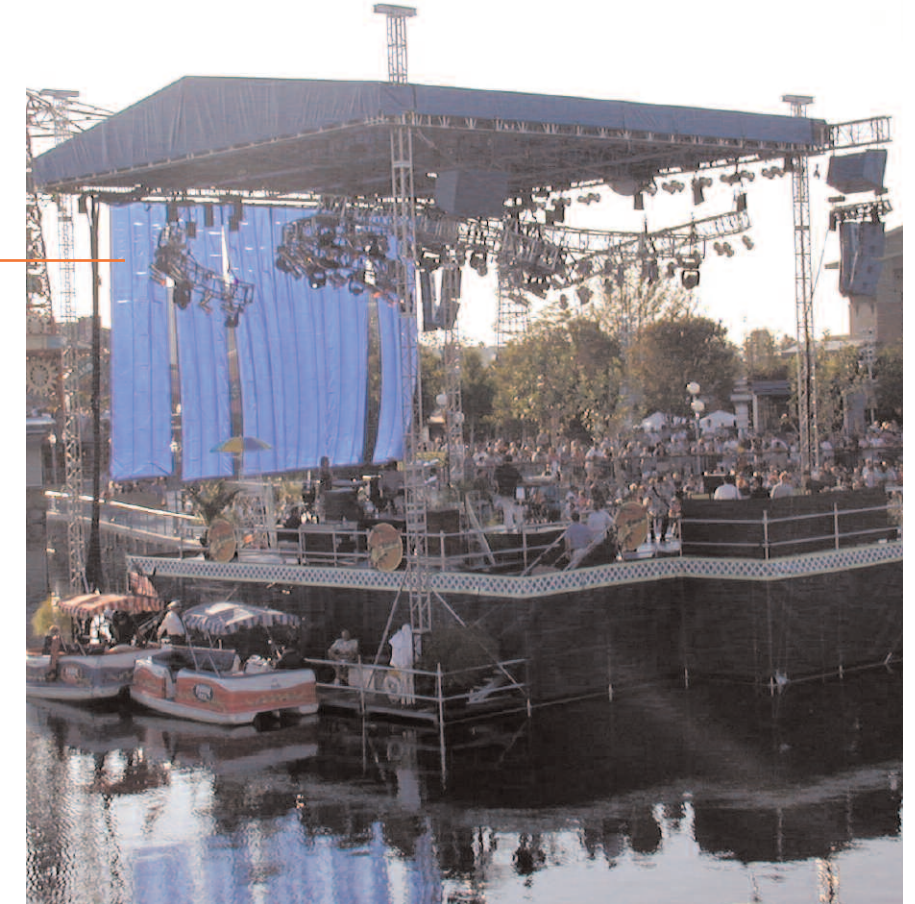

Specifications

Capacity (Ton)	No. of Chains	Motor (H.P.)	Lift Speed (F.P.M.)	Lift (Ft.)	Approx. Ship Wt. w/66ft. Lift (lbs.)	Motor Voltage / Phase / hertz Amps			
1/2	1	1/2	16	66	119	230/3/60	1.9	460/3/60	.95
1	1	1	16	66	126	230/3/60	3.0	460/3/60	1.5
2	2	1	8	66	186	230/3/60	3.0	460/3/60	1.5

Standard operational 3-phase voltages 208,230,380,415, 460 @ 50 or 60 Hertz.



LODESTAR BGV-C1

The **CM Lodestar**, is now available with several new and exciting options which meet the BGV-C1 German standard for entertainment rigging. It can also be adapted to operate from BGV-C1 control systems.

- **Capacities** - 275 lbs. to 1.5 tons
- **Speeds** - 8 to 64 F.P.M. rated at 60 Hz.
- **Lift** - 60 ft. standard (other lifts available).
- **Voltages** - three-phase available, see the engineering specifications page for voltages offered.



KEY FEATURES

- **10:1 Design Factor**
- **Double Brake** - Double DC brake with 50-millisecond delay between first and second brake actuation for reduced stress loading during operation and easy identification of any problems with the first brake. Designed to be easily isolated for individual inspection.
- **Limit Switches** - Dual semi-adjustable limit switches. Emergency secondary limit switch operation triggers mainline contactor in controller to shut the entire system down.
- **Electronic Underload & Overload Protection** - Fitted with integral load monitoring components to warn when a dangerous overload or slack chain situation occurs.
- **Controls** - Fitted with industrial grade logic controller for management of all integral safety features and communication with external control devices.
- **Encoder** - Hoist fitted with high resolution encoder for accurate positioning information feedback to computerized control system.
- **Housing** - Lightweight, cast aluminum, durable and strong black powder coated finish for low visibility.
- **Gearing** - Helical design for long wear life and smooth operation.
- **Load Chain** - Designed and manufactured by Columbus McKinnon. Zinc plated to protect against corrosion. Optional black finish available.
- **Duty Cycle** - H-4 duty rated, designed for heavy duty application.
- **Lifetime Warranty** - The industry's best.

STANDARD FEATURES

- **Electrical** - Finger safe wiring meets all electrical codes-quick change plugs allow for voltages from 208 thru 460. Prevents improper voltage connections which can cause hoist damage.
- **Metric Rated.**
- **Meets requirements** - Meets or exceeds world standards.
- **Road Ready** - Fits in standard flight cases.

OPTIONAL FEATURES

- **Chain Bags** - Cloth type bags-easy to mount.
- **Alloy latchlok® hooks**- remains locked until released by the operator, even if chain goes slack.
- **D8+ Available.**

Specifications

Capacity (Tons)	Model	No. of Chains	Motor (H.P.)	Lift Speed (F.P.M.)	Wt. Less Chain (lbs)	Wt. 1ft of Chain (lbs)	Full Load Amps 3-Phase
1/8	C1-B	1	1/4	16	75	.585	1.1* / 1.8
1/4	C1-F	1	1/2	16	75	.585	1.1* / 1.8
1/2	C1-L	1	1	16	115	.926	2.3* / 3.8
1/2	C1-JJ	1	2	64	115	.926	6* / 11.3
1/2	C1-LL	1	2	32	115	.926	6* / 11.3
1	C1-R	2	1	8	115	1.852	2.3* / 3.8
1 1/2	C1-RR	2	2	16	125	1.852	3.6* / 11.3

*415 Volt operation 220 Volt operation

Other capacities up to 3 tons available upon request

LODESTAR FEATURES



Load Chain

Sizes Available from
(1/4 to 5/16)

- Meets or exceeds many national and International standards.
- Zinc plated supplied as standard, black phosphate finish available.
- 100% proof tested.



Overload Protector

- Designed to prevent lifting of excessive overloads.
- Color coded by capacity for easy identification.



CM Alloy Latchlok® Hooks

Latchlok® hooks combine innovative design and solid alloy steel. I-beam construction offers more reliable performance than any other hook on the market.

- One-hand operation and recessed push-button thumb release for smooth and dependable opening.
- Hook remains locked until released by the operator, even if chain goes slack.
- Sturdy forged heat treated I-beam construction for strong yet lightweight hooks.
- Lifetime warranty.
- Made in U.S.A.

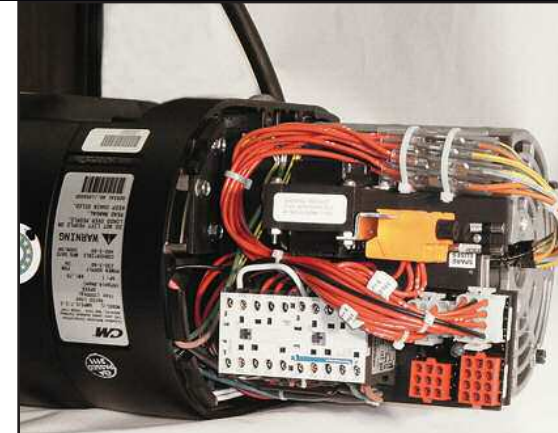

Control Panel

Provides easy access to controls, plug & play connectors allow for quick voltage Change for dual voltage motors.

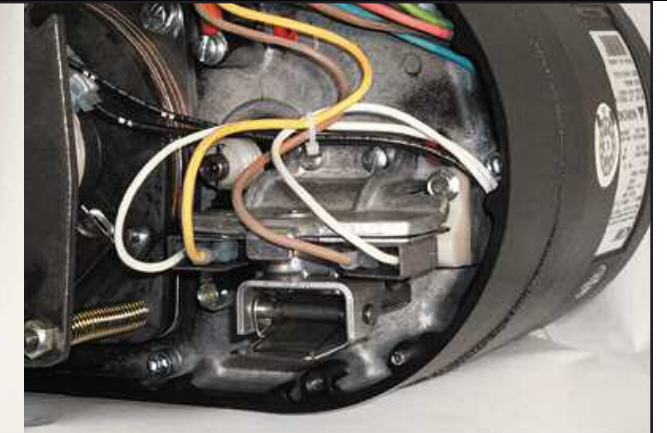

Limit Switch

Adjustable screw limit switch that will automatically stop the hook at any Predetermined point when either hoisting or lifting.

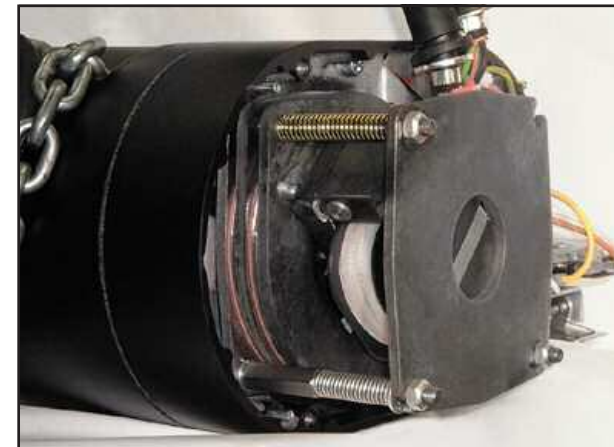

Multiple Disc Motor Brake

Heavy duty electric hoist brake provides positive load control.



Double Brake - Optional

Two independent acting DC brakes for redundant braking.



PROSTAR

The **CM Prostar** models are designed and built for the unique rigging applications encountered at small venues. Lightweight, quiet and portable, the CM Prostar features an overload device that protects the hoist, operator and structure from damaging overloads. Take the stage with the CM Prostar.

- ✦ **Capacities** - 300 to 1000 lbs.
- ✦ **Speeds** - 8 to 40 F.P.M. rated at 50 Hz.-30 will operate at 60Hz..
- ✦ **Lift** - 60 ft is standard.
- ✦ **Voltages** - Single phase and three-phase available, see the engineering specifications page for voltages offered.



KEY FEATURES

- ✦ **Brake** - DC electromechanical brake, non-adjusting for low maintenance and quite operation.
- ✦ **Gearing** - Precision machined gears heat treated for strength and durability.
- ✦ **Chain Guide** - One piece jam free for smooth operation.
- ✦ **Housing** - Lightweight, cast aluminum, durable and strong black powder coated finish for low visibility.
- ✦ **Lift Wheel** - CM patented 10 pocket oblique lift wheel for quiet and smooth operation.
- ✦ **Low Voltage Control** - 110 Volt for long cable runs without voltage drop. 24 and 48 Volt optional.
- ✦ **Load Chain** - Designed and manufactured by Columbus McKinnon. Zinc plated to protect against corrosion. Optional black finish available.
- ✦ **Duty Cycle** - H-4 duty rated, designed for heavy duty application.
- ✦ **Lifetime Warranty** - The industry s best.

STANDARD FEATURES

- ✦ **Chain Stop** - Mounted on load chain prevents over-travel.
- ✦ **Overload protection** - Helps prevent lifting of dangerous overloads.
- ✦ **Metric Rated.**
- ✦ **Meets requirements** - Meets or exceeds world standards.

OPTIONAL FEATURES

- ✦ **Chain Bags** - Cloth type bags-easy to mount.

Specifications

Capacity (lbs)	No. of Chains	Motor (H.P.)	Lift Speed (F.P.M)	Wt. Less Chain (lbs.)	Wt. 1ft of Chain (lbs.)	Full Load Amps	
						1-Phase	3-Phase
300	1	1/6	16	28	.35	3.6	.6* / 1.2
300	1	1/6	16	28	.35		.6* / 1.1
500	1	1/6	16	28	.35		.7* / 1.2
500	1	1/6	12	28	.35	4	-
600	2	1/6	8	36	.7	3.6	.6* / 1.1
600	2	1/6	8	36	.7	3.6	.6* / 1.1
1000	2	1/6	8	36	.7		.7* / 1.2

*415 Volt operation 220 Volt operation



STAC CHAIN / SHACKLES & ACCESSORIES



The CM Special Theatrical Alloy Chain (STAC)

For theatrical rigging applications where bridle adjustability is required.

- ✦ Super Strength - With working limits of 6 tons 1/2 diameter grade 80 alloy material.
- ✦ Heat Treated - Alloy steel provides long life.
- ✦ Fire and Abrasion Resistant.
- ✦ 4:1 Design Factor - Meets or exceeds worldwide standards.
- ✦ Proof Tested - Each link proof tested to assure weld and material integrity.
- ✦ Positive and easy I.D. - Chain embossed with STAC and CM for easy identification as CM alloy. Also tagged with size, grade, reach and working load limit.
- ✦ Versatility - Link accepts up to 3/4 shackle for adjustability.

CM Screw Pin Anchor Shackles

- ✦ Work Load Limits - 1/2 to 43 tons.
- ✦ Size Diameter - 3/16 to 2.
- ✦ Surface Finish - Self colored, painted or galvanized per ASTM.
- ✦ Strength and Abrasion Features - All shackle bodies and pins are forged from special steel, heat treated and tempered to give greater strength and abrasion resistance.
- ✦ Positive and Easy I.D. - All shackles are marked with size (mm and in.) and working load limit in tons.
- ✦ Strength Plus - Ultimate strength equals 5 times working load limit. Proof load equals 2.2 times working load limit.
- ✦ CE Marked.

Wire Rope Clips

Wire rope clips are used to secure the end of wire rope when forming a loop, i.e, for wire rope turn back. Available in mid-grip (double saddle) and single saddle.

Mid-grip clips are available in a drop forged carbon steel material and single saddle clips are available in malleable iron or drop forged carbon steel. Available in sizes up to 1 1/2 .



Lap Links

A quick permanent way to repair general purpose chains. Chain link and attachments are threaded onto the lap link and the link flattened. Available in a variety of sizes with stock diameters from 1/8 thru 5/8 inch chain. **Not to be used for overhead lifting and prohibited for all load securement applications by CVSA.**



Quick Links

Afford quick and easy chain repair and/or attachment of fittings. Easy closing by threading nut onto threaded end. Reusable. Available in stock diameters ranging from 1/8 . to 1/2 . **Not to be used for overhead lifting, and prohibited for all load securement applications by CVSA.**



Shoulder Eye Bolts

- ✦ Forged steel/quenched and tempered.
- ✦ Metric sizes available.
- ✦ Recommended for straight line pull.

Grade 100 Chain

- ✦ Working load limit up to 17 tons.
- ✦ Diameter sizes available from (7/32" to 3/4").
- ✦ Meets or exceeds many National and International standards.
- ✦ 25% higher working load limit when compared to Grade 80.
- ✦ Available as self-colored, or grey thermal dip.
- ✦ Certification included with every drum.
- ✦ 100% proof tested.



Thimbles-Wire Rope

Made specifically for wire rope turn back forming a cable loop. Used in conjunction with wire rope clips. Manufactured of hot rolled steel in accordance with FED. SPEC. FF-T-276. Available in sizes to fit a maximum of 1 1/2 . diameter wire rope.



Turnbuckles

Turnbuckles find many uses to apply tension to wire rope or cable. They are composed of a forged body and two end fittings. End fittings can be eyes, jaws, or hooks. They must, however, be applied only up to loads within their working load limit as specified for the particular end fitting being applied.



Eye Swivels

- ✦ Hot dip galvanized.
- ✦ Ultimate load is 5 times working load limit.
- ✦ Meets the performance requirements of RR-C-271D, Type VII, Class 2.
- ✦ Made in U.S.A.
- ✦ Regular forged eye and eye swivels.



Grade 30 Chain

An economical utility chain for applications which do not require a high strength to weight ratio.

- ✦ Typically used as trim chain or studio chain.
- ✦ Low carbon steel.
- ✦ Diameter sizes available from 3/16 through 1
- ✦ Available as self colored, zinc plated, or hot galvanized.
- ✦ Also available in grades 43, 70, 80 and 100

PROSTAR AND LODESTAR ENGINEERING SPECIFICATIONS



CM Prostar

Dimensions (Inches)

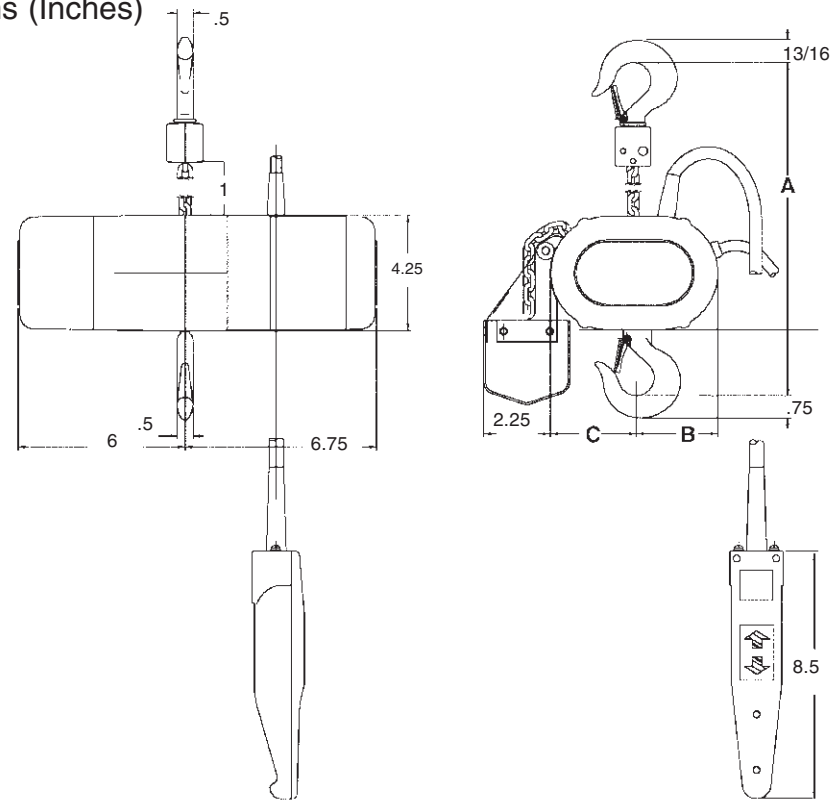

Reeving	A	B	C
Single	11	2 15/16	2 7/8
Double	12 1/8	3 1/2	2 3/8

CM Prostar

Voltages

Model (lbs.)	Lift Speed (F.P.M.)	Single Phase		Three Phase	
300	16	115-1-50/60	220-1-50/60	220-3-50/60	415-3-50/60
300	24	-	-	220-3-50/60	415-3-50/60
300	40	-	-	220-3-50/60	415-3-50/60
500	12	115-1-50/60	220-1-50/60	-	-
500	16	-	-	220-3-50/60	415-3-50/60
500	20	-	-	220-3-50/60	415-3-50/60
600	8	115-1-50/60	220-1-50/60	-	-
600	12	-	-	220-3-50/60	415-3-50/60
1000	6	115-1-50/60	220-1-50/60	-	-
1000	8	-	-	220-3-50/60	415-3-50/60
1000	12	-	-	220-3-50/60	415-3-50/60

CM Lodestar

Dimensions (In.)

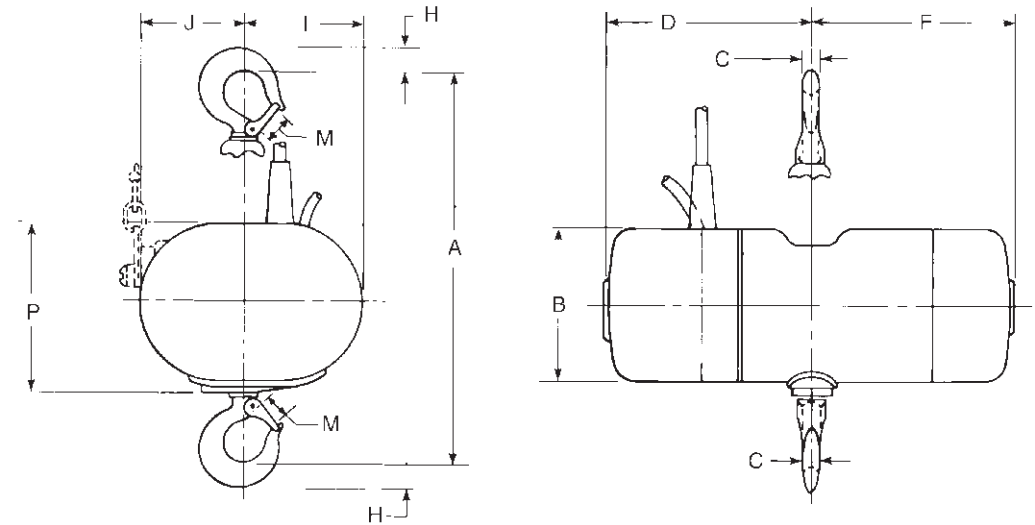

CM Lodestar

Clearance Dimensions (Inches)

	AA, B, C, F, C1-B, C1-F	J, JJ, L, LL, C1-JJ, C1-L, C1-LL	R, RR C1-R, C1-RR
A	16 1/4	18 9/16	29 9/16
B	16 1/8	7 5/8	7 5/8
C	11/16	7/8	1 1/8
D	11	9 1/2	9 1/2
F	7 3/4	10 11/16	10 11/16
H	1	1 3/16	1 1/2
I	4 13/16	7 1/4	6 3/16
J	3 15/16	5 7/16	6 1/2
M	1	1 1/8	1 5/16
P	6 5/8	7 13/16	7 13/16

CM Lodestar

Voltages

Model	Single Phase		Three Phase	
AA	115-1-50/60	220-1-50/60	220/415-3-50/60	575-3-50/60
B	115-1-50/60	220-1-50/60	220/415-3-50/60	575-3-50/60
C	115-1-50/60	220-1-50/60	220/415-3-50/60	575-3-50/60
F	115-1-50/60	220-1-50/60	220/415-3-50/60	575-3-50/60
J	115-1-50/60	220-1-50/60	220/415-3-50/60	575-3-50/60
JJ	-	-	220/415-3-50/60	575-3-50/60
L	115-1-50/60	220-1-50/60	220/415-3-50/60	575-3-50/60
LL	-	-	220/415-3-50/60	575-3-50/60
R	115-1-50/60	220-1-50/60	220/415-3-50/60	575-3-50/60
RR	-	-	220/415-3-50/60	575-3-50/60

*CM Lodestar BGV-C1 and varistar are only available in 220-3-50/60 and 415-3-50/60



HOIST MAINTENANCE & TRAINING

As the leading manufacturer of Chain Motors & Entertainment Rigging Products, CM has been committed to providing reliable products of the highest standard and the training to use them safely.

For the last 25 years, CM has provided training to the Entertainment Industry in the safe Use, Maintenance and Inspection of CM Chain hoists.

Our comprehensive hands-on instruction includes:

- ✦ **Applicable standards**
- ✦ **Design theory**
- ✦ **Electrical theory**
- ✦ **Inspection criteria**
- ✦ **Maintenance procedures**
- ✦ **Complete tear-down and rebuilding of the hoists**
- ✦ **Load testing**
- ✦ **Troubleshooting**

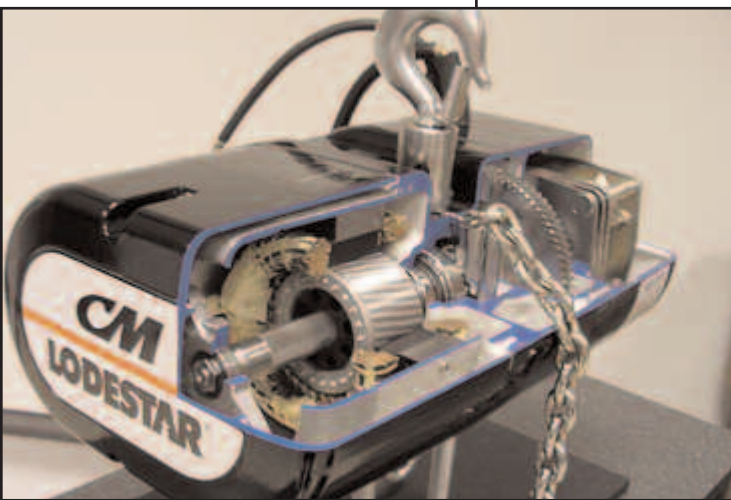

CM has provided thousands of users the information to perform motor maintenance and inspection safely and efficiently.

We provide training through our distributors and directly to a wide variety of user groups. Over the last 25 years, our Motor Schools have been held at rental houses, arenas, theaters, convention halls, lighting/staging/rigging companies and others.

Through our participation in industry trade associations such as GSTA, USITT, and numerous trade shows, we've been leading the way to train a generation of users in the industry.

CM Motor Schools –

“The Original and Only manufacturer training session of its kind for chain motors.”



Our focus is to train the next generation as well.

For more information on training classes, please contact CM.



OTHER QUALITY CM PRODUCTS



Hurricane chain hoist

- ✦ Capacities from 1/2 - 10 tons.
- ✦ Standard Load Limiter for simple, automatic overload protection.
- ✦ The Hurricane's Improved braking system is exceptionally quiet, and improves operational safety and serviceability.
- ✦ Powder coated finish for corrosion protection.
- ✦ All internal gears and pinions are heat treated steel for high strength and long life.
- ✦ Chain Guide and Stripper assures load chain alignment.
- ✦ Precision 4-Pocket Liftwheel is fully machined for better chain fit and reduced wear allowing for accurate movement of the load chain.
- ✦ Alloy steel load chain assures high strength and long wear life.
- ✦ Minimal maintenance, easily disassembled, requiring no special tools.
- ✦ Metric rated.

Series 622 hand chain hoist

- ✦ Capacities from 1,000 lbs. to 10 tons.
- ✦ Simple, efficient, economical design.
- ✦ Compact design, low headroom and lightweight steel construction for easy installation, even in confined spaces.
- ✦ Weston-type load brake requires no lubrication.
- ✦ Hand wheel cover with guide slots minimizes jamming and slipping.
- ✦ Forged swivel hooks with latches reduce twisting of chain and unintentional unhooking of load when chain is slack.
- ✦ Standard hand chain drop is 2 feet less than lift (example: 8 ft. lift hoist has 6 ft. hand chain drop).
- ✦ One-year warranty.
- ✦ Metric rated.

Series 653 lever operated hoist

- ✦ Capacities from 3/4. to 6 tons.
- ✦ Hardened steel load sharing gears.
- ✦ Double pawl arrangement for assured load control.
- ✦ Two chain guide rollers for positive chain engagement.
- ✦ Weston type braking system for positive load control and positioning.
- ✦ Simple one-handed, free chaining for fast load attachment.
- ✦ Hardened steel chain for strength and long wear life.
- ✦ Forged upper and lower hooks with heavy cast steel latches.
- ✦ 5-year warranty against defects in materials and workmanship.
- ✦ Metric rated.
- ✦ Meets ASME B30.21 — Manually Lever Operated Hoist Standard and European CE Standard.

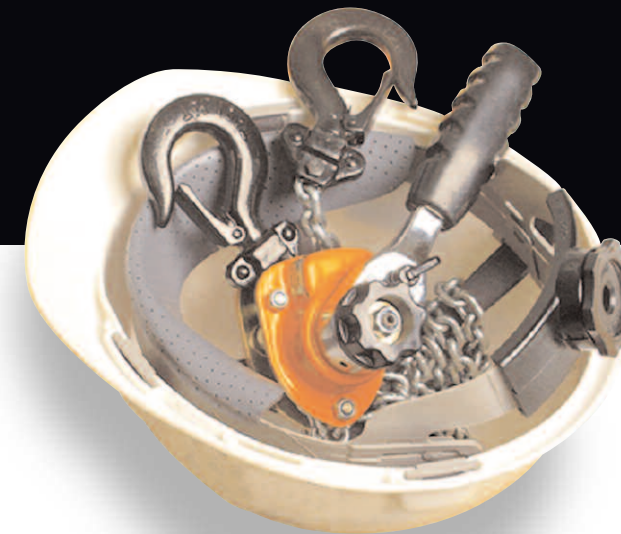

Series 602/603 Hand Chain Hoists

- ✦ Capacities — 500 & 1000 lbs.
- ✦ Plated load chain is standard.
- ✦ Weston-type load brake.
- ✦ Rubber hand grip for better comfort and security.
- ✦ Lightweight design for ease of portability. Use in confined conditions with one-hand operation.
- ✦ Forged upper and lower hooks with latches standard.
- ✦ Impact resistant, all-steel frame, gear case and cover.
- ✦ Hardened link-type alloy steel load chain for strength and long wear.
- ✦ Free wheeling feature serves to quickly attach the load.
- ✦ Metric rated.



Cable Lever Operated Hoist

- ✦ Capacities — 500 lbs. to 2 tons.
- ✦ Handle design for overload protection - bends to prevent overload.
- ✦ Hooks with safety latches — 360° swiveling hooks equipped with safety latches for positive load engagement.
- ✦ Lightweight and rugged — special cast aluminum alloy housings.
- ✦ Corrosion resistant — all stainless steel springs and shafts.
- ✦ Easy load positioning — utilize a double interlocking pawl system for precise load adjustment.
- ✦ Open construction — allows for easy cleaning and inspection.
- ✦ Self-storage cable drum — provides compact operation.



OTHER QUALITY CM PRODUCTS

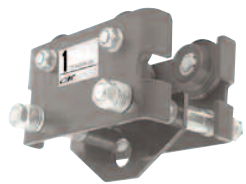

CBTP
(Plain Trolley)
1/4 To 5 Ton



CBTG
(Geared Trolley)
1 To 5 Ton



Plain or Geared Trolleys

- ✦ Capacities - Rated loads from 500 lbs. to 5 tons in plain and geared models.
- ✦ Economical - Excellent low cost choice for manual and powered hoists.
- ✦ Rugged - Designed to provide superior performance and long, efficient service.
- ✦ Low Rolling Effort - Geared models have standard 6 ft. hand chain drop. Other hand chain drops available.
- ✦ Universal Hanging Clevis Accepts most hook mounted hoists.
- ✦ Adjustable - Trolley easily adjusts to fit any beam flange within range of adjustment, up to an 8.7" flange width.
- ✦ Wrap-Around Side Plates - Lugs provide additional security to increase operator safety and act as bumpers to protect wheels.
- ✦ Dual Tread Wheels - Will fit either tapered or flat beam flange within range of adjustment. Wheels include permanently lubricated, shielded ball bearings for long life and low maintenance.
- ✦ Lifetime Warranty.

CM Series 632 Close Radius Trolley

- ✦ Capacities - Rated loads from 500 lbs. to 3 tons.
- ✦ Negotiates radius curves as tight as 7' to 10'.
- ✦ Made of highest quality rolled steel.
- ✦ Unique double row, ball bearing wheel design for greater wear capacity.
- ✦ Larger V-bars available for wider flange adjustment.
- ✦ For low headroom applications.
- ✦ Permanently lubricated bearings.
- ✦ Exclusive Dial-Fit collar quickly adapts trolley to wide range of beams and patented rails.
- ✦ Dust covers shield and protect bearings.
- ✦ Trolleys available for larger beams, rails or tracks; contact CM.
- ✦ Cast iron trolley guards available (except for 3 ton).
- ✦ Lifetime warranty.



Series 633 Wide Range Trolley

- ✦ Capacities — 1/2 to 5 tons.
- ✦ Rugged steel side plates formed to include bumpers and trolley guards for added security.
- ✦ Hardened wheels and axles for added strength and durability.
- ✦ Permanently lubricated bearings.
- ✦ Fits wide range of beam applications.
- ✦ Frames connected by steel equalizer pin, secured by two nuts on each side.



Series 635 Motorized Trolley

- ✦ 250 lbs. thru 3 ton capacities.
- ✦ Speeds 30 F.P.M. - 75 F.P.M.
- ✦ Hardened cast iron wheels with universal design can be used on tapered or flat flanged beams.
- ✦ Rugged steel side plates for added strength and durability.



CM Beam Clamp

- ✦ Suitable for use with powered hoists and chain blocks.
- ✦ Load pin incorporated for load suspension with reduced headroom.
- ✦ Working load limit up to 10 tons.
- ✦ Designed to fit flanges of most structural beams.
- ✦ All CM Screwlok girder clamps are factory proof tested and a certification is shipped with each product.



THEATRICAL SHACKLES

Theatrical Shackles-Black

Dimensions (inches)

Working Load Limit (Tons)	D	P	W	L	B	R
3	1/2	5/8	13/16	1 15/16	1 3/8	1 3/8
3 1/4	5/8	3/4	1 1/16	2 3/8	1 5/8	1 5/8
6 1/2	3/4	7/8	1 1/4	2 7/8	1 3/4	2 1/8

- ~ Screw pin standard, round pin and bolt and nut type also available.
- ~ 100% Proof tested at 2.2 times the working load limit.
- ~ Ultimate strength equals 6 times the working load limit



Anchor Shackles - Screw Pin - Carbon Steel

Dimensions (Inches)

Working Load Limit (Tons)	D	P	W	L	B	R
3	1/2	5/8	13/16	1 15/16	1 3/8	1 3/8
3 1/4	5/8	3/4	1 1/16	2 3/8	1 5/8	1 5/8
6 1/2	3/4	7/8	1 1/4	2 7/8	1 3/4	2 1/8

- ~ Available in diameters from 3/16 to 2
- ~ Available unpainted, Black, or galvanized.

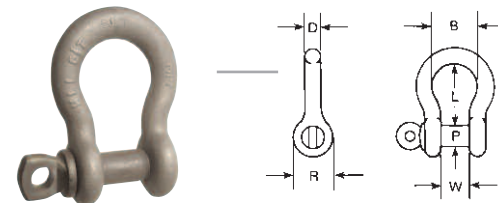

Anchor Shackles - Screw Pin - Alloy Steel

Dimensions (Inches)

Working Load Limit (Tons)	D	P	W	L	B	R
3 1/3	1/2	5/8	13/16	1 15/16	1 3/8	1 3/8
5	5/8	3/4	1 1/16	2 3/8	1 5/8	1 5/8
7	3/4	7/8	1 1/4	2 7/8	1 3/4	2 1/8

- ~ Available in diameters from 3/16 to 2
- ~ Available unpainted, Black, or galvanized.

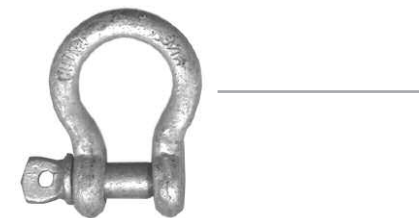

CM STAC Chain - Special Theatrical Alloy Chain (STAC)

Dimensions (Inches)

- 1/2 Diameter
- 3 ft. to 15 ft. lengths available

