



**COLUMBUS MCKINNON CORPORATION
ENTERTAINMENT PRODUCTS DIVISION**

140 John James Audubon Parkway, Amherst, New York 14228
800.888.0985 | 716.689.5400 | Fax 716.689.5619 | www.cm-et.com



METEOR WINCH LINE CATALOG

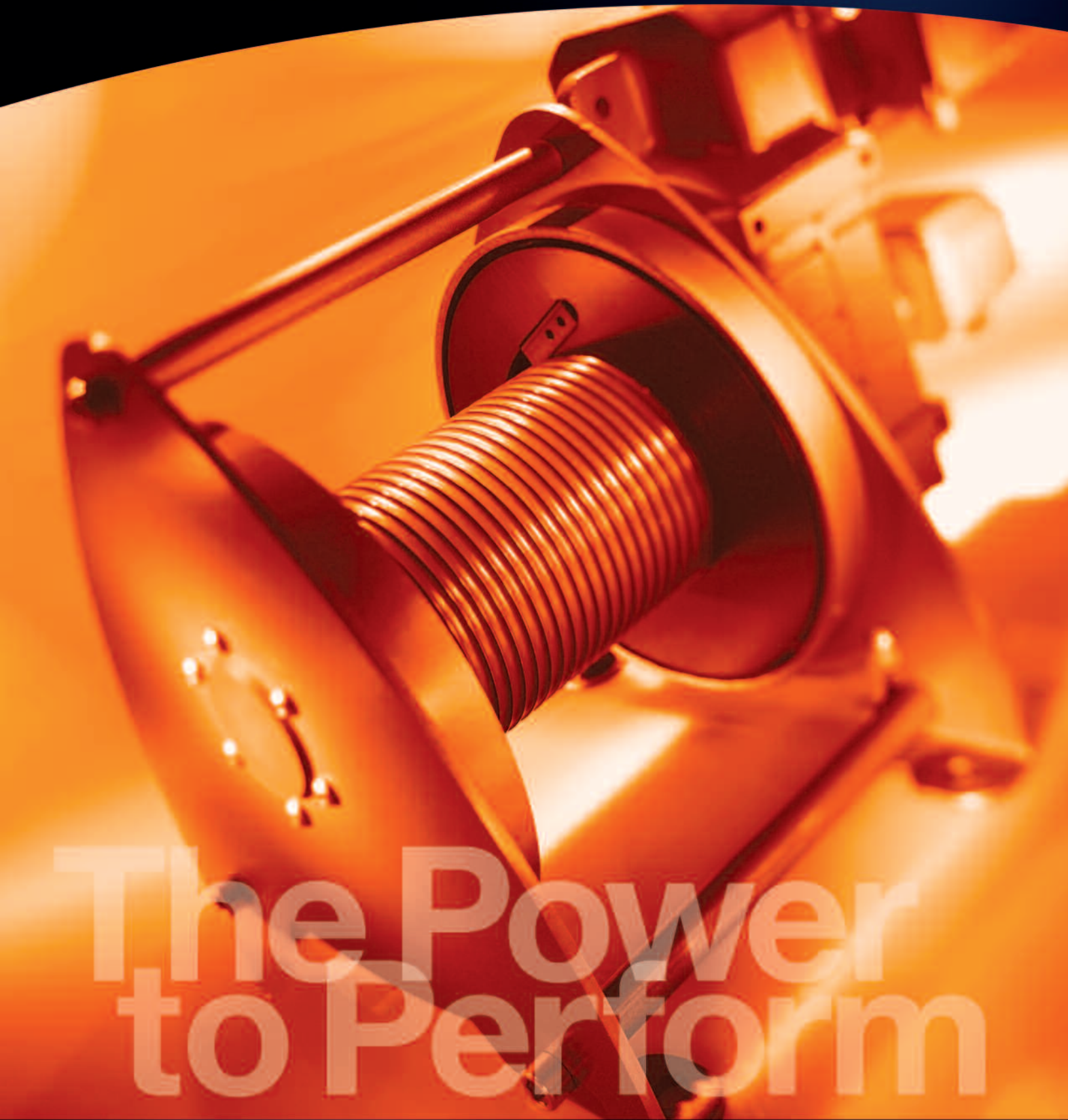

The Power
to Perform

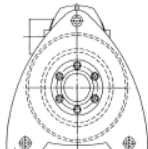
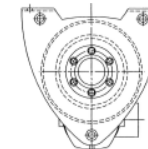
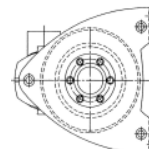
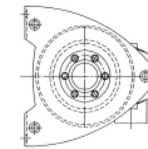
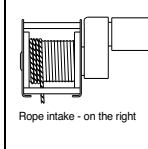
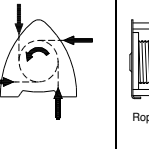
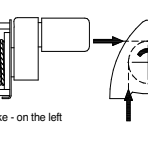

The Power to Perform

<input type="checkbox"/> H 01	<input type="checkbox"/> H 02	<input type="checkbox"/> H 03	<input type="checkbox"/> H 04	<input type="checkbox"/> Rope coiling right	<input type="checkbox"/> Rope coiling left	<input type="checkbox"/>
						
Control System:		Yes <input type="checkbox"/> No <input type="checkbox"/> on customer site				
Standard; according to winch design:		<input type="checkbox"/> integrated in plastic housing with reversing switch and main switch				
Control voltage		<input type="checkbox"/> 42V- 60Hz				
Built-in control elements		<input type="checkbox"/> Basic design				
External hand-actuated auxiliary switch		<input type="checkbox"/> Up/Down/Emergency-Stop				
External Pendant Control		<input type="checkbox"/> Up/Down/Emergency-Stop				
Length of control cable		<input type="checkbox"/> 16.4 ft. (Standard) Special length ft.				
Radio control		<input type="checkbox"/> Range 328 ft.				
Electronic overload protection		<input type="checkbox"/> As standard integrated with a lifting capacity of 1 ton or more				

Accessories:		
Gear limit switch	<input type="checkbox"/> 2 switching contacts <input type="checkbox"/> 4 switching contacts	Way of rope: ft. (4 switching contacts as standard for BGV C1)
Rope pressure drum	<input type="checkbox"/>	
Slack rope switch	<input type="checkbox"/>	
Miscellaneous:		
Wire Rope	<input type="checkbox"/> complete rope length (incl. safety winding on the drum) ft. Type of rope:.....	
Load hook	<input type="checkbox"/>	
Sheave loose	<input type="checkbox"/> pcs. -Art.-No.	
Wire Rope Pulley Block	<input type="checkbox"/> pcs. -Art.-No.	

Enclosures
<input type="checkbox"/> Sketch
<input type="checkbox"/> Layout / Drawing No.
<input type="checkbox"/>

Date: _____ Signature: _____

Additional information:	Price idea of customer:	\$
	Rating of success:%
	Competitor:	

Kind of quotation:

<input type="checkbox"/> Abstracted Quotation	<input type="checkbox"/> Target price	<input type="checkbox"/> Quotation until:
<input type="checkbox"/> Detailed Quotation	<input type="checkbox"/> Requested delivery dateper <input type="checkbox"/> phone <input type="checkbox"/> fax <input type="checkbox"/> mail



COLUMBUS MCKINNON CORPORATION
ENTERTAINMENT PRODUCTS DIVISION
 140 John James Audubon Parkway
 Amherst, New York 14228
 Phone: 716.689.5400 Fax: 716.689.5619

INTRODUCING OUR NEW LINE OF WINCHES



Columbus McKinnon Entertainment Technology, the industry leader in providing reliable lifting and positioning equipment for riggers around the world, presents the Meteor line of manual and powered winches. This latest addition to our broad range of products for arenas, theaters, gymnasiums, and related entertainment and sports venues allows users to smoothly and easily perform rigging functions necessary for a top class event. Complements to the popular Lodestar hoist or “motor,” Meteor winches come in various styles and capacities.

Wall-mounted wire rope winches are ideal for the raising and lowering of banners, nets, and scenery. Additionally, console-mounted wire rope winches provide maximum flexibility when used in theatres and studios. Electric wire rope winches provide superior performance when lifting speeds are vital. Whatever the lifting requirement, there is a Meteor winch for the job.

Products from Columbus McKinnon Entertainment Technology are available through our global network of distributors, so quality products, parts, and service are always close by. Training programs involving proper use and maintenance are also readily available, and our customer service staff is on hand to address specific needs.

When searching for products and services to ensure that your event shines, turn to the company with more than 130 years of experience in exceeding the needs of our customers – Columbus McKinnon.

A complete look at our diverse product offering is available at www.cm-et.com



TABLE OF CONTENT

LB CONSOLE-MOUNTED WIRE ROPE WINCHES	PAGE 2	SW-K CONSOLE-MOUNTED WIRE ROPE WINCHES	PAGE 8
SW-W WALL-MOUNTED WIRE ROPE WINCHES	PAGE 4	HAND WINCH ACCESSORIES	PAGE 9
SW-K CONSOLE-MOUNTED ALUMINUM WIRE ROPE WINCHES	PAGE 6	SW-E STANDARD ELECTRIC WIRE ROPE WINCHES	PAGE 10
SW KAL CONSOLE-MOUNTED ALUMINUM WIRE ROPE WINCHES	PAGE 7	MODEL RPE ELECTRIC WIRE ROPE WINCHES	PAGE 12
		APPLICATION QUESTIONNAIRE	TEAR-OUT

LB CONSOLE-MOUNTED WIRE ROPE WINCHES

SW K-LB WIRE ROPE WINCH GALVANIZED DESIGN

We have designed manual lifting to be not only secure but also ergonomic: The friction disk brake equipped with a shuttle valve on our wire rope winch prevents unintentional lowering of the load in every position. These wire rope winches with tension loads of 330 lbs. up to 2,645 lbs. have been galvanized for maximum protection against corrosion.

GALVANIZED DESIGN

330 to 700 LBS. (shown on right)
1,430 to 1,985 LBS. (shown on left)
2,645 LBS. with automatic uncoil (shown on page 3)



SW K-LB-VA WIRE ROPE WINCH STAINLESS STEEL DESIGN

The robust high-quality LB wire rope winch is made of V2A stainless steel – suitable for outside use.

Whether used for lifting, opening gates, or for lifting and lowering portable staging, this console-mounted hand wire rope winch effortlessly handles the job.

STAINLESS STEEL DESIGN

1,985 LBS. (shown left)
1,433 LBS. (shown middle)
550 LBS. (shown right)



VARIABLE CRANK

FOLDABLE CRANK

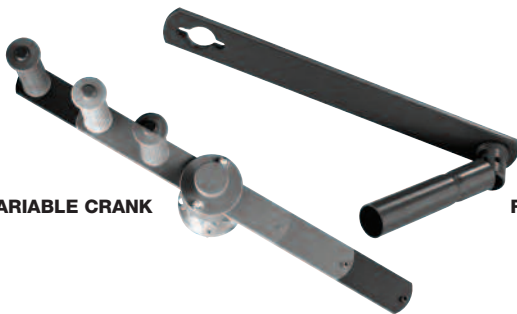

E
N
I
L
L
C
H
I
N
W
I
N
G
R
O
O
T
E
E
M
2



QUESTIONNAIRE WIRE ROPE WINCHES

In order for us to assist you with your application, please complete and return to us via fax or scan and email to sales@cmworks.com

Customer Number
 Company

 Street.....
 ZIP Code.....
 Location/Country.....
 Phone.....
 Fax

Contact Person

Position

Quantity:

Application of winch: (sketch or installation drawing with dimensions)?

Hoisting winch
 Winch for positioning
 Hauling winch/ recovery winch
Environment:
 Outdoor
 roofed
 corrosive medium _____

Duty cycle:
 S3-40% S3-_____%

Operating factor of load alternation/h
 ... Shift operation (e.g. 2 shifts)
 ... Stroke per load alternation

Technical details:		Explanation (additional):
Lifting capacity:lbs	
Rope speed:ft/min	<input type="checkbox"/> Infinitely variable rope speed Ratio of control: <input type="checkbox"/> 1:5, (10-60 Hz) <input type="checkbox"/> 1:9 (10-87 Hz)
Lifting height/ Rope capacity on drumft	
Multilayer winding possible? (Keep in mind the traction force reduction)	<input type="checkbox"/> Yes <input type="checkbox"/> No	
Number of ropes	
Load distribution (at multiple ropes)	
Operation voltage:	<input type="checkbox"/> 3x 230/460 V 60 HzV..... Hz
Motor protection	<input type="checkbox"/> Standard IP 54	<input type="checkbox"/> Type of protection: IP__
Ambient temperature:	<input type="checkbox"/> Standard -4°F up to 104°F

A COMPLETE PRODUCT LINE WITH THE POWER TO PERFORM



Meteor winches are just one important part of the diverse offering from Columbus McKinnon Entertainment Technology (CM-et). For decades, riggers have trusted the black **Lodestar** or “motor” for lifting and positioning of lighting grids, speakers, trusses, and related items needed for a show-stopping performance. From large venues like the Olympics and national conventions to local theater production companies, the Lodestar means unsurpassed reliability with maximum versatility. Featuring a lifetime warranty, the Lodestar’s adjustable limit switch prevents load from over travel. Additionally, its finger-safe wiring configuration with quick-change plugs allow for voltages from 208 through 480. The popular Lodestar fits in standard flight cases for easy transport, and it meets or exceeds world standards.

A number of manual hoisting and positioning tools are also available from CM-et. **Mini-hoists** fit in standard toolboxes and can handle loads weighing up to 1100 lbs. Perfect for tight quarters, these units may be operated using one hand, and feature a Weston style load brake that requires no lubrication.

For easy attachment of rigging products to standard beams, CM-et offers a wide range of clamps and trolleys. **Beam clamps** are suitable for use with powered hoists and chain blocks and can be installed in a matter of minutes. The popular “**V-bar**” **close radius trolley** is ideal for low headroom applications. Integral dust covers shield and protect the units’ permanently lubricated bearings, and the exclusive Dial-Fit collar allows the trolley to be used on a wide range of beams.

A number of **rigging accessories** are readily available including shackles, wire rope clips, shoulder eyebolts, turnbuckles, thimbles, and links. Additionally, Special Theatrical Alloy Chain (STAC) is ideal for use where the ability to adjust the bridle is a must.

In addition to the diverse product offering, **training classes** are conducted by factory representatives and by distributors on a regular basis. These sessions focus on proper maintenance of hoists, best practices in lifting, and troubleshooting techniques for use onsite.

To satisfy all of your lifting needs in the entertainment market, rely on the company with a rich 130-year heritage – Columbus McKinnon. For additional details, visit www.cm-et.com or call us at 716.689.5400



E
N
T
E
R
T
A
I
N
M
E
N
T

LB CONSOLE-MOUNTED WIRE ROPE WINCHES



LB 2,645 LBS.
WITH AUTOMATIC UNCOIL
(for manual pulling-off the unloaded wire rope)

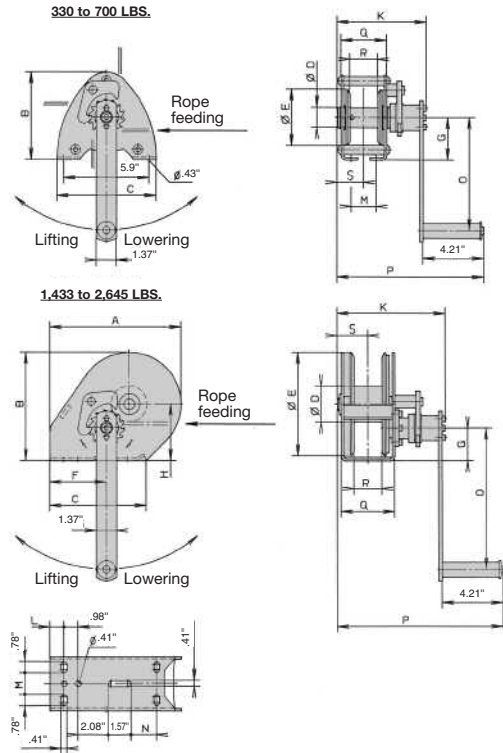

Model No.		030239016V	030239015V	040239004V	040239006V	040239008V	-	-	-
Galvanized design									
Automatic uncoil		-	-	-	040239007V	040239009V	-	-	-
Stainless steel design		-	-	-	-	-	030239017V	040239012V	030239013V
Lifting capacity - 1st rope layer	lbs	330	700	1433	1985	2645	550	1433	1985
Lifting capacity - upper rope layer	lbs	165	375	640	880	948	275	640	705
Drive group DIN 15020	1 Em	1 Em	1 Em	1 Em	1 Em	1 Em	1 Em	1 Em	
Wire rope diameter	mm	4*	4*	6*	7*	7**	4*	6*	7*
Wire rope capacity - 1st layer	ft	2 ft, 7 in	5 ft, 11 in	3 ft, 3 in	2 ft, 7 in	3 ft, 3 in	5 ft, 11 in	3 ft, 3 in	3 ft, 3 in
Wire rope capacity - total	ft	36 ft, 1 in	65 ft, 7 in	65 ft, 7 in	45 ft, 11 in	85 ft, 4 in	64 ft	65 ft, 7 in	85 ft, 4 in
Lift per crank rotation	in	4 15/16	4 15/16	2 3/16	2 5/16	1 3/4	4 15/16	2 3/16	1 3/4
Required crank pressure	lbf	38.2	56.2	49.5	54.0	54.0	45.0	49.5	54.0
Weight	lbs	9.25	10.6	16.1	22	26.7	10.6	16.75	26.7
A	in	-	-	9 1/8	9 1/8	10 3/4	-	9 1/8	10 3/4
B	in	6 1/8	6 1/8	7 9/16	7 9/16	10 1/2	6 1/8	7 9/16	10 1/2
C	in	6 7/8	6 7/8	8 1/4	8 1/4	9 7/16	6 7/8	8 1/4	9 7/16
Ø D	in	1 7/16	1 7/16	2 1/2	2 1/2	2 1/2	1 7/16	2 1/2	2 1/2
Ø E	in	3 15/16	3 15/16	7 3/16	7 3/16	10 1/16	3 15/16	7 3/16	10 1/16
F	in	-	-	3 15/16	3 15/16	3 1/16	-	3 15/16	3 1/16
G	in	2 15/16	2 15/16	2 5/16	2 5/16	2 15/16	2 15/16	2 5/16	2 15/16
H	in	-	-	3 15/16	3 15/16	5 7/16	-	3 15/16	5 7/16
K	in	6 1/4	7 7/16	7 9/16	7 9/16, 8 7/8***	7 9/16, 8 7/8***	7 9/16	7 1/2	7 1/2
L	in	-	-	1	1	1 3/8	-	1	1 3/8
M	in	1 3/4	2 15/16	1 1/2	1 1/2	1 3/16	2 15/16	1 1/2	1 3/16
N	in	-	-	-	-	2 1/16	-	-	2 1/16
O	in	7 1/4	12 5/8	9 13/16	12 5/8	12 5/8	12 5/8	9 13/16	9 13/16
P	in	10 1/4	11 7/16	11 9/16	11 9/16, 11 15/16***	11 9/16, 11 15/16***	11 1/2	11 7/16	11 7/16
R	in	1 15/16	3 1/8	1 15/16	1 15/16	1 15/16	3 1/8	1 15/16	1 15/16
Q	in	3 3/16	4 3/4	3 3/4	3 3/4	3 3/4	4 3/8	3 3/4	3 3/4
S	in	1 7/8	2 1/2	2 3/16	2 3/16	2 3/16	2 9/16	2 3/16	2 9/16

* recommended wire rope: DIN 3060 FE-znk 1770 sZ-spa ** recommended wire rope: DIN 3060 SE-znk 2160 sZ-spa *** automatic uncoil lbf = lb. force

SW-W WALL-MOUNTED WIRE ROPE WINCHES

SW-W WALL-MOUNTED WIRE ROPE WINCH

Good ideas make life easier: Our wall-mounted wire rope winches in 176 and 275 lb. capacities are supplied with a removable crank, inside braked spring retention, and aluminum housing. Workers in gymnasiums, auditoriums, aquatic centers and arenas will find the SW winch the perfect equipment for most requirements, as they are robust and superbly engineered. For a tensile load of 600 lbs. or more, CM offers winches with spur-gearing, an externally mounted safety spring-loaded crank and steel panel housing. Special safety lock-out with removable hand crank is also available.



SW-W WALL-MOUNTED
176 to 275 LBS. (shown top)
660 to 1,653 LBS. (shown right)

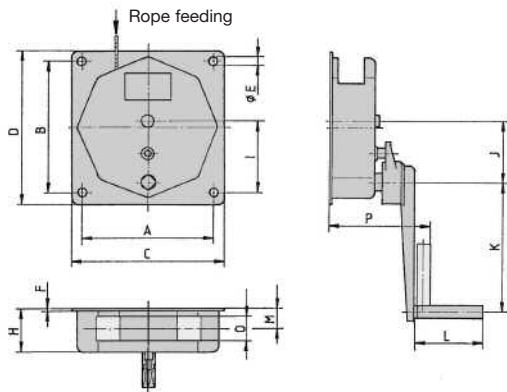

Model No.			040271017V	040271008V	030271001V	030271136V	030271019V
Lifting capacity	1st layer	lbs	176	275	660	1102	1653
	Upper layer	lbs	100	143	485	770	1212
Drive Group	DIN 15020		1Em	1Em	1Em	1Em	1Em
Drum diameter	N	in	2	1 ⁹ / ₁₆	4 ¹ / ₄	4 ¹ / ₄	4 ¹ / ₄
Drum length		in	2 ³ / ₈	2 ³ / ₈	1 ¹⁵ / ₁₆	1 ¹⁵ / ₁₆	1 ¹⁵ / ₁₆
Wire rope diameter		mm	3*	4*	5**	6**	7**
Wire rope capacity	1st layer	ft	7 ft., 10 in.	6 ft., 7 in.	6 ft., 11 in.	7 ft., 10 in.	6 ft., 7 in.
	Upper layer	ft	98 ft., 5 in.	39 ft., 4 in.	49 ft., 3 in.	49 ft., 3 in.	32 ft., 10 in.
Lift per crank rotation		in	6 ¹¹ / ₁₆	5 ⁷ / ₁₆	2 ¹¹ / ₁₆	1 ³ / ₈	1 ³ / ₈
Required crank pressure		lbf	26.98	29.23	33.72	29.23	44.96
Weight		lbs	6.6	6.6	22.0	24.3	24.3
A		in	4 ⁵ / ₁₆	4 ⁵ / ₁₆	9 ¹³ / ₁₆	9 ¹³ / ₁₆	9 ¹³ / ₁₆
B		in	4 ⁵ / ₁₆	4 ⁵ / ₁₆	9 ¹³ / ₁₆	9 ¹³ / ₁₆	9 ¹³ / ₁₆
C		in	5 ¹ / ₈	5 ¹ / ₈	11 ⁷ / ₁₆	11 ⁷ / ₁₆	11 ⁷ / ₁₆
D		in	5 ¹ / ₈	5 ¹ / ₈	11 ⁷ / ₁₆	11 ⁷ / ₁₆	11 ⁷ / ₁₆
Ø E		in	3 ⁸ / ₁₆	3 ⁸ / ₁₆	9 ¹ / ₁₆	9 ¹ / ₁₆	9 ¹ / ₁₆
F		in	3 ⁴ / ₁₆	9 ¹ / ₁₆	1 ¹ / ₁₆	1 ¹ / ₁₆	1 ¹ / ₁₆
H		in	4 ³ / ₄	4 ³ / ₄	3 ³ / ₈	3 ³ / ₈	3 ³ / ₈
I		in	2 ³ / ₁₆	2 ³ / ₁₆	5 ⁷ / ₁₆	5 ⁷ / ₁₆	5 ⁷ / ₁₆
J		in	-	-	4 ⁵ / ₈	4 ⁵ / ₈	4 ⁵ / ₈
K		in	9 ¹³ / ₁₆	9 ¹³ / ₁₆	9 ¹³ / ₁₆	9 ¹³ / ₁₆	9 ¹³ / ₁₆
L		in	5 ¹ / ₈	5 ¹ / ₈	5 ¹ / ₈	5 ¹ / ₈	5 ¹ / ₈
M		in	2 ¹¹ / ₁₆	2 ¹¹ / ₁₆	1 ⁹ / ₁₆	1 ⁹ / ₁₆	1 ⁹ / ₁₆
O		in	2 ³ / ₈	2 ³ / ₈	1 ¹⁵ / ₁₆	1 ¹⁵ / ₁₆	1 ¹⁵ / ₁₆
P		in	10 ¹³ / ₁₆	10 ¹³ / ₁₆	7 ⁹ / ₁₆	7 ⁹ / ₁₆	7 ⁹ / ₁₆

* recommended wire rope: DIN 3055 FE-znK 1770 sZ-spa

** recommended wire rope: DIN 3060 FE-znk 1770 sZ-spa

lbf = lb. force

MODEL RPE ELECTRIC WIRE ROPE WINCH



MODEL RPE

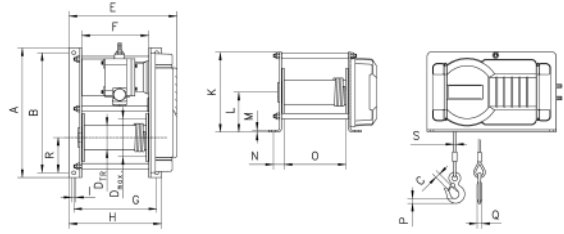

Rope lead-offs for electric rope winch RPE

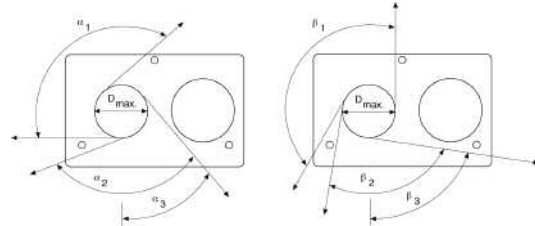

Technical Data Model RPE

Model	EAN-No. 4025092*	Pulling force*	Lifting speed*	Rope diameter	Motor	ED at 120 c/h	Useable rope length in the 1st layer ft	Useable rope length in the 2nd layer ft	Useable rope length in the 3rd layer ft	Useable rope length in the 4th layer ft	Weight without rope
		lbf	ft/min	mm	hp	%					lbs
RPE 2-13B	*071796	562.02	47.6	4	0.737	40	36' 9"	80' 1"	127' 4"	178' 10"	70
RPE 5-6B	*071857	1124.04	23.8	6	0.737	40	23'	53' 10"	88' 7"	127' 4"	72
RPE 5-12B	*071918	1124.04	43.9	6	1.474	40	36' 1"	81' 8"	130' 3"	181' 9"	90
RPE 9-6B	*071956	2225.61	22.0	8	1.474	40	33' 6"	75' 6"	122' 8"	-	168
RPE 10-6B**	*072014	2248.09	22.0	8	1.474	40	33' 6"	75' 6"	122' 8"	-	170

lbf = lb. force * In the top rope layer ** With slip clutch

Grooved Drum (recommended for single layer operation)

Model	Pulling force in top layer lbf	Drum Size	Rope length 1st layer ft	Max rope length ft
RPE 2-13 RB	562.02	1	28 ft., 10 in.	141 ft., 1 in.
RPE 5-6 RB	1124.04	1	20 ft., 4 in.	108 ft., 3 in.
RPE 9-6/10-6 RB	2225.61 / 2248.09	1	26 ft., 11 in.	98 ft., 5 in.
RPE 2-13 LRB	562.02	2	43 ft., 8 in.	210 ft.
RPE 5-6 LRB	1124.04	2	31 ft., 2 in.	160 ft., 9 in.
RPE 5-12 LRB	1124.04	2	31 ft., 2 in.	160 ft., 9 in.
RPE 9-6/10-6 LRB	2225.61 / 2248.09	2	42 ft., 4 in.	154 ft., 2 in.
RPE 2-13 XLRB	562.02	3	115 ft., 10 in.	541 ft., 4 in.
RPE 5-6 XLRB	1124.04	3	84 ft., 4 in.	419 ft., 11 in.
RPE 5-12 XLRB	1124.04	3	84 ft., 4 in.	419 ft., 11 in.
RPE 9-6/10-6 XLRB	2225.6 / 2248.09	3	82 ft., 8 in.	292 ft.

Plain Drum (longer useable rope length)

Model	Pulling force in top layer lbf	Drum Size	Max rope length ft
RPE 2-13 LB	562.02	2	262 ft., 6 in.
RPE 5-6 LB	1124.04	2	190 ft., 3 in.
RPE 9-6/10-6 LB	2225.61 / 2248.09	2	183 ft., 9 in.
RPE 2-13 XLB	562.02	3	656 ft., 2 in.
RPE 5-6 XLB	1124.04	3	459 ft., 4 in.
RPE 5-12 XLB	1124.04	3	459 ft., 4 in.
RPE 9-6/10-6 XLB	2225.61 / 2248.09	3	328 ft., 1 in.

lbf = lb. force

Dimensions Model RPE

Model	RPE 2-13B	RPE 5-6B	RPE 5-12B	RPE 9-6B	RPE 10-6B
A, in	15 15/16	15 15/16	15 15/16	20 11/16	20 11/16
B, in	14 3/4	14 3/4	14 3/4	19 1/8	19 1/8
C, in	1 1/16	1 1/16	1 1/16	1	1
DTR, in	3	3	3	4 1/4	4 1/4
Dmax, in	4 1/8	4 5/8	4 5/8	5 13/16	5 13/16
A, in	5 7/8	5 7/8	5 7/8	7 1/16	7 1/16
E, in	13 1/4	13 1/4	16 3/4	18 5/16	18 5/16
F, in	8 1/4	8 1/4	11 13/16	10 5/8	10 5/8
G, in	10 1/4	10 1/4	13 3/4	13 3/16	13 9/16
H, in	11 7/16	11 7/16	14 15/16	14 15/16	14 15/16
I, in	7/16	7/16	7/16	1/2	1/2
K, in	9 13/16	9 13/16	9 13/16	13 3/8	13 3/8
L, in	4 15/16	4 15/16	4 15/16	6 11/16	6 11/16
M, in	1/4	1/4	1/4	9/16	9/16
N, in	1 3/16	1 3/16	1 3/16	1 7/8	1 7/8
O, in	7 5/8	7 5/8	11 3/16	9 13/16	9 13/16
P, in	3/4	3/4	3/4	15/16	15/16
Q, in	1/2	1/2	1/2	3/4	3/4
R, in	4 15/16	4 15/16	4 15/16	6 11/16	6 11/16
S, in	3/16	1/4	1/4	5/16	5/16
β 1, °	130	130	130	145	145
β 2, °	110	110	110	125	125
β 3, °	40	40	40	50	50
β 1, °	150	150	150	155	155
β 2, °	90	90	90	100	100
β 3, °	80	80	80	83	83

MODEL RPE ELECTRIC WIRE ROPE WINCH

MODEL RPE ELECTRIC WIRE ROPE WINCH

RPE winches are designed explicitly for performance, efficiency, and security, and offer many advantages and options. The unit's extremely compact, practical cube design and universal rope lead-offs allow individual applications in almost any position and make these winches powerful aids for lifting and pulling loads.

The winches are designed to DIN 15020, classification 1 Bm, safety regulation BGV D8 (winch, lift and pull equipment) and the EC machinery directives.

Features

- Compact dimensions due to internal brake motor.
- Standard: Euro-voltage 400 V/230 V, 3-phase, 50 Hz, protected to IP 54, insulation class F.
- Adjustable slip clutch to protect the winch from overloading standard for Model RPE 10-6.
- Spur gear transmission with helical first gear ensures smooth motion. Lubricated by grease and can, therefore, be used in any position.
- Plain rope drum standard.
- Spring pressure disc brake incorporated in the motor holds the load secure even in the event of a power failure.
- The rope is secured to the drum in a recess so that the rope can be wound onto the drum in several layers without damage.
- The standard version comes with direct control.
- Integrated emergency stop.

Options

- Different drum designs, e.g. extended to accommodate longer rope, machined grooves for exact reeling, with separation web and second rope outlet for working with two ropes.
- Geared limit switches to limit rope motion in both directions.
- Single-phase A.C. motor 230 V, 50 Hz, for mobile application of the winch. Control by means of pendant control including control switch with emergency stop and 2 m long control cable.
- Contactor control with 42V control voltage.
- Slack rope switch to automatically stop the winch when rope tension eases e.g. when the load touches down (only in combination with low voltage control).
- Frequency converter for stepless speed control.
- Adjustable slip clutch to protect the winch from overloading for models RPE 2-13, RPE 5-6 and RPE 5-12.
- Special design according to BGV C1 for theater stage applications available.



SW-W WALL-MOUNTED WIRE ROPE WINCHES

SW-W WALL-MOUNTED WIRE ROPE WINCH

The versatile SW-W wall-mounted wire rope winch is extremely smooth in every application. Equipped with a toothed spur wheel back gear, the low net weight and compact design allows this winch to meet an abundance of requirements. Easily mounts onto the wall and permits rope output in any direction.

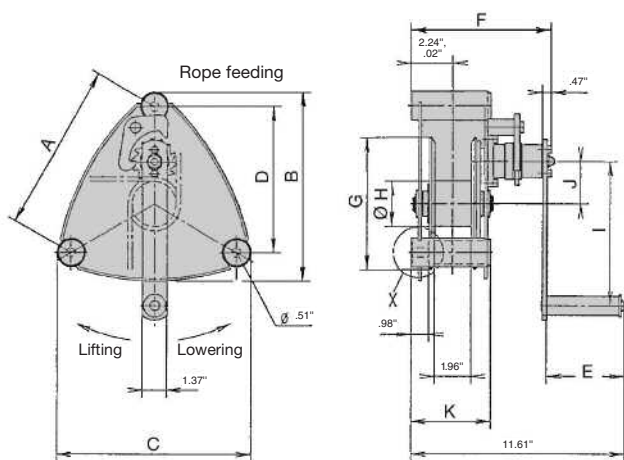
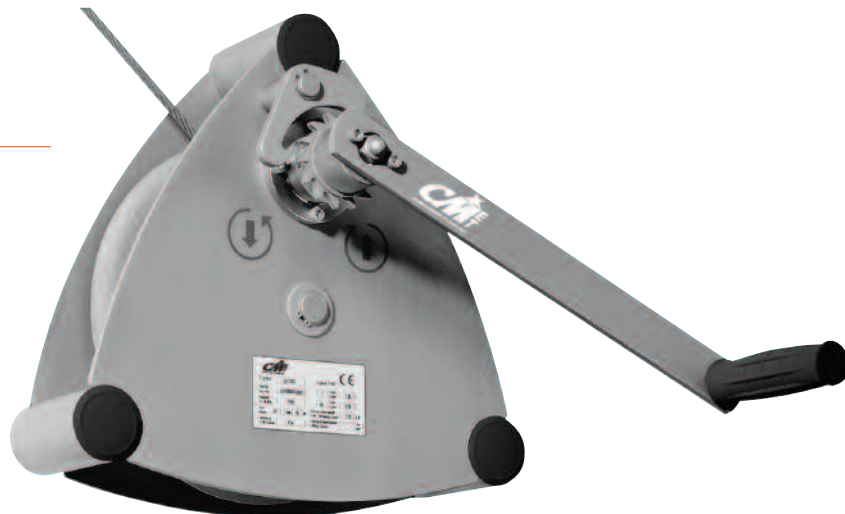

FOLDABLE CRANK
VARIABLE CRANK

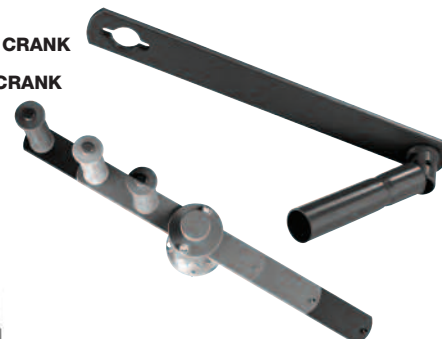

Model No.			030272006V	030272005V	030272002V	030272001V
Lifting capacity	1st layer	lbs	660	1102	1653	2204
	upper layer	lbs	286	507	595	793
Drive group DIN 15020			1Em	1Em	1Em	1Em
Drum diameter		in	2 1/2	2 1/2	2 1/2	2 1/2
Drum width		in	1 15/16	1 15/16	1 15/16	1 15/16
Wire rope diameter*		mm	5	6	7	7
Wire rope capacity	1st layer	ft	4 ft., 3 in.	3 ft., 3 in.	3 ft., 3 in.	3 ft., 3 in.
	upper layer	ft	91 ft., 10 in.	65 ft., 7 in.	85 ft., 4 in.	85 ft., 4 in.
Lift per crank rotation		in	2 1/4	2 3/16	1 3/4	1 3/4
Required crank pressure		lbf	29.23	38.22	38.22	40.47
Weight		lbs	22.0	22.0	35.3	35.3
A		in	9 9/16	9 9/16	12 1/16	12 1/16
B		in	10 5/16	10 5/16	13 1/4	13 1/4
C		in	10 13/16	10 13/16	14 1/16	14 1/16
D		in	8	8	10 7/16	10 7/16
E		in	4 3/16	4 3/16	4 3/16	4 3/16
F		in	7 5/8	7 5/8	7 5/8	7 5/8
G		in	7 3/16	7 3/16	10 1/16	10 1/16
Ø H		in	2 1/2	2 1/2	2 1/2	2 1/2
I		in	7 7/8	9 13/16	9 13/16	12 5/8
J		in	2 5/16	2 5/16	3 5/8	3 5/8
K		in	4 5/16	4 5/16	4 3/16	4 3/16

* recommended wire rope: DIN 3060 FE-znK 1770 sZ-spa lbf = lb. force

SW-K CONSOLE-MOUNTED ALUMINUM WIRE ROPE WINCHES

SW-K CONSOLE-MOUNTED ALUMINUM WIRE ROPE WINCH

The SW-K wire rope winch is a drum winch equipped with closed sprocket wheel drive and made of aluminum, making it especially suitable for outdoor application. Winches with tension load of 1,102 lbs and more are equipped with an additional speed increasing ratio for winding and unwinding the unloaded rope. The winch allows mounting in every position, can comfortably be operated from either end of the winch, and is equipped with a removable crank. The spring retention is located inside and is therefore maintenance free. As an option for 1,764 lb. winches, a drum separation plate for double rope operation is available.



1,764 LB.

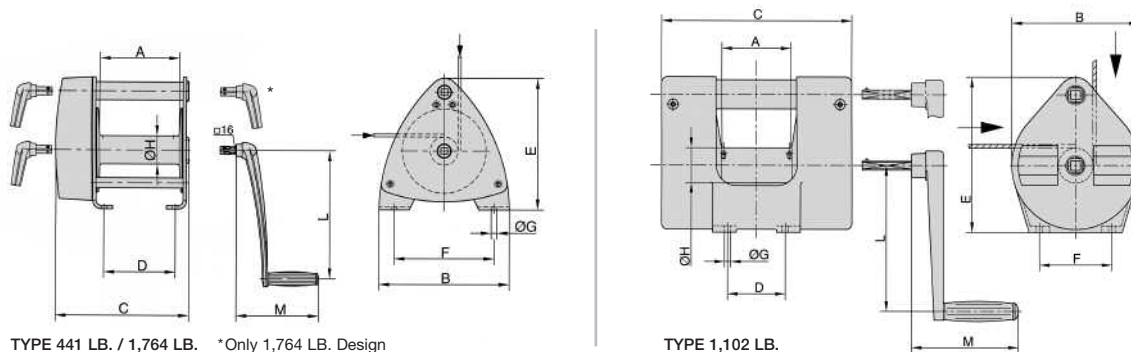

TYPE 441 LB. / 1,764 LB. *Only 1,764 LB. Design

TYPE 1,102 LB.

Model No.			040270004V	040270001V	040270006V
Lifting capacity	1st layer	lbs	441	1102	1764
	upper layer	lbs	243	441	772
Wire rope capacity	1st layer	ft	11 ft., 10 in.	13 ft., 9 in.	17 ft., 5 in.
	upper layer	ft	131 ft., 3 in.	164 ft., 1 in.	255 ft., 11 in.
Drive group	DIN 15020/1		1 Em	1 Em	1 Em
Wire rope diameter*		mm	4	6	7
Lift per crank rotation		in	7 1/16	2 3/8, 15 3/4**	1 7/16, 11**
Required crank pressure		lbf	42.71	26.98	40.47
Ratio of transmission			-	6,57:1	7,57:1
Weight		lbs	13	31	35
A		in	4 3/4	4 3/4	7 7/8
B		in	6 9/16	8 1/16	12 13/16
C		in	7 9/16	13	13 1/4
D		in	6	3 15/16	7 1/16
E		in	6 1/2	10 1/2	12 7/8
F		in	5 5/16	4 15/16	9 13/16
Ø G		in	3/8	7/16	9/16
Ø H		in	1 15/16	2 3/8	2 3/4
L		in	12 3/8	9 13/16	12 5/8
M		in	8 1/8	6 1/8	8 1/8



441 LB.



1,102 LB.

* recommended wire rope DIN 3060 FE-znK-1770 sZ spa ** load /high-speed lbf = lb. force

SW-E ELECTRIC WIRE ROPE WINCHES

SW-E STANDARD ELECTRIC WIRE ROPE WINCH

The SW-E winches are subdivided into 5 sizes (Size 1-5). Due to combination of motor capacity and gear transmission, tension loads of 220 lbs. up to 8.25 ton at rope speeds up to 98.4 ft./min can be supplied from the building block system. All winches can be delivered with numerous options, including A.C. motors.

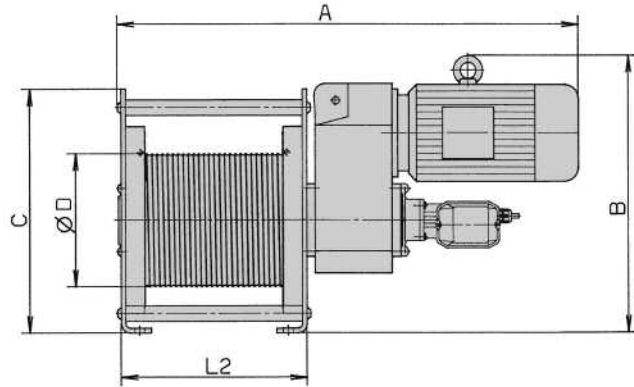

Model No.	Size	Lifting capacity 1 st layer lbs	Drive group FEM	Rope speed 1 st layer ft/min	Motor Power hp	Recomm. Rope Nom. strength lbs/in ²	Rec. Rope diameter* mm	Rope capacity		Weight lbs	Dimensions in inches				
								1 st layer ft	total ft		A	B	C	ØD	L2
031148012V	1	551	2m	34.8	0.56	256,717	5	53' 2"	255' 3"	136	27 ³ / ₁₆	13 ¹ / ₈	12 ¹³ / ₁₆	6 ⁷ / ₈	10 ³ / ₈
031148018V	1	551	2m	50.5	0.80	256,717	5	53' 2"	255' 3"	139	28 ³ / ₁₆	13 ¹ / ₈	12 ¹³ / ₁₆	6 ⁷ / ₈	10 ³ / ₈
031148024V	1	551	2m	77.2	1.25	256,717	5	53' 2"	255' 3"	141	28 ³ / ₁₆	13 ¹ / ₈	12 ¹³ / ₁₆	6 ⁷ / ₈	10 ³ / ₈
031148007V	1	705	2m	20.5	0.43	284,274	5	53' 2"	255' 3"	138	27 ¹⁵ / ₁₆	13 ¹ / ₈	12 ¹³ / ₁₆	6 ⁷ / ₈	10 ³ / ₈
031148013V	1	705	2m	35.1	0.72	284,274	5	53' 2"	255' 3"	139	28 ³ / ₁₆	13 ¹ / ₂	12 ¹³ / ₁₆	6 ⁷ / ₈	10 ³ / ₈
031148019V	1	705	2m	50.5	1.03	284,274	5	53' 2"	255' 3"	141	28 ³ / ₁₆	13 ¹ / ₂	12 ¹³ / ₁₆	6 ⁷ / ₈	10 ³ / ₈
031148025V	1	705	2m	78.0	1.59	284,274	5	53' 2"	255' 3"	148	30 ¹¹ / ₁₆	13 ³ / ₈	12 ¹³ / ₁₆	6 ⁷ / ₈	10 ³ / ₈
031148077V	1	1102	1 Am	31.1	1.01	284,274	6	27' 7"	191' 11"	141	28 ³ / ₁₆	13 ¹ / ₂	12 ¹³ / ₁₆	4 ¹ / ₄	10 ³ / ₈
031148208V	2	1102	2m	37.7	1.22	256,717	8	56' 1"	280' 6"	229	35 ¹¹ / ₁₆	19 ⁹ / ₁₆	17 ¹ / ₂	9 ¹ / ₂	13 ⁵ / ₁₆
031148209V	2	1389	2m	37.7	1.53	256,717	8	56' 1"	280' 6"	229	35 ¹¹ / ₁₆	19 ⁹ / ₁₆	17 ¹ / ₂	9 ¹ / ₂	13 ³ / ₁₆
031148219V	2	1389	2m	74.3	3.02	256,717	8	56' 1"	280' 6"	244	37	19 ⁹ / ₁₆	17 ¹ / ₂	9 ¹ / ₂	13 ³ / ₁₆
031148205V	2	1764	2m	17.6	0.90	284,274	8	56' 1"	280' 6"	222	33 ⁹ / ₁₆	19 ⁹ / ₁₆	17 ¹ / ₂	9 ¹ / ₂	13 ⁵ / ₁₆
031148210V	2	1764	2m	37.7	1.94	284,274	8	56' 1"	280' 6"	229	35 ¹¹ / ₁₆	19 ⁹ / ₁₆	17 ¹ / ₂	9 ¹ / ₂	13 ³ / ₁₆
031148220V	2	1764	2m	75.0	3.85	284,274	8	56' 1"	280' 6"	250	37	19 ⁹ / ₁₆	17 ¹ / ₂	9 ¹ / ₂	13 ³ / ₁₆
031148259V	2	2161	1 Am	27.5	1.72	284,274	9	36' 1"	253' 11"	229	35 ¹¹ / ₁₆	19 ⁹ / ₁₆	17 ¹ / ₂	6 ⁷ / ₈	13 ⁵ / ₁₆
031148403V	3	2756	2m	19.0	1.54	256,717	12	53' 6"	201' 1"	363	39 ¹⁵ / ₁₆	24 ³ / ₁₆	21 ⁹ / ₁₆	11 ⁵ / ₈	16
031148406V	3	2756	2m	40.3	3.23	256,717	12	53' 6"	201' 1"	384	41 ¹⁵ / ₁₆	24 ³ / ₁₆	21 ⁹ / ₁₆	11 ⁵ / ₈	16
031148441V	3	3527	1 Am	29.6	3.06	284,274	12	39' 8"	287' 9"	384	41 ¹⁵ / ₁₆	24 ³ / ₁₆	21 ⁹ / ₁₆	8 ⁹ / ₁₆	16
031148444V	3	3527	1 Am	45.8	4.69	284,274	12	39' 8"	287' 9"	381	40 ¹³ / ₁₆	24 ³ / ₁₆	21 ⁹ / ₁₆	8 ⁹ / ₁₆	16
031148504V	3,5	4409	2m	27.8	3.56	256,717	14	45' 3"	176' 10"	487	42 ¹⁵ / ₁₆	26 ¹⁵ / ₁₆	21 ⁹ / ₁₆	11 ⁵ / ₈	16
031148507V	3,5	4409	2m	40.6	5.21	256,717	14	45' 3"	176' 10"	515	45 ³ / ₁₆	26 ¹⁵ / ₁₆	21 ⁹ / ₁₆	11 ⁵ / ₈	16
031148510V	3,5	4409	2m	59.7	7.66	256,717	14	45' 3"	176' 10"	543	49 ⁹ / ₁₆	26 ¹⁵ / ₁₆	21 ⁹ / ₁₆	11 ⁵ / ₈	16
031148505V	3,5	5512	2m	27.8	4.49	256,717	14	45' 3"	176' 10"	494	42 ¹⁵ / ₁₆	26 ¹⁵ / ₁₆	21 ⁹ / ₁₆	11 ⁵ / ₈	16
031148502V	3,5	5512	2m	20.1	3.22	256,717	14	45' 3"	176' 10"	487	42 ¹⁵ / ₁₆	26 ¹⁵ / ₁₆	21 ⁹ / ₁₆	11 ⁵ / ₈	16
031148511V	3,5	5512	2m	59.7	9.58	256,717	14	45' 3"	176' 10"	543	49 ⁹ / ₁₆	26 ¹⁵ / ₁₆	21 ⁹ / ₁₆	11 ⁵ / ₈	16
031148530V	3,5	7055	1 Am	16.5	3.38	313,282	14	37' 5"	211' 7"	487	42 ¹⁵ / ₁₆	26 ¹⁵ / ₁₆	21 ⁹ / ₁₆	9 ¹ / ₂	16
031148536V	3,5	7055	1 Am	33.3	6.83	313,282	14	37' 5"	211' 7"	515	45 ³ / ₁₆	26 ¹⁵ / ₁₆	21 ⁹ / ₁₆	9 ¹ / ₂	16
031148620V	4	7055	2m	79.4	16.33	256,717	18	51' 2"	203' 5"	1108	55 ⁷ / ₁₆	32 ¹ / ₂	27 ¹ / ₁₆	14 ⁵ / ₁₆	18 ⁷ / ₈
031148644V	4	8818	1 Am	22.7	5.87	284,274	18	41' 8"	322' 6"	958	49 ¹³ / ₁₆	32 ¹ / ₂	27 ¹ / ₁₆	11 ⁵ / ₈	18 ⁷ / ₈
031148652V	4	8818	1 Am	41.0	10.52	284,274	18	41' 8"	322' 6"	1033	54 ¹ / ₈	32 ¹ / ₂	27 ¹ / ₁₆	11 ⁵ / ₈	18 ⁷ / ₈
031148802V	5	11023	2m	15.4	4.90	284,274	20	66' 7"	259' 10"	2309	61	41 ⁹ / ₁₆	33 ³ / ₄	17 ³ / ₄	22 ² / ₈
031148804V	5	11023	2m	31.5	10.16	284,274	20	66' 7"	259' 10"	2247	61	41 ⁹ / ₁₆	33 ³ / ₄	17 ¹ / ₂	22 ² / ₈
031148823V	5	13889	1 Am	12.4	4.98	313,282	20	53' 10"	306' 5"	2309	61	41 ⁹ / ₁₆	33 ³ / ₄	14 ⁵ / ₁₆	22 ² / ₈
031148825V	5	13889	1 Am	25.6	10.33	313,282	20	53' 10"	306' 5"	2247	61	41 ⁹ / ₁₆	33 ³ / ₄	14 ⁵ / ₁₆	22 ² / ₈
031148840V	5	16535	1 Bm	20.9	9.97	313,282	20	44'	343' 10"	2247	61	41 ⁹ / ₁₆	33 ³ / ₄	11 ⁵ / ₈	22 ² / ₈
031148842V	5	16535	1 Bm	37.3	18.04	313,282	20	44'	343' 10"	2420	63 ¹¹ / ₁₆	41 ⁹ / ₁₆	33 ³ / ₄	11 ⁵ / ₈	22 ² / ₈

* recommended steel rope DIN 3069 SE-znk-1960, non-rotating

M E T E O R W I N C H L I N E

SW-E ELECTRIC WIRE ROPE WINCHES



E
L
I
N
E
C
H
I
N
G
W
I
N
C
H
E
R
O
F
E
T
M
E
E

CM offers a diverse range of electric wire rope winches for lifting, lowering, pulling, and positioning loads to meet your specific needs. These winches stand out due to their first-class quality, reliable and durable drive motors. The gearwheels of the maintenance-free spur gear run in an oil-bath. The spiral gearing of the gear wheel guarantees very smooth running. The strong three-phase motors allow running with flexible supply voltage from 380 up to 420 V/50 Hz. or 440 up to 460 V/60 Hz. - motor protection class IP 54. Proper winch operation is ensured by a separated contactor control (42 V/50 Hz.) with integrated "Up-Down/Emergency Stop" buttons as well as the master

switch. Winches with a lifting capacity of 2,200 lbs. have electronic overload protection as standard. CM electric wire rope winches have been developed for diverse applications within the entertainment industry and are designed for a service-life of 400 (1Bm), 800 (1Am) up to 1600 (2m) operating hours when fully loaded. All winches can be operated within temperature ranges of -4°F up to 104°F without special oil filling. Our wire rope winches are equipped with grooved drums with each one wire fastening at the flanged wheels. Upon request, we can deliver drums with special grooves and several wires for special applications.

SW KAL CONSOLE-MOUNTED ALUMINUM WIRE ROPE WINCHES

SW KAL COMPACT CONSOLE-MOUNTED ALUMINUM WIRE ROPE WINCH

The aluminum compact wire rope winch has a closed construction and therefore requires little maintenance. With 1,653 to 2,469 lb. tension loads, it is the perfect partner for superstructures on vehicles and trailers and when lifting and lowering a wide variety of loads. Unit contains many of the convenient features that workers have come to expect from CM, including the self-locking worm gear (at standstill), compact design, and low-friction shaft gearing.

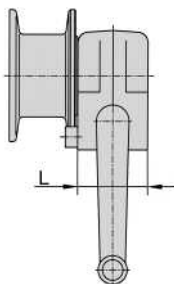
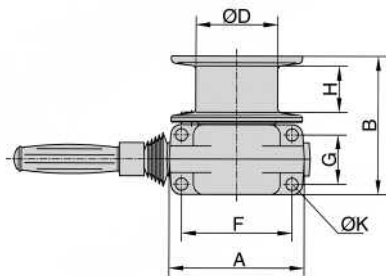
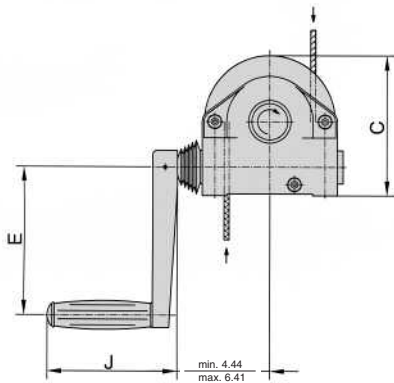

Model No.		030207004V	030208000V
Lifting capacity 1st layer	lbs	1653	2469
upper layer	lbs	1323	1323
Wire rope capacity - total	ft	32 ft., 10 in.	32 ft., 10 in.
Wire rope diameter*	mm	6	7
Drum diameter	in	3 15/16	2 1/2
Lift per crank rotation	in	7/16	7/16
Required crank pressure	lbf	44.96	49.46
Weight	lbs	15	15
A	in	6 1/2	6 1/2
B	in	6 5/8	6 5/8
C	in	6 11/16	6 11/16
Ø D	in	3 15/16	2 1/2
E	in	7 1/16	7 1/16
F	in	5 1/16	5 1/16
G	in	2 3/8	2 3/8
H	in	2 3/16	1 15/16
Ø K	in	1/2	1/2
J	in	6 5/16	6 5/16
L	in	3 3/8	3 3/8

* recommended wire rope DIN 3060 SE-znK-1770 sZ spa lbf = lb. force

SW-K CONSOLE-MOUNTED WIRE ROPE WINCHES

SW-K CONSOLE-MOUNTED WIRE ROPE WINCH BGV C1 (VBG 70)

Spotlight on. The console-mounted wire rope winch makes a grand entrance when used as a drum winch in studios and theatres, convention halls and warehouses – ideal for use wherever heavy objects weighing up to 661 lbs. must be securely moved overhead. A double-acting retaining spring reliably holds the load in every position. It is driven by a single-stage, spur toothed pair of internal geared wheels.

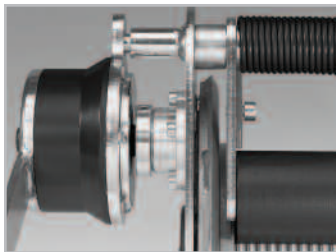
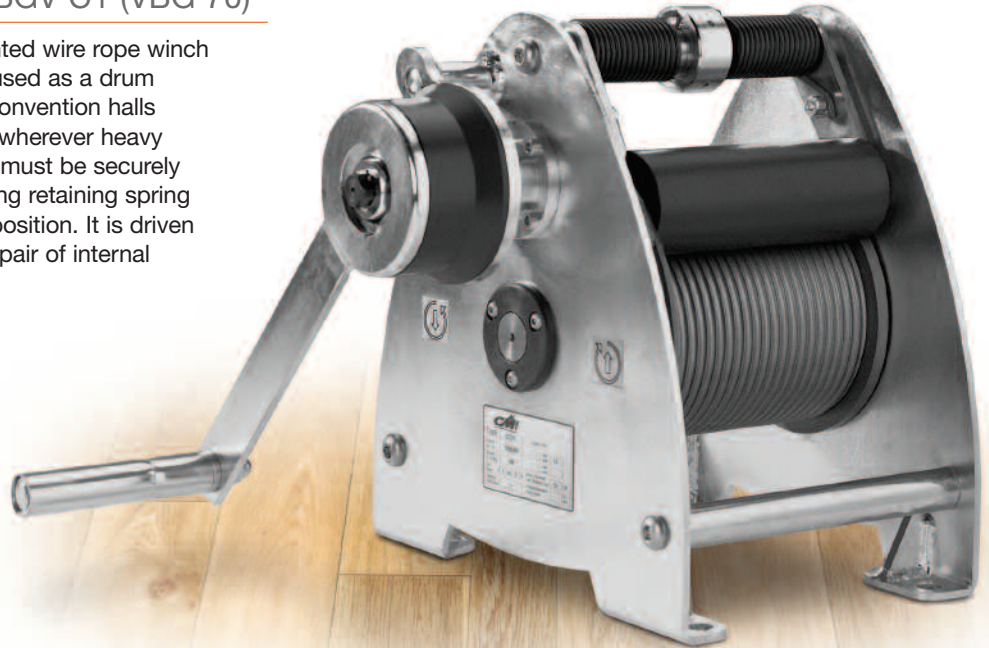

Options:

- Wall Bracket
- Drum with Multiple Cable Grooves

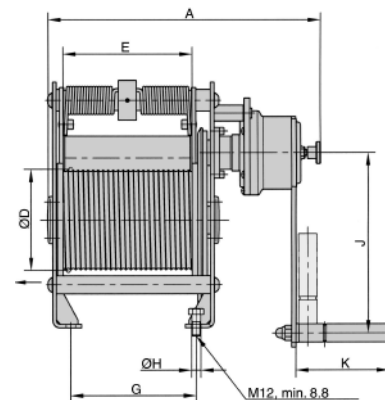
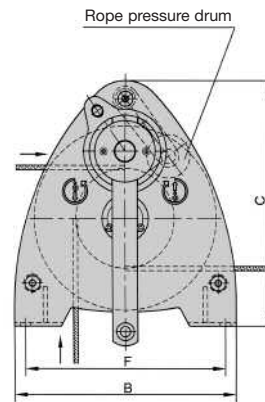

Model No.		030272015V	030272017V
Lifting capacity	lbs	661	661
Drive group DIN 15020/1		2m	2m
Max. wire rope capacity in 1 lay.	ft	32 ft., 10 in.	49 ft., 3 in.
Wire rope diameter*	mm	1/4	1/4
Req. crank press. at max. load	lbf	40.47	40.47
Transmission ratio		8,83:1	8,83:1
Lift per crank rotation	in	1 15/16	1 15/16
Weight	lbs	66	79
Lift	m	32 ft., 10 in.	49 ft., 3 in.
A	in	14 15/16	18 7/16
B	in	12 3/16	12 3/16
C	in	13 3/8	13 3/8
Ø D	in	5 1/4	5 1/4
E	in	7 1/16	10 3/8
F	in	11	11
G	in	6 7/8	10 7/16
Ø H	in	1/2	1/2
J	in	9 13/16	9 13/16
K	in	5 1/8	5 1/8

* recommended steel rope 6 DIN 3069 SE-znk-1960-sZ-spa, (calc. breaking stress min. 30,4 kN)
lbf = lb. force

E N T E R T A I N M E N T T E C H N O L O G Y

SHEAVES & SHEAVE BLOCKS

HAND WINCH ACCESSORIES

DSR SHEAVES

The steel DSR sheaves feature a wear-resistant rope guide where the machine groove is perfectly adjusted to the wire rope. Fifteen different types guarantee a made-to-specification solution at loads of up to 8 tons. The sheaves can be varied in wire and sheave diameter (from 3.125" up to 19.3125") – and as standard all sheaves are equipped with ball bearings. The sheaves are one of the guiding elements within the comprehensive CM product range of wire rope winches, wire rope and wire rope pulley blocks.

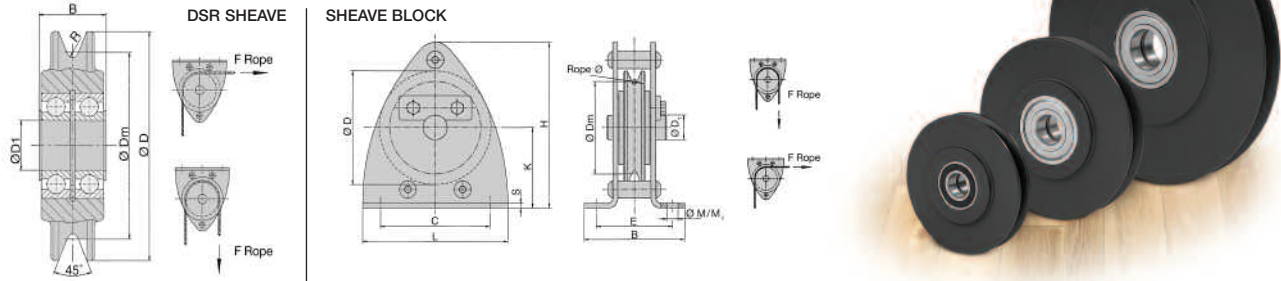

DSR Sheave Model No.	Type	D inch	Rope diameter mm	Dm inch	Drive group FEM	Tensile load lbs at deflection		Ball bearing	D1 Ø mm	R inch	B inch
						90°	180°				
33447202	DSR S 80/4	3 1/8	4	2 5/8	1Bm	1543	1102	6004ZZ	20	1/16	1 1/8
33447403	DSR S 90/6	3 3/16	6	3 1/8	1Dm	1543	1102	6004ZZ	20	2/16	1 1/8
33447204	DSR S 145/5	5 11/16	5	4 15/16	4m	2425	1764	6205ZZ	25	1/8	1 5/16
33447205	DSR S 145/6	5 11/16	6	4 15/16	2m	2425	1764	6205ZZ	25	1/8	1 5/16
33447206	DSR S 145/7	5 11/16	7	4 15/16	1Am	2425	1764	6205ZZ	25	1/8	1 5/16
33447207	DSR S 185/8	7 5/16	8	6 9/16	2m	5071	3594	6306ZZ	30	3/16	1 5/8
33447208	DSR S 185/9	7 5/16	9	6 3/8	1Am	5071	3594	6306ZZ	30	3/16	1 5/8
33447209	DSR S 270/10	10 9/8	10	9 9/8	3m	5512	3968	6208ZZ	40	1/4	1 5/8
33447210	DSR S 270/11	10 9/8	11	9 3/4	3m	5512	3968	6208ZZ	40	1/4	1 5/8
33447211	DSR S 270/12	10 9/8	12	9 11/16	2m	5512	3968	6208ZZ	40	1/4	1 5/8
33447212	DSR S 270/13	10 9/8	13	9 5/8	1Am	5512	3968	6208ZZ	40	1/4	1 5/8
33447217	DSR S 325/14	12 13/16	14	11 11/16	2m	9921	7055	6310ZZ	50	3/16	2 3/8
33447213	DSR S 400/16	15 3/4	16	14 1/2	3m	11023	8378	6310ZZ	50	5/16	2 3/8
33447214	DSR S 400/18	15 3/4	18	14 3/16	2m	11023	8378	6310ZZ	50	3/8	2 3/8
33447215	DSR S 490/20	19 5/16	20	17 11/16	3m	17637	13228	6313ZZ	65	7/16	2 13/16

Sheave Block Model No.	Type	D Ø inch	Rope diameter mm	Dm Ø inch	Drive group FEM	Max. tensile load lbs at deflection		Ball bearing	D1 Ø inch	L Ø inch	C inch	H inch	B inch	E inch	S inch	K inch	M/M1 Ø inch
						90°	180°										
033447103V	DSRB S 90/4	3 9/16	3-4	3 3/8	2m	1543	1102	6004ZZ	1 1/16	4 3/4	3 9/16	5 1/4	3 3/8	2 7/16	3/16	2 9/16	3/8, 3/8
033447413V	DSRB S 90/6	3 9/16	5-6	3 1/16	1Dm	1543	1102	6205ZZ	1	4 3/4	3 9/16	5 1/4	3 3/8	2 7/16	1/4	2 9/16	3/8, 3/8
033447106V	DSRB S 145/7	5 11/16	7	4 15/16	1Am	2425	1764	6306ZZ	1	7 7/8	6 5/16	8 13/16	4 15/16	3 7/16	1/4	4 5/16	7/16, 1/2
033447107V	DSRB S 185/8	7 5/16	8	6 5/16	2m	5071	3594	6306ZZ	1 3/16	9 9/8	7 11/16	10 13/16	5 7/16	4 3/16	5/16	5 5/16	9/16, 9/16
033447111V	DSRB S 270/12	10 9/8	9-12	9 11/16	2m	5512	3968	6208ZZ	1 9/16	14 3/16	11 7/16	16	7 1/2	5 7/16	3/8	7 15/16	1 1/16, 13/16
033447113V	DSRB S 400/16	15 3/4	13-16	14 1/2	3m	11023	8378	6310ZZ	1 5/16	20 7/8	16 15/16	24 1/8	11 7/8	8 3/8	9/16	12 3/16	1, 1 1/16
033447115V	DSRB S 490/20	19 5/16	20	17 3/4	3m	17637	13228	6313ZZ	2 9/16	25 1/16	22 13/16	27 5/16	12 5/16	8 11/16	5/8	13 3/8	1 5/16, 1 9/16

All wire cable reels are also available individually on request.

STANDARD CABLES FOR CM HAND WINCHES

Galvanized 6 x 19 design in accordance with DIN 3060, with fiber inlay at one end with pressed in thimble and ultra-strong safety hook, and point-cut (blunt) at the other. Please refer to the table below for the order number required, taking account of the cable diameter and length.

Rope Diameter	Calculated breaking strength	Rope lengths				Lifting capacity of eye hooks
		16.4 ft	32.8 ft	49.2 ft	65.6 ft	
4 mm - DIN 3060	2270 lbs	033600405V	033600410V	033600415V	033600420V	1100 lbs
5 mm - DIN 3060	3550 lbs	033600505V	033600510V	033600515V	033600520V	2200 lbs
6 mm - DIN 3060	5125 lbs	033600605V	033600610V	033600615V	033600620V	2200 lbs
7 mm - DIN 3060	6968 lbs	033600705V	033600710V	033600715V	033600720V	2200 lbs
7 mm - DIN 3069*	9868 lbs	-	-	033601715V	-	3520 lbs

* Cable with higher breaking strength for wire rope winch LB 2,645 lbs.

ADDITIONAL ACCESSORIES AVAILABLE ON REQUEST

- Cable suspension gear (1 to 4-strand)
- Sling ropes with loops at both ends
- High-strength shackles
- Gibs and cotters, turnbuckles
- Wire cable blocks with hooks and swivel eyes
- Hinged wire cable blocks
- Wire rope sheave block with plastic sheave