

MODEL

EMC-CRELECTRIC CHAIN HOISTS
FOR CLEAN ROOM APPLICATIONSHigh Performance Lifting
COFFING®
HOISTS

THE SOLUTION FOR CLEAN ROOM APPLICATIONS

COFFING EMC-CR – Compact chain hoists designed for clean room applications. From Computer Processors to Medical / Pharmaceutical Products, the EMC-CR's unique lift wheel design makes it the ideal hoist for clean room environments. There is no metal-to-metal contact between the chain lift wheel and the load chain.

CAPACITIES AND LIFT – Rated loads of 300 and 500 pounds, 10 feet of lift with 6 feet of push button control cord standard.

STAINLESS STEEL SUSPENSION AND LOAD CHAIN – Stainless Steel load chain / Swivel top and bottom Stainless Steel Hooks and Safety Latches

VOLTAGE AND POWER CORD – 115V single phase / Grounded 3-prong 18 inch power cord included. Can be powered by any standard 115V outlet.

LIMIT SWITCHES – Upper and Lower Limit Switches are standard.

ELECTROMAGNETIC BRAKE – Quick acting for positive load control.

THERMAL MOTOR PROTECTION – Standard to prevent overheating.

HOIST BODY – Unpainted Aluminum housing is lightweight and compact. The complete unit weighs less than 25 pounds.

LIFETIME WARRANTY



300 & 500 lb.

MADE IN USA

COFFING®
HOISTS

● SPECIFICATIONS ●

Capacity (lb.)	Model Number	No. of Chains	Standard Lift (ft.)	Motor HP	Lift Speed (fpm)	Headroom (in.)	Housing Dimensions (in.)			Net Wt. (lb.)
							H	W	L	
300	EMC-300 CR	1	10	1/6	16	14 1/2	4 3/8	6 3/8	14 1/4	21
500	EMC-500 CR	2	10	1/6	8	16	4 3/8	6 3/8	14 1/4	24

MODEL

EMC-CR



ELECTRIC CHAIN HOISTS
FOR CLEAN ROOM APPLICATIONS



High Performance Lifting
COFFING®
HOISTS

DIMENSIONAL DRAWINGS

EMC-CR 300

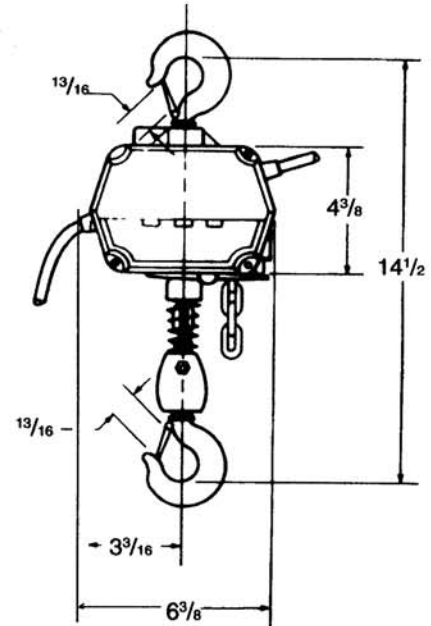
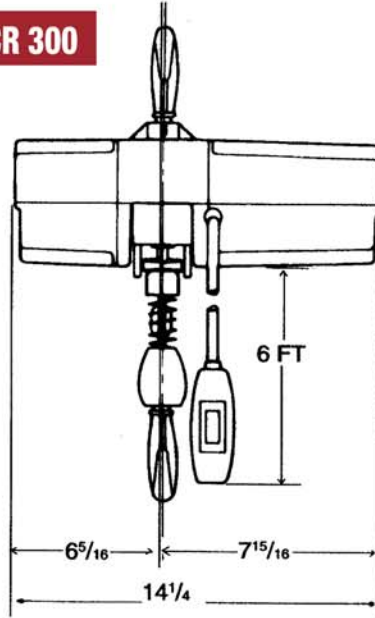

EMC-CR 500

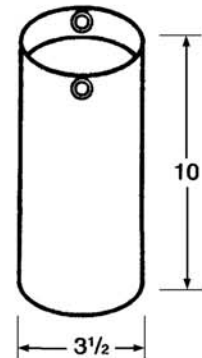
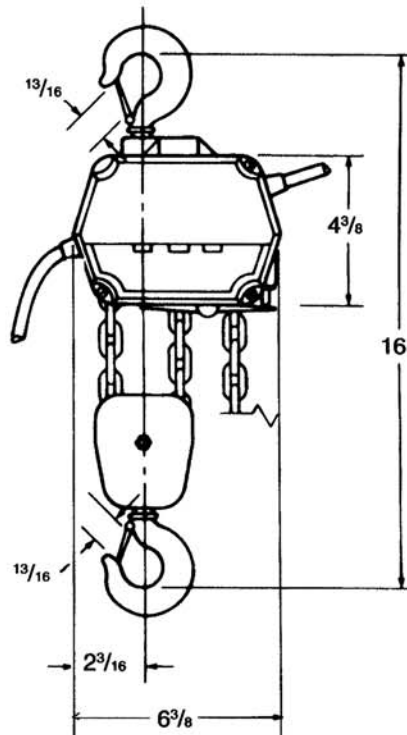
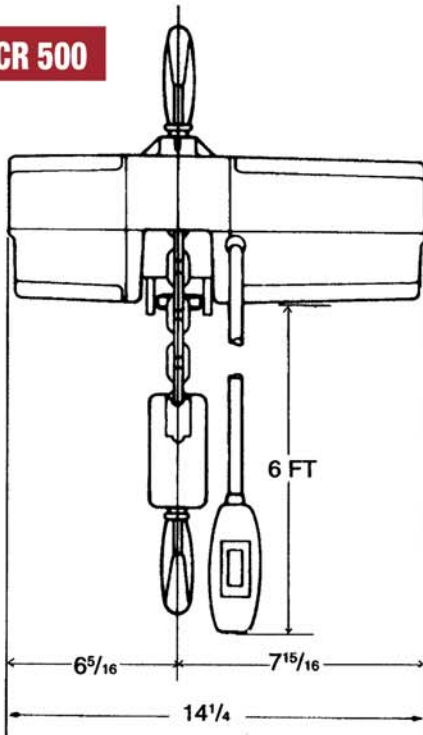

**CHAIN
CONTAINER**
For EMC Models

⚠ WARNING

Overloading and Improper Use Can Result In Injury

- To Avoid Injury:
- Do not exceed working load limit, load rating, or capacity.
 - Do not use to lift people or loads over people.
 - Use only alloy chain and attachments for overhead lifting.
 - Read and follow all instructions.

COFFING®
HOISTS