

SHAW-BOX[®]
800 SERIES,
700 SERIES SIZE 2

Drawings and Specifications Book



Monorail Hoists

- Electric
- Air
- Explosion Proof

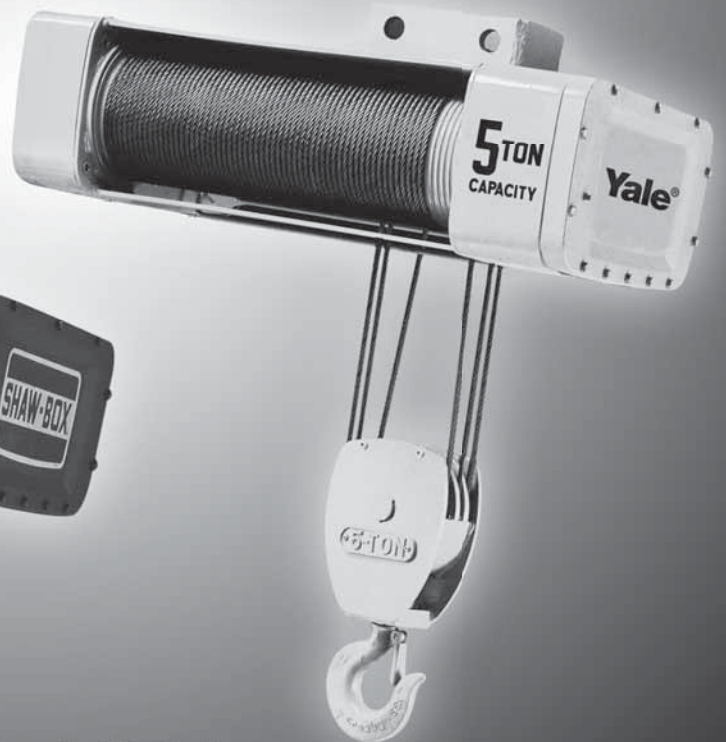

- Deck Hoists
- Top-Running Trolleys

This catalog contains dimensions and specifications for the Shaw-Box 800 Series, 700 Series Size 2 and the Yale Y80 Series Wire Rope Hoists. If a desired hoist or hoist option is not found in this booklet please consult your CMCO Sales Representative.

Note: This booklet contains dimensions and specifications only for hoists with motor driven trolleys. For drawings of hoists that are lug mounted or with hand-push or hand-gearred trolley, go to www.cmworks.com.

Index

Subject Page No.

Yale Y80/Shaw-Box 800 Series Electric Hoists

Single Reeved Standard Specifications & Drawing

Standard Specifications	3
1/2-ton - 25' lift	4
1/2-ton - 50' lift	5
1-ton - 25' lift.....	6
1-ton - 50' lift.....	7
2-ton - 20 & 40' lift	8
3-ton - 30' lift.....	9
3-ton - 45' lift.....	10
5-ton - 20' lift.....	11
5-ton - 30' lift.....	12

Double Reeved Standard Specifications & Drawings

Standard Specifications	13
1/2-ton - 18' lift	14
1/2-ton - 34' lift	15
1/2-ton - 47' lift	16
1-ton - 18' lift.....	17
1-ton - 34' lift.....	18
1-ton - 47' lift.....	19
2-ton - 14' lift.....	20
2-ton - 25' lift.....	21
2-ton - 36' lift.....	22

Yale Y80/Shaw-Box 800 Series Air Hoists

Single Reeved Standard Specifications & Drawings

Standard Specifications	23
1-ton - 25' lift.....	24
1-ton - 50' lift.....	25
2-ton - 20' lift.....	26
2-ton - 40' lift.....	27
3-ton - 30' lift.....	28
3-ton - 45' lift.....	29
5-ton - 20' lift.....	30
5-ton - 30' lift.....	31

Double Reeved Standard Specifications & Drawings

Standard Specifications	32
1-ton - 18' lift.....	33
1-ton - 34' lift.....	34
2-ton - 14' lift.....	35
2-ton - 25' lift.....	36

Shaw-Box 700 Series Size 2 Electric Hoists

Single Reeved Standard Specifications & Drawings

Standard Specifications	37
3-ton 26' lift	38
5-ton - 26' lift.....	39
5-ton - 47' lift.....	40
7-1/2-ton - 22' lift.....	41
7-1/2-ton - 38' lift.....	42
10-ton 25' lift	43

Index

Subject Page No.

Shaw-Box 700 Series Size 2 Electric Hoists

Double Reeved Standard Specifications & Drawing

Standard Specifications	44
1-ton - 83' lift.....	45
3-ton - 27' lift.....	46
3-ton - 50' lift.....	47
5-ton - 18' lift.....	48
5-ton - 35' lift.....	49
7-1/2-ton - 23' lift	50

Single Reeved Deck Hoists Specifications & Drawings

Standard Specifications	51
3-ton - 26' & 44' lift	52
3-ton - 55' lift.....	53
5-ton - 26' & 47' lift	54
7-1/2-ton - 12', 22' & 38' lift.....	55
10-ton - 15', 25, & 40' lift	56

Standard Features	Dimensions & Specifications	ELECTRIC WIRE ROPE	Y80 - 800 Series		
--------------------------	--	---------------------------	-------------------------	--	--

Single Reeved Electric Hoists with Motor Driven Trolleys

Feature	1/2 Ton	1 Ton	2 Ton	3 Ton	5 Ton
Service Class	H-4	H-4	H-4	H-4	H-4
Reeved	2 PS - 1/4"	2 PS - 1/4"	2 PS - 5/16"	4 PS - 5/16"	6 PS - 5/16"
Hoist Gearing	Triple reduction Helical/Spur	Triple reduction Helical/Spur	Triple reduction Helical/Spur	Triple reduction Helical/Spur	Triple reduction Helical/Spur
Hook Assembly	Bearing Thrust Washer 360 degree rotate	Bearing Thrust Washer 360 degree rotate	Bearing Thrust Washer 360 degree rotate	Bearing-mounted 360 degree rotate	Bearing-mounted 360 degree rotate
Hoist Motor	30-minute rated TENV	30-minute rated TENV	30-minute rated TENV	30-minute rated TENV	30-minute rated TENV
Hoist Motor Brake (AC)	100% Torque disc	100% Torque disc	100% Torque disc	100% Torque disc	100% Torque disc
Load Brake	Weston type Roller Ratchet	Weston type Roller Ratchet	Weston type Roller Ratchet	Weston type Roller Ratchet	Weston type Roller Ratchet
Hoist Control	1-speed	1-speed	1-speed	1-speed	1-speed
Control Circuit voltage	115 Volts	115 Volts	115 Volts	115 Volts	115 Volts
Hoist Limit Switch	Upper block control circuit	Upper block control circuit	Upper block control circuit	Upper block control circuit	Upper block control circuit
Rope Drum Diameter	7-1/2"	7-1/2"	7-1/2"	7-1/2"	7-1/2"
Rope Drum Material	Cast Iron	Cast Iron	Cast Iron	Cast Iron	Cast Iron
Sheave Diameter	5"	5"	6"	6"	6"
Sheave Material	Steel	Steel	Steel	Steel	Steel
Trolley Gearing	Worm	Worm	Worm	Worm	Worm
Trolley Motor	30-minute rated TENV	30-minute rated TENV	30-minute rated TENV	30-minute rated TENV	30-minute rated TENV
Trolley Brake	Optional AC Disc	Optional AC Disc	Optional AC Disc	Optional AC Disc	Optional AC Disc
Trolley Control	1-speed	1-speed	1-speed	1-speed	1-speed
Wheels	4"	4"	4"	4" for 45' lift 6-1/2" for 30' lift	6-1/2"
Bumpers	Optional Rubber	Optional Rubber	Optional Rubber	Optional Rubber	Optional Rubber
Bearings	Anti-friction	Anti-friction	Anti-friction	Anti-friction	Anti-friction
Motor TAS	Standard	Standard	Standard	Standard	Standard
Control Enclosure	NEMA 1	NEMA 1	NEMA 1	NEMA 1	NEMA 1

Single Reeved

1/2 Ton

ELECTRIC WIRE ROPE

Y80 - 800 Series

MOTOR DRIVEN TROLLEY

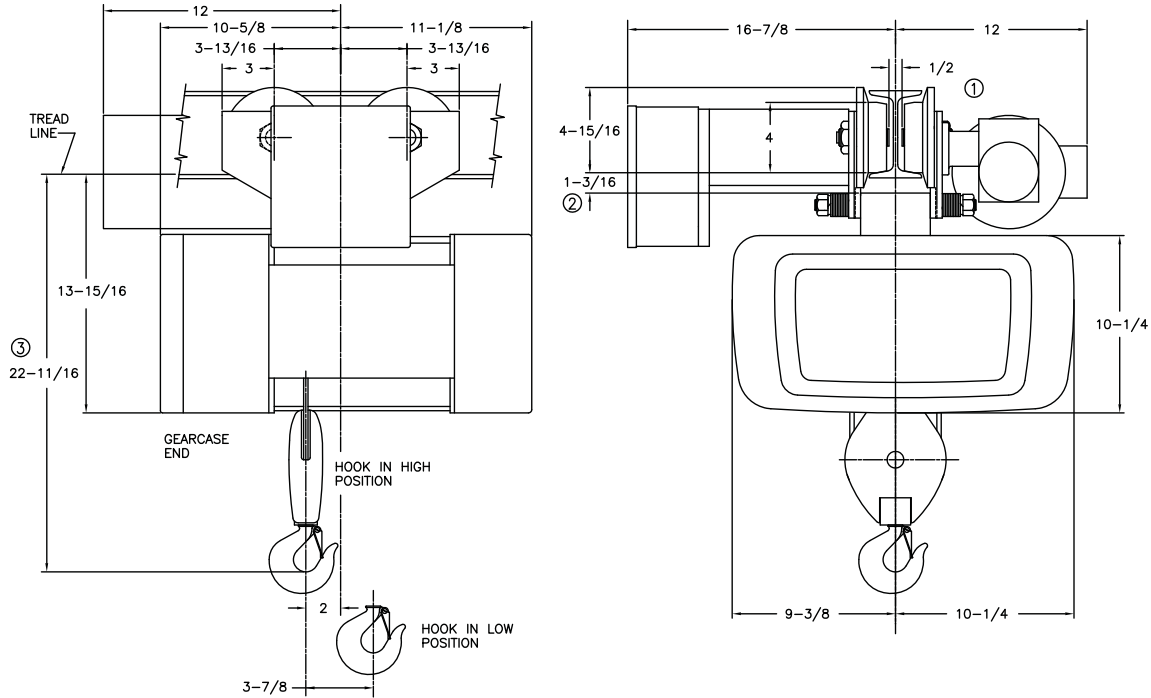

MINIMUM RADIUS: 3'-6"

CATALOG NUMBER	HOIST				TROLLEY		WEIGHT (LBS)	ESTIMATED WHEEL LOAD*	
	MAX LIFT (FT)	HOIST SPEED (FPM)	HP	ROPE NO & DIA	SPEED (FPM)	HP		HIGH HOOK (LBS)	LOW HOOK (LBS)
†80M.5-025S18-1	25	18	1	2-1/4	75	1/4	260	507	498
†80M.5-025S18-2	25	18/6	1/33	2-1/4	75	1/4	301	519	509
†80M.5-025S35-1	25	35	2	2-1/4	75	1/4	260	511	502
†80M.5-025S35-2	25	35/11.7	2/.66	2-1/4	75	1/4	301	522	513
†80M.5-025S50-1	25	50	4	2-1/4	75	1/4	291	550	540
†80M.5-025S50-2	25	50/16.6	3/1	2-1/4	75	1/4	332	561	551

Weights shown are for standard hoists listed. For approximate shipping weights, add 110 lbs. to the net weight given. Consult factory for weights of special hoists. Dimensions shown are in inches unless otherwise noted.

When used on smallest I-beam size, beam must be free of all obstructions, such as clips, suspension bolts, and nuts. Trolleys for wide flange beams refer to Optional Equipment.

Trolley beam size range – beam flange width 3" min., 5" max; beam depth 6" min. standard, 5-1/8"-7-1/4" with 1st extension, 7-1/2"-9-1/8" with 2nd extension. See Optional Price section for extension pricing.

① Occurs on smallest beam size only. On larger beams, it is increased by the difference in flange width.

② Clearance shown is between lug and wheel tread.

③ Dimension increases 3" when hoist is equipped with screw type limit switch.

* Estimated wheel load per one (1) wheel. Includes live and dead load impacts.

† For a Y80 add a "Y" prefix.

Single Reeved

1/2 Ton

ELECTRIC WIRE ROPE

Y80 - 800 Series

MOTOR DRIVEN TROLLEY

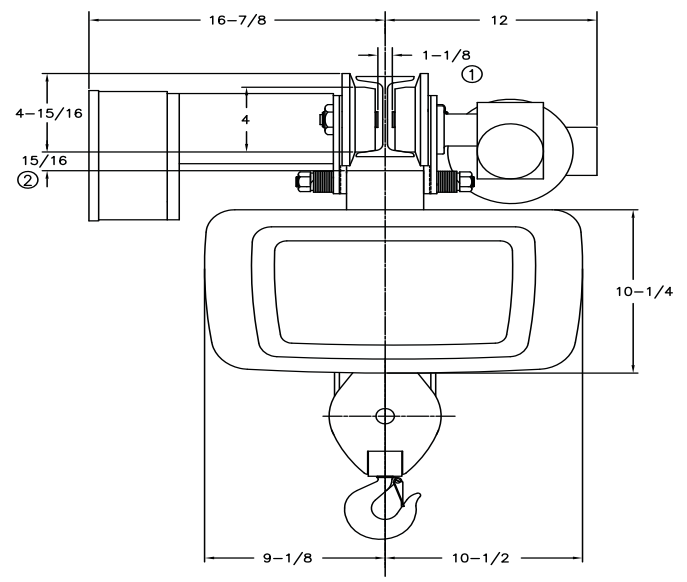
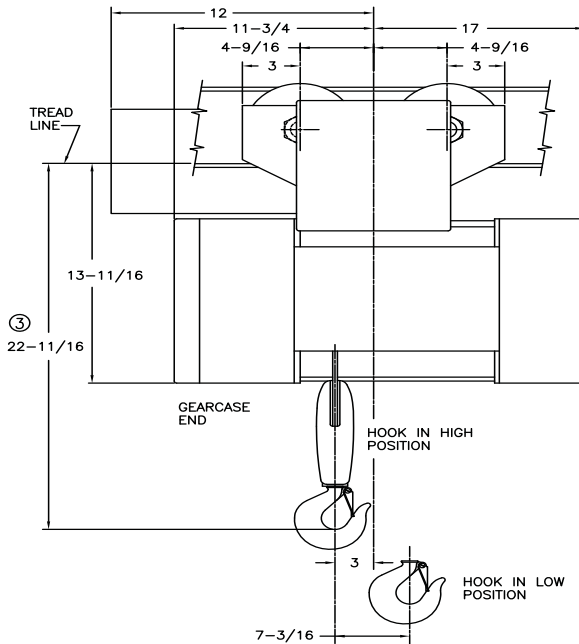

MINIMUM STANDARD RADIUS: 5'-0", FOR SMALLER RADIUS CONTACT FACTORY

CATALOG NUMBER	HOIST				TROLLEY		WEIGHT (LBS)	ESTIMATED WHEEL LOAD*	
	MAX LIFT (FT)	HOIST SPEED (FPM)	HP	ROPE NO & DIA	SPEED (FPM)	HP		HIGH HOOK (LBS)	LOW HOOK (LBS)
†80M.5-050S18-1	50	18	1	2-1/4	60	1/4	385	582	657
†80M.5-050S18-2	50	18/6	1/3.3	2-1/4	60	1/4	420	592	667
†80M.5-050S35-1	50	35	2	2-1/4	60	1/4	385	587	662
†80M.5-050S35-2	50	35/11.7	2/6.6	2-1/4	60	1/4	420	596	672
†80M.5-050S50-1	50	50	4	2-1/4	60	1/4	416	628	709
†80M.5-050S50-2	50	50/16.6	3/1	2-1/4	60	1/4	451	638	719

Weights shown are for standard hoists listed. For approximate shipping weights, add 110 lbs. to the net weight given. Consult factory for weights of special hoists. Dimensions shown are in inches unless otherwise noted.

When used on smallest I-beam size, beam must be free of all obstructions, such as clips, suspension bolts, and nuts. Trolleys for wide flange beams refer to Optional Equipment.

Trolley beam size range – beam flange width 3-5/8" min., 6-1/4" max; beam depth 6" min. standard, 6-1/4"-8-5/8" with 1st extension, 8-7/8"-11-1/4" with 2nd extension. See Optional Price section for extension pricing.

① Occurs on smallest beam size only. On larger beams, it is increased by the difference in flange width.

② Clearance shown is between lug and wheel tread.

③ Dimension increases 3" when hoist is equipped with screw type limit switch.

* Estimated wheel load per one (1) wheel. Includes live and dead load impacts.

† For a Y80 add a "Y" prefix.

Single Reeved

1 Ton

ELECTRIC WIRE ROPE

Y80 - 800 Series

MOTOR DRIVEN TROLLEY

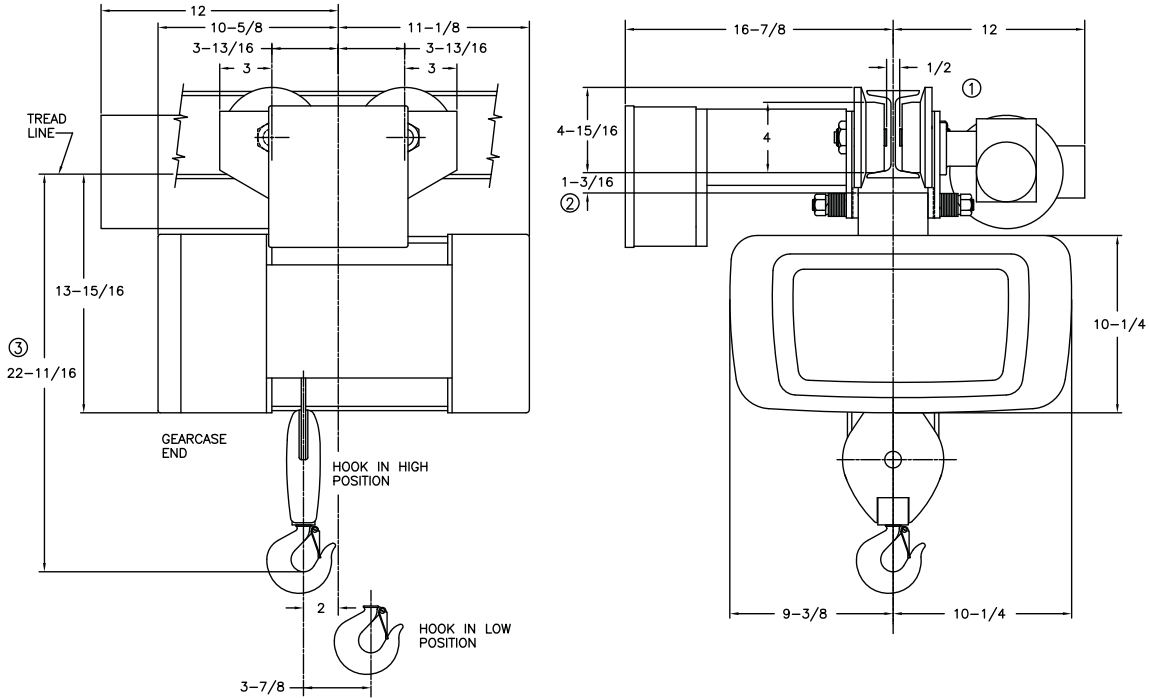

MINIMUM RADIUS: 3'-6"

CATALOG NUMBER	HOIST				TROLLEY		WEIGHT (LBS)	ESTIMATED WHEEL LOAD*	
	MAX LIFT (FT)	HOIST SPEED (FPM)	HP	ROPE NO & DIA	SPEED (FPM)	HP		HIGH HOOK (LBS)	LOW HOOK (LBS)
†80M01-025S18-1	25	18	2	2-1/4	75	1/4	266	945	926
†80M01-025S18-2	25	18/6	2/.66	2-1/4	75	1/4	301	955	936
†80M01-025S28-1	25	28	2	2-1/4	75	1/4	291	959	941
†80M01-025S28-2	25	28/9.4	2/.66	2-1/4	75	1/4	301	962	943
†80M01-025S50-1	25	50	4	2-1/4	75	1/4	291	1020	1000
†80M01-025S50-2	25	50/25	4/2	2-1/4	75	1/4	301	1023	1003

Weights shown are for standard hoists listed. For approximate shipping weights, add 110 lbs. to the net weight given. Consult factory for weights of special hoists. Dimensions shown are in inches unless otherwise noted.

When used on smallest I-beam size, beam must be free of all obstructions, such as clips, suspension bolts, and nuts. Trolleys for wide flange beams refer to Optional Equipment.

Trolley beam size range – beam flange width 3" min., 5" max; beam depth 6" min. standard, 5-1/8"-7-1/4" with 1st extension, 7-1/2"-9-1/8" with 2nd extension. See Optional Price section for extension pricing.

① Occurs on smallest beam size only. On larger beams, it is increased by the difference in flange width.

② Clearance shown is between lug and wheel tread.

③ Dimension increases 3" when hoist is equipped with screw type limit switch.

* Estimated wheel load per one (1) wheel. Includes live and dead load impacts.

† For a Y80 add a "Y" prefix.

Single Reeved

1 Ton

ELECTRIC WIRE ROPE

Y80 - 800 Series

MOTOR DRIVEN TROLLEY

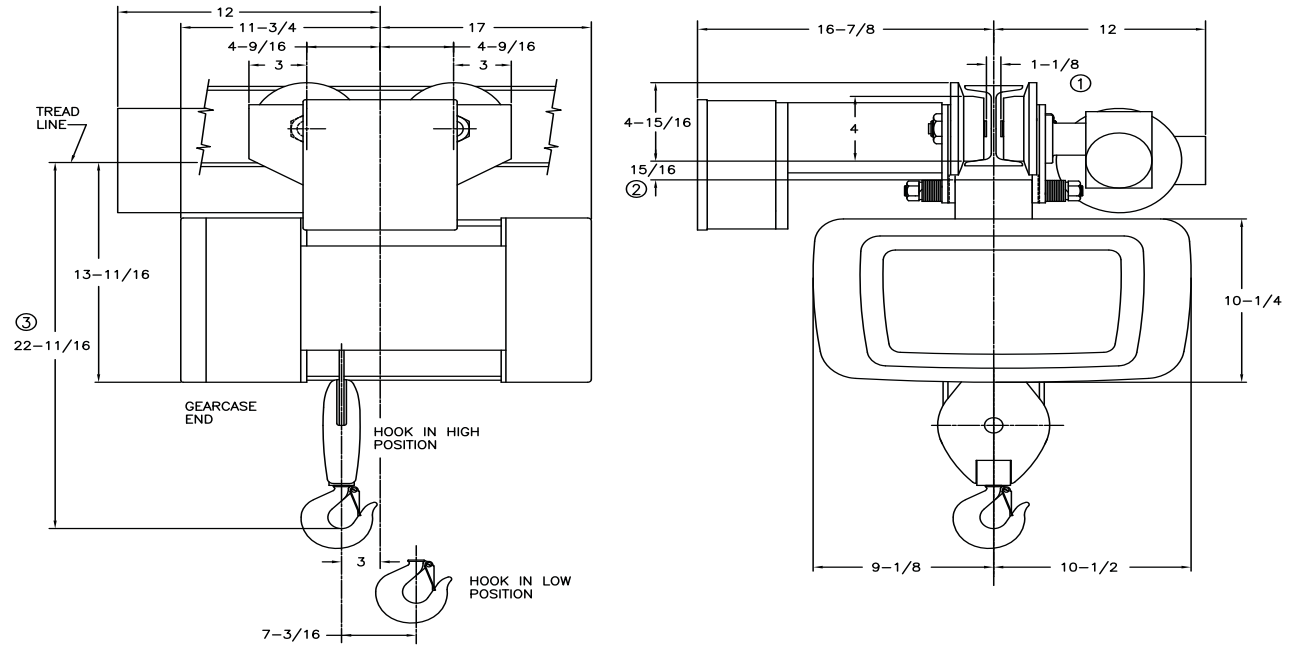

MINIMUM STANDARD RADIUS: 5'-0", FOR SMALLER RADIUS CONTACT FACTORY

CATALOG NUMBER	HOIST				TROLLEY		WEIGHT (LBS)	ESTIMATED WHEEL LOAD*	
	MAX LIFT (FT)	HOIST SPEED (FPM)	HP	ROPE NO & DIA	SPEED (FPM)	HP		HIGH HOOK (LBS)	LOW HOOK (LBS)
†80M01-050S18-1	50	18	2	2-1/4	60	1/4	385	1059	1209
†80M01-050S18-2	50	18/6	2/.66	2-1/4	60	1/4	420	1069	1218
†80M01-050S28-1	50	28	2	2-1/4	60	1/4	415	1075	1226
†80M01-050S28-2	50	28/9.4	2/.66	2-1/4	60	1/4	420	1077	1228
†80M01-050S50-1	50	50	4	2-1/4	60	1/4	415	1142	1303
†80M01-050S50-2	50	50/25	4/2	2-1/4	60	1/4	420	1143	1305

Weights shown are for standard hoists listed. For approximate shipping weights, add 110 lbs. to the net weight given. Consult factory for weights of special hoists. Dimensions shown are in inches unless otherwise noted.

When used on smallest I-beam size, beam must be free of all obstructions, such as clips, suspension bolts, and nuts. Trolleys for wide flange beams refer to Optional Equipment.

Trolley beam size range – beam flange width 3-5/8" min., 6-1/4" max; beam depth 6" min. standard, 6-1/4"-8-5/8" with 1st extension, 8-7/8"-11-1/4" with 2nd extension. See Optional Price section for extension pricing.

① Occurs on smallest beam size only. On larger beams, it is increased by the difference in flange width.

② Clearance shown is between lug and wheel tread.

③ Dimension increases 3" when hoist is equipped with screw type limit switch.

* Estimated wheel load per one (1) wheel. Includes live and dead load impacts.

† For a Y80 add a "Y" prefix.

Single Reeved

2 Ton

ELECTRIC WIRE ROPE

Y80 - 800 Series

MOTOR DRIVEN TROLLEY

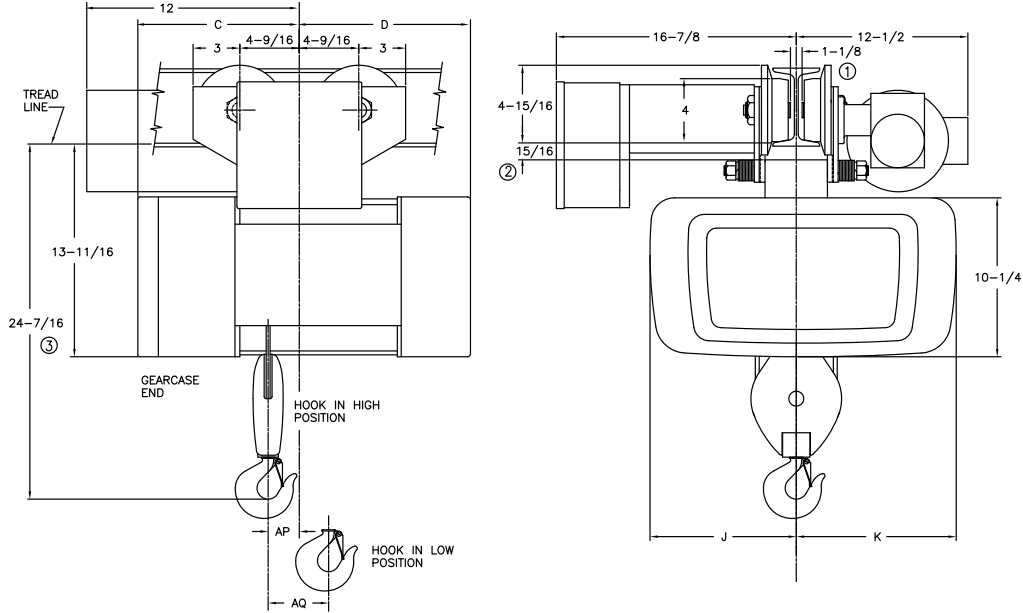

MINIMUM STANDARD RADIUS: 5'-0", FOR SMALLER RADIUS CONTACT FACTORY

CATALOG NUMBER	HOIST				TROLLEY		WEIGHT (LBS)	C	D	J	K	AP	AQ	ESTIMATED WHEEL LOAD*	
	MAX LIFT (FT)	HOIST SPEED (FPM)	HP	ROPE NO & DIA	SPEED (FPM)	HP								HIGH HOOK (LBS)	LOW HOOK (LBS)
†80M02-020S14-1	20	14	2	2-5/16	60	1/4	385	10-5/8	11-1/8	9-3/8	10-1/4	2	3-7/8	1760	1728
†80M02-020S14-2	20	14/4.66	2/.66	2-5/16	60	1/4	400	10-5/8	11-1/8	9-3/8	10-1/4	2	3-7/8	1764	1733
†80M02-020S28-1	20	28	4	2-5/16	60	1/4	385	10-5/8	11-1/8	9-3/8	10-1/4	2	3-7/8	1760	1728
†80M02-020S28-2	20	28/14	4/2	2-5/16	60	1/4	400	10-5/8	11-1/8	9-3/8	10-1/4	2	3-7/8	1764	1733
†80M02-040S14-1	40	14	2	2-5/16	60	1/4	410	11-3/4	17	9-1/8	10-1/2	3	7-3/8	2019	2365
†80M02-040S14-2	40	14/4.66	2/.66	2-5/16	60	1/4	425	11-3/4	17	9-1/8	10-1/2	3	7-3/8	2023	2370
†80M02-040S28-1	40	28	4	2-5/16	60	1/4	410	11-3/4	17	9-1/8	10-1/2	3	7-3/8	2019	2365
†80M02-040S28-2	40	28/14	4/2	2-5/16	60	1/4	425	11-3/4	17	9-1/8	10-1/2	3	7-3/8	2023	2370

Weights shown are for standard hoists listed. For approximate shipping weights, add 110 lbs. to the net weight given. Consult factory for weights of special hoists. Dimensions shown are in inches unless otherwise noted.

When used on smallest I-beam size, beam must be free of all obstructions, such as clips, suspension bolts, and nuts. Trolleys for wide flange beams refer to Optional Equipment.

Trolley beam size range – beam flange width 3-5/8" min., 6-1/4" max; beam depth 6" min. standard, 6-1/4"-8-5/8" with 1st extension, 8-7/8"-11-1/4" with 2nd extension. See Optional Price section for extension pricing.

① Occurs on smallest beam size only. On larger beams, it is increased by the difference in flange width.

② Clearance shown is between lug and wheel tread.

③ Dimension increases 3" when hoist is equipped with screw type limit switch.

* Estimated wheel load per one (1) wheel. Includes live and dead load impacts.

† For a Y80 add a "Y" prefix.

Single Reeved

3 Ton

ELECTRIC WIRE ROPE

Y80 - 800 Series

MOTOR DRIVEN TROLLEY

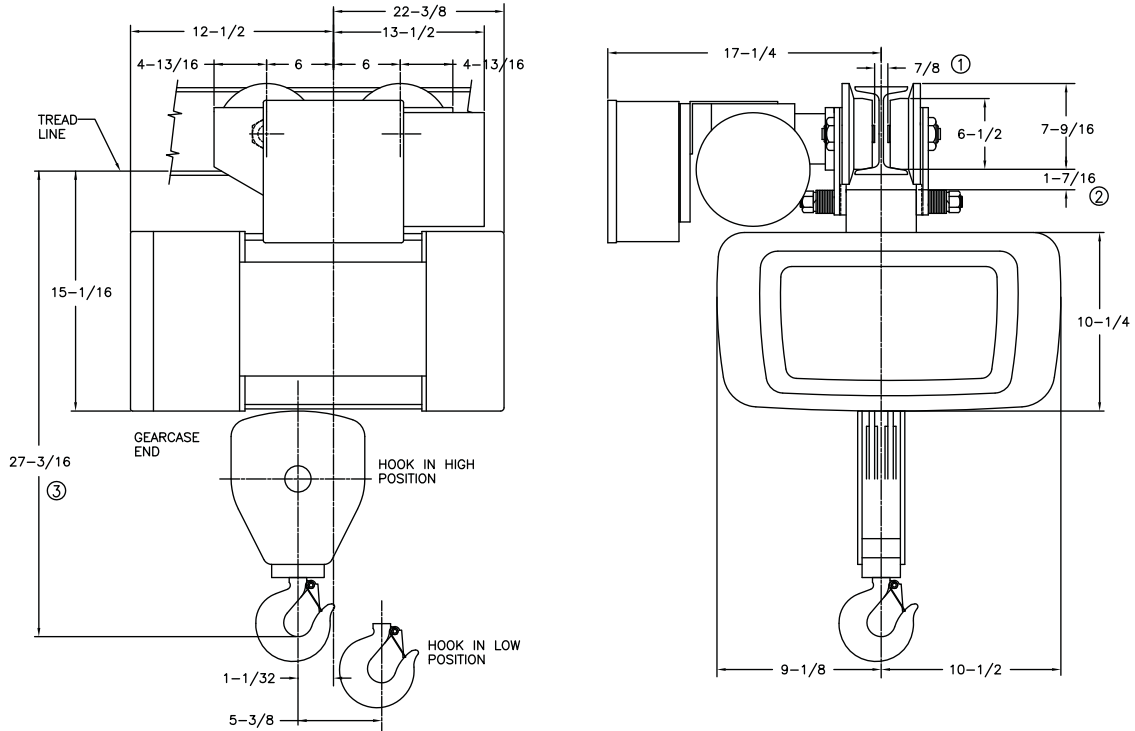

MINIMUM STANDARD RADIUS: 7'-0", FOR SMALLER RADIUS CONTACT FACTORY

CATALOG NUMBER	HOIST				TROLLEY		WEIGHT (LBS)	ESTIMATED WHEEL LOAD*	
	MAX LIFT (FT)	HOIST SPEED (FPM)	HP	ROPE NO & DIA	SPEED (FPM)	HP		HIGH HOOK (LBS)	LOW HOOK (LBS)
†80M03-030S09-1	30	9	2	4-5/16	50	1/2	535	2169	3121
†80M03-030S09-2	30	9/3	2/.66	4-5/16	50	1/2	550	2173	3125
†80M03-030S18-1	30	18	4	4-5/16	50	1/2	525	2166	3118
†80M03-030S18-2	30	18/9	4/2	4-5/16	50	1/2	540	2170	3122

Weights shown are for standard hoists listed. For approximate shipping weights, add 110 lbs. to the net weight given. Consult factory for weights of special hoists. Dimensions shown are in inches unless otherwise noted.

When used on smallest I-beam size, beam must be free of all obstructions, such as clips, suspension bolts, and nuts. Trolleys for wide flange beams refer to Optional Equipment.

Trolley beam size range – beam flange width 4" min., 6-1/4" max; beam depth 8" min. standard, 6-3/8"-8-5/8" with 1st extension, 8-3/4"-11" with 2nd extension. See Optional Price section for extension pricing.

① Occurs on smallest beam size only. On larger beams, it is increased by the difference in flange width.

② Clearance shown is between lug and wheel tread.

③ Dimension increases 3" when hoist is equipped with screw type limit switch.

* Estimated wheel load per one (1) wheel. Includes live and dead load impacts.

† For a Y80 add a "Y" prefix.

Single Reeved

3 Ton

ELECTRIC WIRE ROPE

Y80 - 800 Series

MOTOR DRIVEN TROLLEY

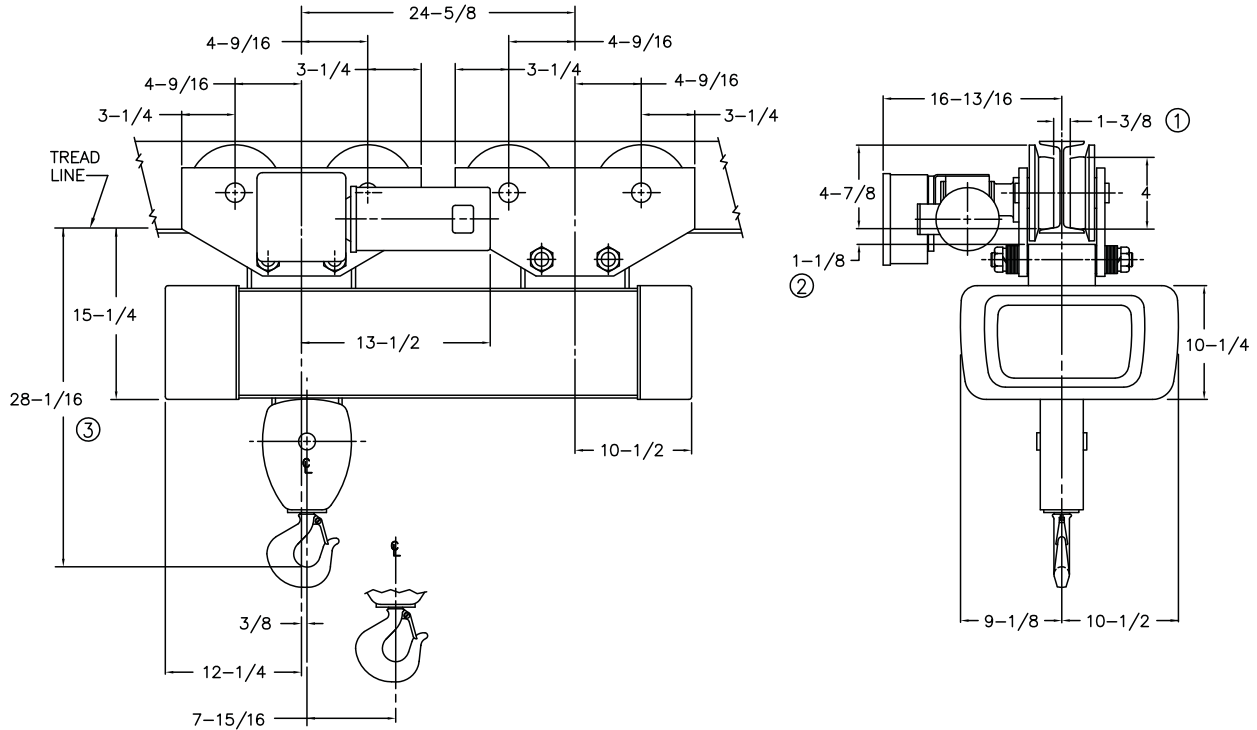

MINIMUM RADIUS: Straight Track ④

CATALOG NUMBER	HOIST				TROLLEY		WEIGHT (LBS)	ESTIMATED WHEEL LOAD*	
	MAX LIFT (FT)	HOIST SPEED (FPM)	HP	ROPE NO & DIA	SPEED (FPM)	HP		HIGH HOOK (LBS)	LOW HOOK (LBS)
†80M03-045S09-1	45	9	2	4-5/16	50	1/2	725	1834	1267
†80M03-045S09-2	45	9/3	2/66	4-5/16	50	1/2	755	1839	1272
†80M03-045S18-1	45	18	4	4-5/16	50	1/2	755	1839	1272
†80M03-045S18-2	45	18/9	4/2	4-5/16	50	1/2	785	1843	1276

Weights shown are for standard hoists listed. For approximate shipping weights, add 110 lbs. to the net weight given. Consult factory for weights of special hoists. Dimensions shown are in inches unless otherwise noted.

When used on smallest I-beam size, beam must be free of all obstructions, such as clips, suspension bolts, and nuts. Trolleys for wide flange beams refer to Optional Equipment.

Trolley beam size range – beam flange width 4" min., 6-1/4" max; beam depth 8" min. standard, 6-3/8"-8-5/8" with 1st extension, 8-3/4"-11" with 2nd extension. See Optional Price section for extension pricing.

① Occurs on smallest beam size only. On larger beams, it is increased by the difference in flange width.

② Clearance shown is between lug and wheel tread.

③ Dimension increases 3" when hoist is equipped with screw type limit switch.

④ Can negotiate curves with addition of swivel trolley option from the pricing section. Headroom increases by 5-1/2".

* Estimated wheel load per one (1) wheel. Includes live and dead load impacts.

† For a Y80 add a "Y" prefix.

**Single
Reeved**

5 Ton

ELECTRIC WIRE ROPE

Y80 - 800 Series

MOTOR DRIVEN TROLLEY

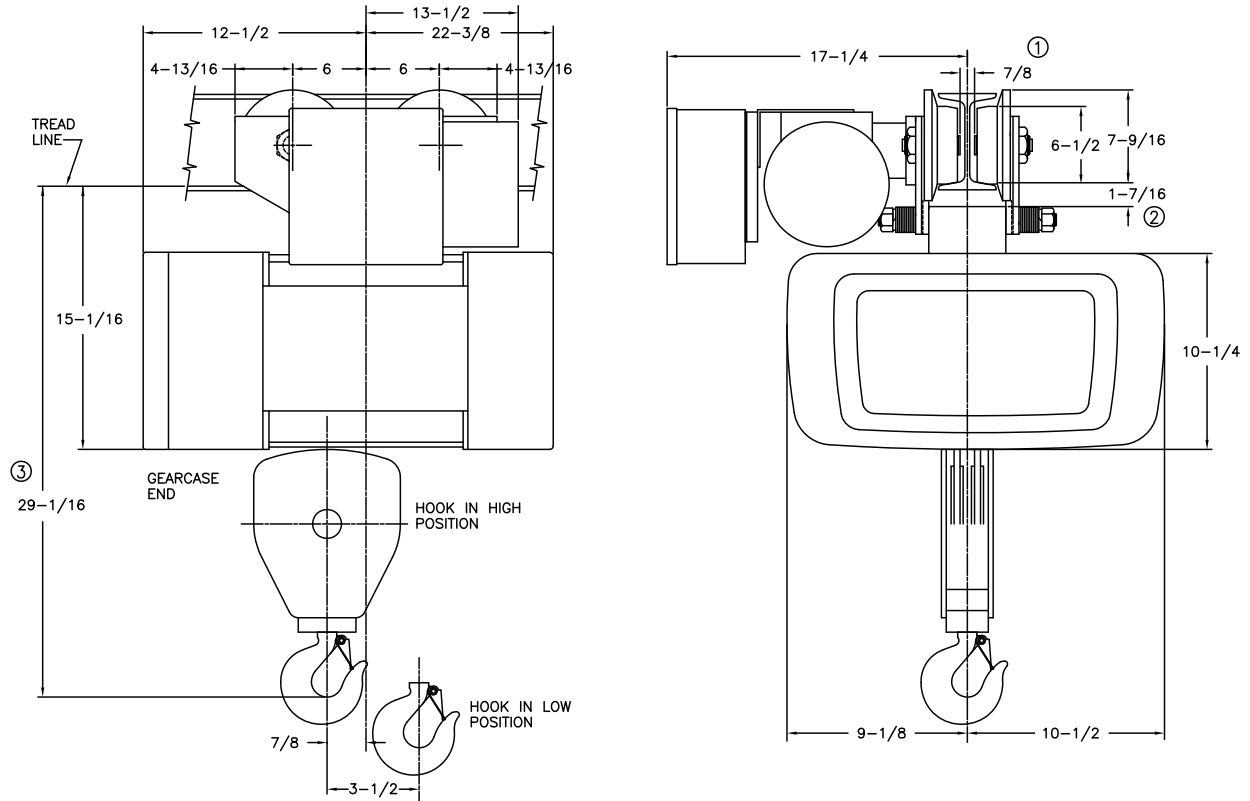

MINIMUM STANDARD RADIUS: 7'-0", FOR SMALLER RADIUS CONTACT FACTORY

CATALOG NUMBER	HOIST				TROLLEY		WEIGHT (LBS)	ESTIMATED WHEEL LOAD*	
	MAX LIFT (FT)	HOIST SPEED (FPM)	HP	ROPE NO & DIA	SPEED (FPM)	HP		HIGH HOOK (LBS)	LOW HOOK (LBS)
†80M05-020S10-1	20	10	4	6-5/16	50	1/2	545	3444	4283
†80M05-020S10-2	20	10/5	4/2	6-5/16	50	1/2	560	3448	4287

Weights shown are for standard hoists listed. For approximate shipping weights, add 110 lbs. to the net weight given. Consult factory for weights of special hoists. Dimensions shown are in inches unless otherwise noted.

When used on smallest I-beam size, beam must be free of all obstructions, such as clips, suspension bolts, and nuts. Trolleys for wide flange beams refer to Optional Equipment.

Trolley beam size range – beam flange width 4" min., 6-1/4" max; beam depth 8" min. standard, 6-3/8"-8-5/8" with 1st extension, 8-3/4"-11" with 2nd extension. See Optional Price section for extension pricing.

① Occurs on smallest beam size only. On larger beams, it is increased by the difference in flange width.

② Clearance shown is between lug and wheel tread.

③ Dimension increases 3" when hoist is equipped with screw type limit switch.

* Estimated wheel load per one (1) wheel. Includes live and dead load impacts.

† For a Y80 add a "Y" prefix.

**Single
Reeved**

5 Ton

ELECTRIC WIRE ROPE

Y80 - 800 Series

MOTOR DRIVEN TROLLEY

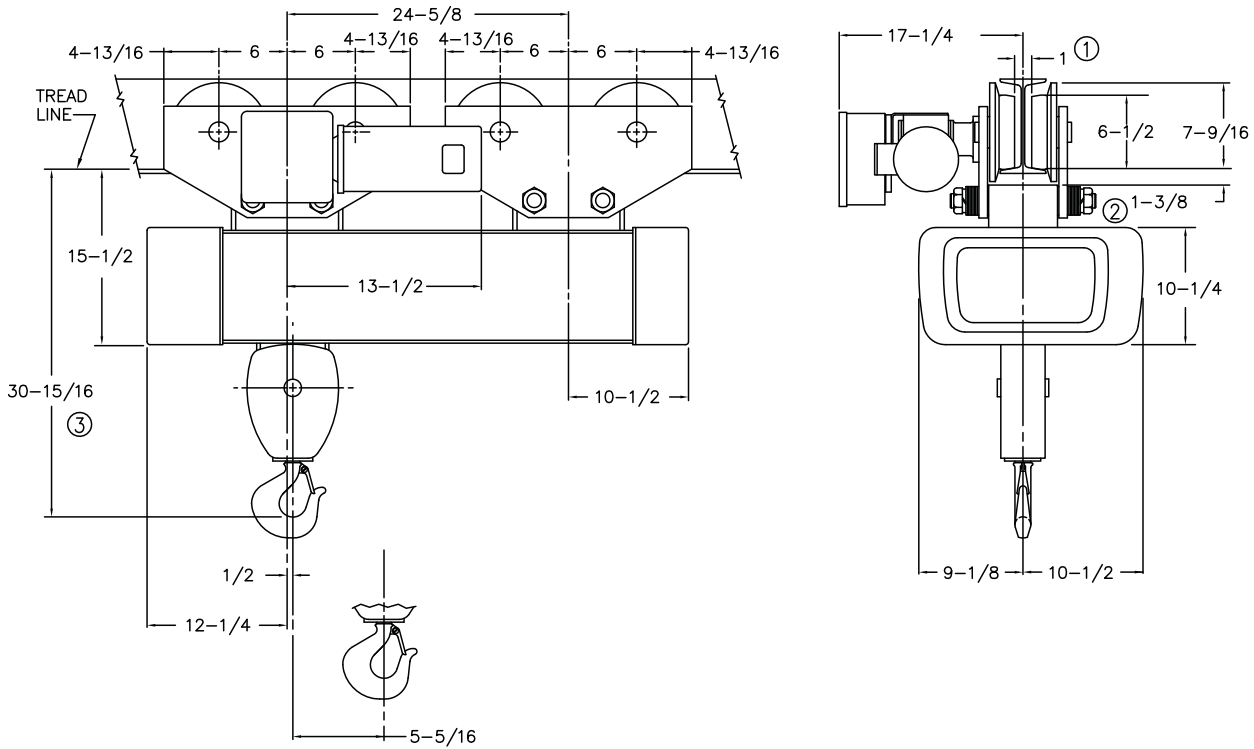

MINIMUM RADIUS: Straight Track ④

CATALOG NUMBER	HOIST			TROLLEY		WEIGHT (LBS)	ESTIMATED WHEEL LOAD*		
	MAX LIFT (FT)	HOIST SPEED (FPM)	HP	ROPE NO & DIA	SPEED (FPM)		HP	HIGH HOOK (LBS)	LOW HOOK (LBS)
†80M05-030S10-1	30	10	4	6-5/16	50	1/2	850	2992	2359
†80M05-030S10-2	30	10/5	4/2	6-5/16	50	1/2	875	2996	2363

Weights shown are for standard hoists listed. For approximate shipping weights, add 110 lbs. to the net weight given. Consult factory for weights of special hoists. Dimensions shown are in inches unless otherwise noted.

When used on smallest I-beam size, beam must be free of all obstructions, such as clips, suspension bolts, and nuts. Trolleys for wide flange beams refer to Optional Equipment.

Trolley beam size range – beam flange width 4" min., 6-1/4" max; beam depth 8" min. standard, 6-3/8"-8-5/8" with 1st extension, 8-3/4"-11" with 2nd extension. See Optional Price section for extension pricing.

- ① Occurs on smallest beam size only. On larger beams, it is increased by the difference in flange width.
- ② Clearance shown is between lug and wheel tread.
- ③ Dimension increases 3" when hoist is equipped with screw type limit switch.
- ④ Can negotiate curves with addition of swivel trolley from the option pricing section. Headroom increases by 4-5/8".

* Estimated wheel load per one (1) wheel. Includes live and dead load impacts.

† For a Y80 add a "Y" prefix.

Standard Features

Dimensions & Specifications

ELECTRIC WIRE ROPE

Y80 - 800 Series

Double Reeved Electric Hoists with Motor Driven Trolleys

Feature	1/2 Ton	1 Ton	2 Ton
Service Class	H-4	H-4	H-4
Reeved	4 PD - 3/16"	4 PD - 3/16"	4 PD - 1/4'
Hoist Gearing	Triple reduction Helical/Spur	Triple reduction Helical/Spur	Triple reduction Helical/Spur
Hook Assembly	Bearing Thrust Washer 360 degree rotate	Bearing Thrust Washer 360 degree rotate	Bearing Thrust Washer 360 degree rotate
Hoist Motor	30-minute rated TENV	30-minute rated TENV	30-minute rated TENV
Hoist Motor Brake (AC)	100% Torque disc	100% Torque disc	100% Torque disc
Load Brake	Weston type Roller Ratchet	Weston type Roller Ratchet	Weston type Roller Ratchet
Hoist Control	1-speed	1-speed	1-speed
Control Circuit voltage	115 Volts	115 Volts	115 Volts
Hoist Limit Switch	Upper block control circuit	Upper block control circuit	Upper block control circuit
Rope Drum Diameter	7-1/2"	7-1/2"	7-1/2"
Rope Drum Material	Cast Iron	Cast Iron	Cast Iron
Sheave Diameter	5"	5"	5"
Sheave Material	Steel	Steel	Steel
Trolley Gearing	Worm	Worm	Worm
Trolley Motor	30-minute rated TENV	30-minute rated TENV	30-minute rated TENV
Trolley Brake	Optional AC Disc	Optional AC Disc	Optional AC Disc
Trolley Control	1-speed	1-speed	1-speed
Wheels	4"	4"	4"
Bumpers	Optional Rubber	Optional Rubber	Optional Rubber
Bearings	Anti-friction	Anti-friction	Anti-friction
Motor TAS	Standard	Standard	Standard
Control Enclosure	NEMA 1	NEMA 1	NEMA 1

Double Reeved

1/2 Ton

ELECTRIC WIRE ROPE

Y80 - 800 Series

MOTOR DRIVEN TROLLEY

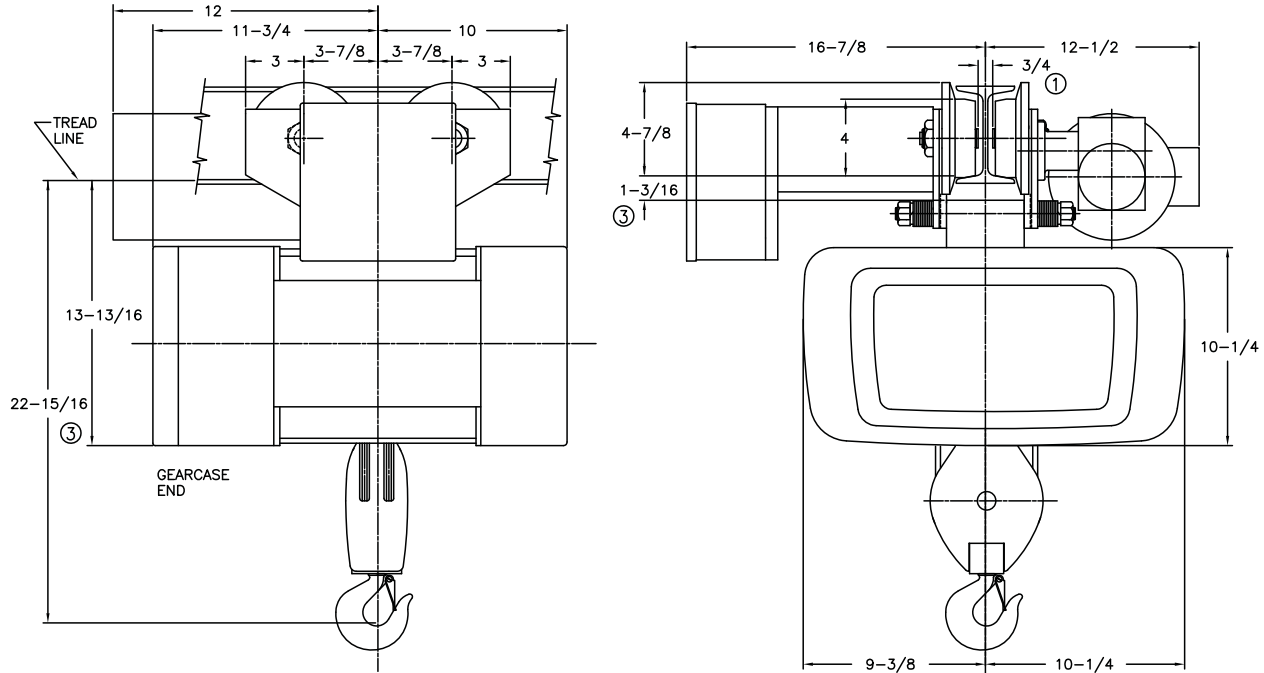

MINIMUM STANDARD RADIUS: 3'-6"

CATALOG NUMBER	HOIST				TROLLEY		WEIGHT (LBS)	ESTIMATED WHEEL LOAD* (LBS)
	MAX LIFT (FT)	HOIST SPEED (FPM)	HP	ROPE NO & DIA	SPEED (FPM)	HP		
†80M.5-018D18-1	18	18	1	4/2-3/16	75	1/4	260	359
†80M.5-018D18-2	18	18/6	1/33	4/2-3/16	75	1/4	300	370
†80M.5-018D35-1	18	35	2	4/2-3/16	75	1/4	260	362
†80M.5-018D35-2	18	35/11.7	2/.66	4/2-3/16	75	1/4	300	373
†80M.5-018D50-1	18	50	4	4/2-3/16	75	1/4	291	390
†80M.5-018D50-2	18	50/16.6	3/1	4/2-3/16	75	1/4	331	401

Weights shown are for standard hoists listed. For approximate shipping weights, add 110 lbs. to the net weight given. Consult factory for weights of special hoists. Dimensions shown are in inches unless otherwise noted.

When used on smallest I-beam size, beam must be free of all obstructions, such as clips, suspension bolts, and nuts. Trolleys for wide flange beams refer to Optional Equipment.

Trolley beam size range – beam flange width 3" min., 5" max; beam depth 6" min. standard, 5-1/8"-7-1/4" with 1st extension, 7-1/2"-9-1/8" with 2nd extension. See Optional Price section for extension pricing.

① Occurs on smallest beam size only. On larger beams, it is increased by the difference in flange width.

② Clearance shown is between lug and wheel tread.

③ Dimension increases 3" when hoist is equipped with screw type limit switch.

* Estimated wheel load per one (1) wheel. Includes live and dead load impacts.

† For a Y80 add a "Y" prefix.

Double Reeved

1/2 Ton

ELECTRIC WIRE ROPE

Y80 - 800 Series

MOTOR DRIVEN TROLLEY

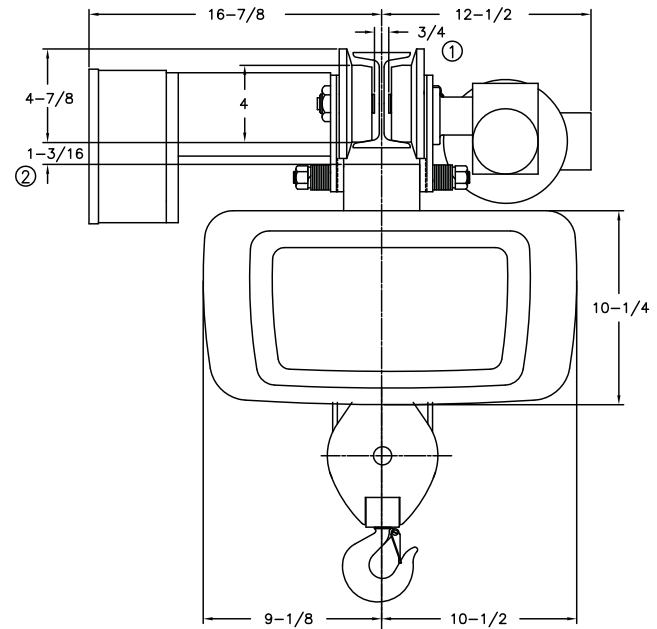
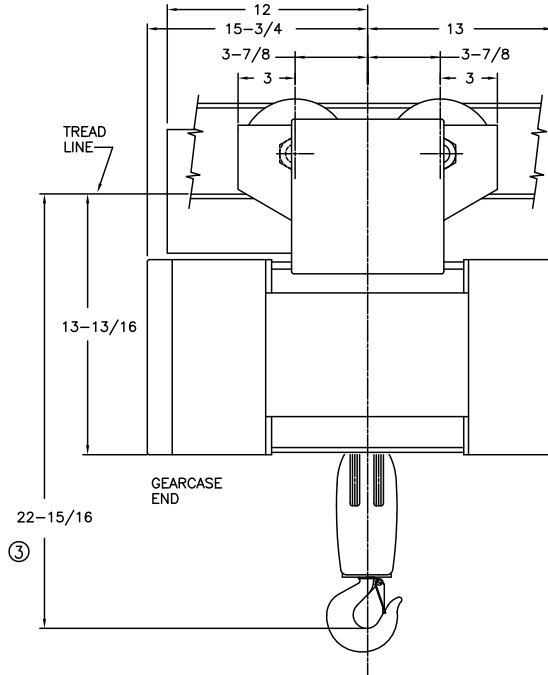

MINIMUM STANDARD RADIUS: 3'-6"

CATALOG NUMBER	HOIST				TROLLEY		WEIGHT (LBS)	ESTIMATED WHEEL LOAD* (LBS)
	MAX LIFT (FT)	HOIST SPEED (FPM)	HP	ROPE NO & DIA	SPEED (FPM)	HP		
†80M.5-034D18-1	34	18	1	4/2-3/16	50	1/4	385	393
†80M.5-034D18-2	34	18/6	1/33	4/2-3/16	50	1/4	420	403
†80M.5-034D35-1	34	35	2	4/2-3/16	50	1/4	385	396
†80M.5-034D35-2	34	35/11.7	2/66	4/2-3/16	50	1/4	420	406
†80M.5-034D50-1	34	50	4	4/2-3/16	50	1/4	416	424
†80M.5-034D50-2	34	50/16.6	3/1	4/2-3/16	50	1/4	451	434

Weights shown are for standard hoists listed. For approximate shipping weights, add 110 lbs. to the net weight given. Consult factory for weights of special hoists. Dimensions shown are in inches unless otherwise noted.

When used on smallest I-beam size, beam must be free of all obstructions, such as clips, suspension bolts, and nuts. Trolleys for wide flange beams refer to Optional Equipment.

Trolley beam size range – beam flange width 3" min., 5" max; beam depth 6" min. standard, 5-1/8"-7-1/4" with 1st extension, 7-1/2"-9-1/8" with 2nd extension. See Optional Price section for extension pricing.

① Occurs on smallest beam size only. On larger beams, it is increased by the difference in flange width.

② Clearance shown is between lug and wheel tread.

③ Dimension increases 3" when hoist is equipped with screw type limit switch.

* Estimated wheel load per one (1) wheel. Includes live and dead load impacts.

† For a Y80 add a "Y" prefix.

Double Reeved

1/2 Ton

ELECTRIC WIRE ROPE

Y80 - 800 Series

MOTOR DRIVEN TROLLEY

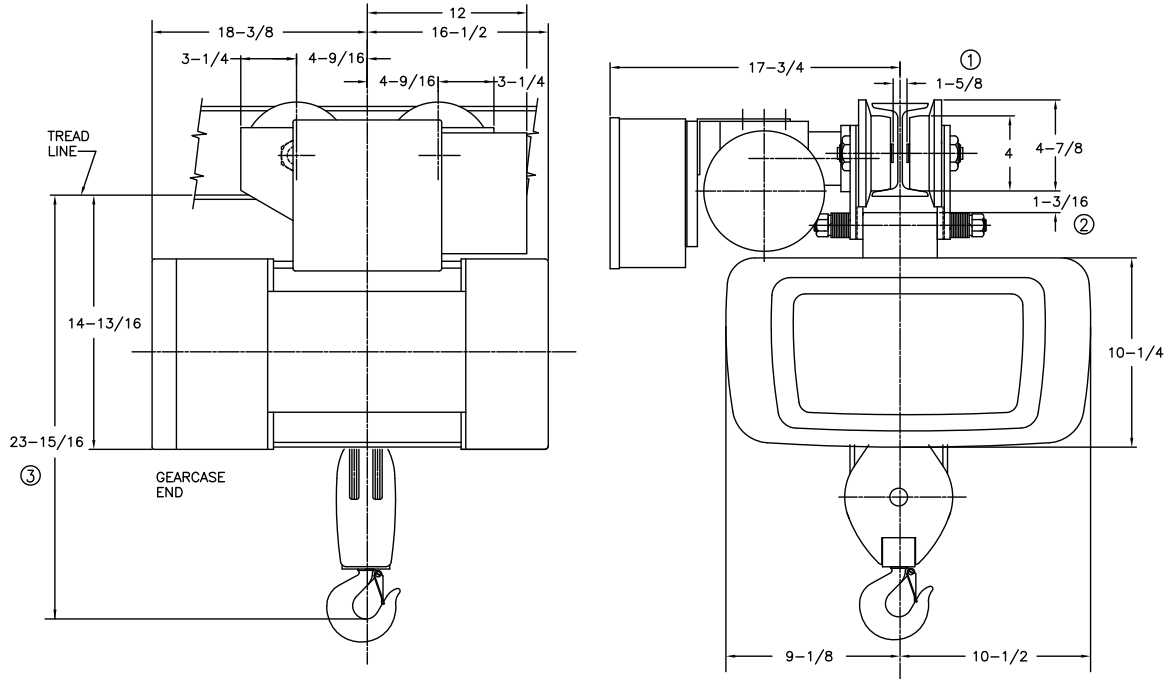

MINIMUM STANDARD RADIUS: 5'-0"

CATALOG NUMBER	HOIST				TROLLEY		WEIGHT (LBS)	ESTIMATED WHEEL LOAD* (LBS)
	MAX LIFT (FT)	HOIST SPEED (FPM)	HP	ROPE NO & DIA	SPEED (FPM)	HP		
†80M.5-047D18-1	47	18	1	4/2-3/16	50	1/4	385	393
†80M.5-047D18-2	47	18/6	1/.33	4/2-3/16	50	1/4	420	403
†80M.5-047D35-1	47	35	2	4/2-3/16	50	1/4	385	396
†80M.5-047D35-2	47	35/11.7	2/.66	4/2-3/16	50	1/4	420	406
†80M.5-047D50-1	47	50	4	4/2-3/16	50	1/4	591	473
†80M.5-047D50-2	47	50/16.6	3/1	4/2-3/16	50	1/4	626	482

Weights shown are for standard hoists listed. For approximate shipping weights, add 110 lbs. to the net weight given. Consult factory for weights of special hoists. Dimensions shown are in inches unless otherwise noted.

When used on smallest I-beam size, beam must be free of all obstructions, such as clips, suspension bolts, and nuts. Trolleys for wide flange beams refer to Optional Equipment.

Trolley beam size range – beam flange width 4" min., 6-1/4" max; beam depth 6" min. standard, 6-3/8"-8-5/8" with 1st extension, 8-3/4"-11" with 2nd extension. See Optional Price section for extension pricing.

① Occurs on smallest beam size only. On larger beams, it is increased by the difference in flange width.

② Clearance shown is between lug and wheel tread.

③ Dimension increases 3" when hoist is equipped with screw type limit switch.

* Estimated wheel load per one (1) wheel. Includes live and dead load impacts.

† For a Y80 add a "Y" prefix.

Double Reeved

1 Ton

ELECTRIC WIRE ROPE

Y80 - 800 Series

MOTOR DRIVEN TROLLEY

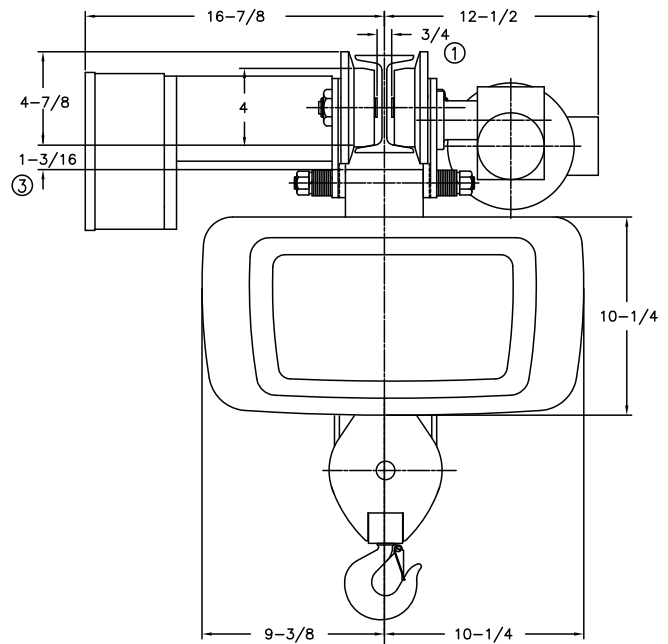
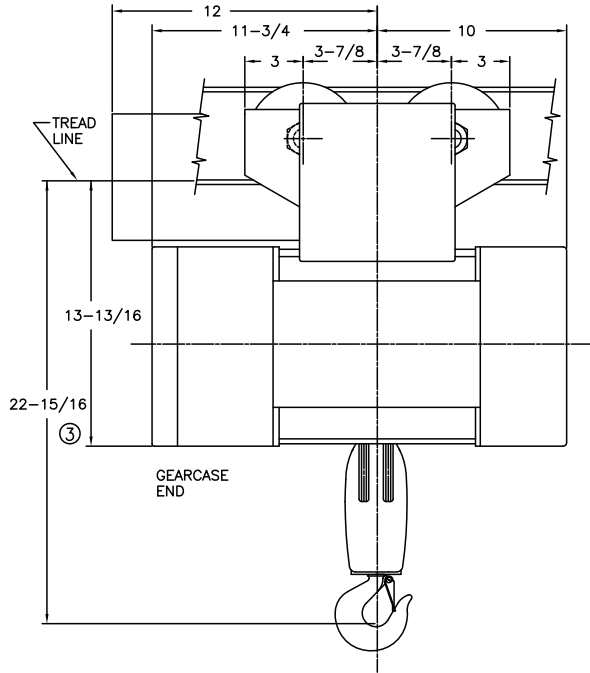

MINIMUM STANDARD RADIUS: 3'-6"

CATALOG NUMBER	HOIST				TROLLEY		WEIGHT (LBS)	ESTIMATED WHEEL LOAD* (LBS)
	MAX LIFT (FT)	HOIST SPEED (FPM)	HP	ROPE NO & DIA	SPEED (FPM)	HP		
†80M01-018D18-1	18	18	2	4/2-3/16	75	1/4	266	648
†80M01-018D18-2	18	18/6	2/.66	4/2-3/16	75	1/4	301	658
†80M01-018D28-1	18	28	2	4/2-3/16	75	1/4	291	660
†80M01-018D28-2	18	28/9.4	2/.66	4/2-3/16	75	1/4	301	663
†80M01-018D50-1	18	50	4	4/2-3/16	75	1/4	291	700
†80M01-018D50-2	18	50/25	4/2	4/2-3/16	75	1/4	301	703

Weights shown are for standard hoists listed. For approximate shipping weights, add 110 lbs. to the net weight given. Consult factory for weights of special hoists. Dimensions shown are in inches unless otherwise noted.

When used on smallest I-beam size, beam must be free of all obstructions, such as clips, suspension bolts, and nuts. Trolleys for wide flange beams refer to Optional Equipment.

Trolley beam size range – beam flange width 3" min., 5" max; beam depth 6" min. standard, 5-1/8"-7-1/4" with 1st extension, 7-1/2"-9-1/8" with 2nd extension. See Optional Price section for extension pricing.

① Occurs on smallest beam size only. On larger beams, it is increased by the difference in flange width.

② Clearance shown is between lug and wheel tread.

③ Dimension increases 3" when hoist is equipped with screw type limit switch.

* Estimated wheel load per one (1) wheel. Includes live and dead load impacts.

† For a Y80 add a "Y" prefix.

Double Reeved

1 Ton

ELECTRIC WIRE ROPE

Y80 - 800 Series

MOTOR DRIVEN TROLLEY

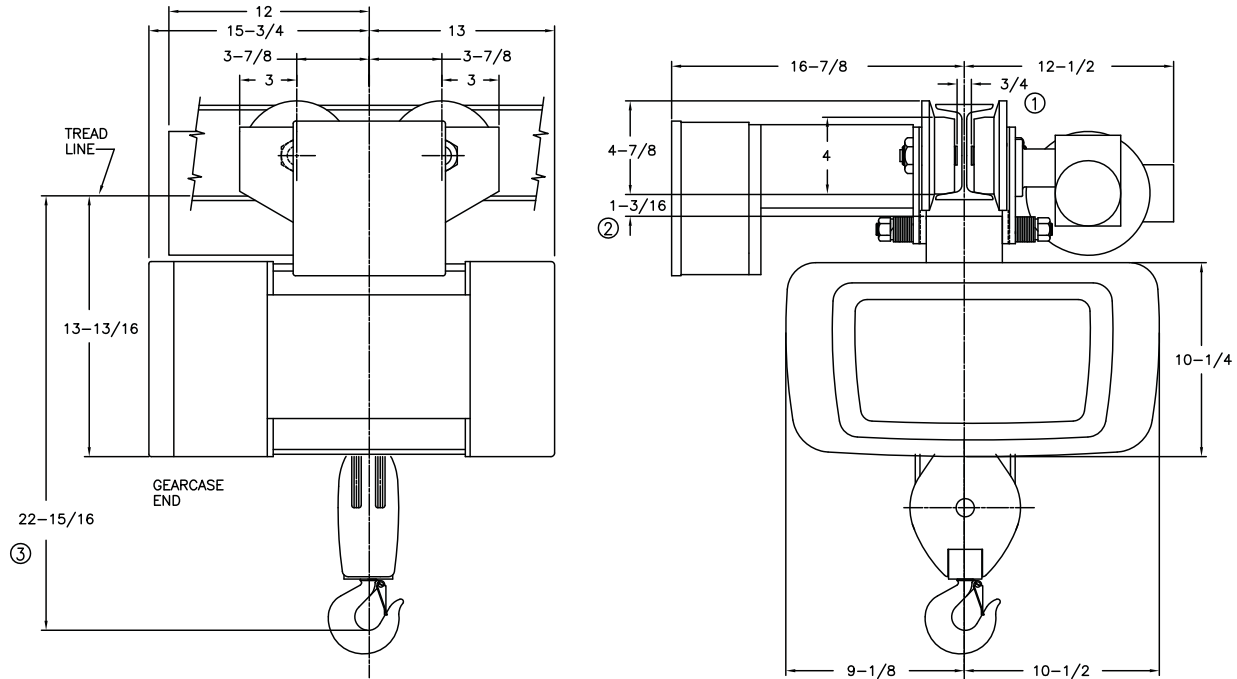

MINIMUM STANDARD RADIUS: 3'-6"

CATALOG NUMBER	HOIST				TROLLEY		WEIGHT (LBS)	ESTIMATED WHEEL LOAD* (LBS)
	MAX LIFT (FT)	HOIST SPEED (FPM)	HP	ROPE NO & DIA	SPEED (FPM)	HP		
†80M01-034D18-1	34	18	2	4/2-3/16	50	1/4	385	681
†80M01-034D18-2	34	18/6	2/.66	4/2-3/16	50	1/4	420	691
†80M01-034D28-1	34	28	2	4/2-3/16	50	1/4	415	694
†80M01-034D28-2	34	28/9.4	2/.66	4/2-3/16	50	1/4	420	696
†80M01-034D50-1	34	50	4	4/2-3/16	50	1/4	415	734
†80M01-034D50-2	34	50/25	4/2	4/2-3/16	50	1/4	420	736

Weights shown are for standard hoists listed. For approximate shipping weights, add 110 lbs. to the net weight given. Consult factory for weights of special hoists. Dimensions shown are in inches unless otherwise noted.

When used on smallest I-beam size, beam must be free of all obstructions, such as clips, suspension bolts, and nuts. Trolleys for wide flange beams refer to Optional Equipment.

Trolley beam size range – beam flange width 3" min., 5" max; beam depth 6" min. standard, 5-1/8"-7-1/4" with 1st extension, 7-1/2"-9-1/8" with 2nd extension. See Optional Price section for extension pricing.

① Occurs on smallest beam size only. On larger beams, it is increased by the difference in flange width.

② Clearance shown is between lug and wheel tread.

③ Dimension increases 3" when hoist is equipped with screw type limit switch.

* Estimated wheel load per one (1) wheel. Includes live and dead load impacts.

† For a Y80 add a "Y" prefix.

Double Reeved

1 Ton

ELECTRIC WIRE ROPE

Y80 - 800 Series

MOTOR DRIVEN TROLLEY

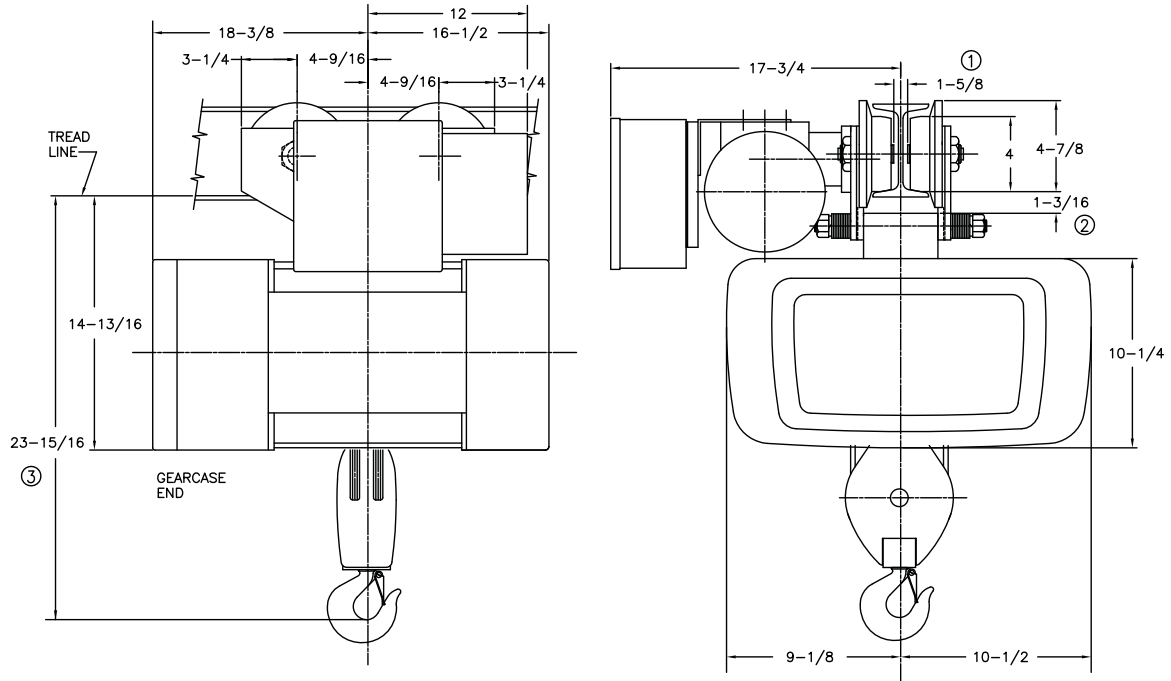

MINIMUM STANDARD RADIUS: 5'-0"

CATALOG NUMBER	HOIST				TROLLEY		WEIGHT (LBS)	ESTIMATED WHEEL LOAD* (LBS)
	MAX LIFT (FT)	HOIST SPEED (FPM)	HP	ROPE NO & DIA	SPEED (FPM)	HP		
†80M01-047D18-1	47	18	2	4/2-3/16	50	1/4	495	711
†80M01-047D18-2	47	18/6	2/.66	4/2-3/16	50	1/4	540	724
†80M01-047D28-1	47	28	2	4/2-3/16	50	1/4	525	724
†80M01-047D28-2	47	28/9.4	2/.66	4/2-3/16	50	1/4	540	729
†80M01-047D50-1	47	50	4	4/2-3/16	50	1/4	525	764
†80M01-047D50-2	47	50/25	4/2	4/2-3/16	50	1/4	540	769

Weights shown are for standard hoists listed. For approximate shipping weights, add 110 lbs. to the net weight given. Consult factory for weights of special hoists. Dimensions shown are in inches unless otherwise noted.

When used on smallest I-beam size, beam must be free of all obstructions, such as clips, suspension bolts, and nuts. Trolleys for wide flange beams refer to Optional Equipment.

Trolley beam size range – beam flange width 3-5/8" min., 6" max; beam depth 6" min. standard, 6-1/4"-8-5/8" with 1st extension, 8-3/4"-11" with 2nd extension. See Optional Price section for extension pricing.

① Occurs on smallest beam size only. On larger beams, it is increased by the difference in flange width.

② Clearance shown is between lug and wheel tread.

③ Dimension increases 3" when hoist is equipped with screw type limit switch.

* Estimated wheel load per one (1) wheel. Includes live and dead load impacts.

† For a Y80 add a "Y" prefix.

Double Reeved

2 Ton

ELECTRIC WIRE ROPE

Y80 - 800 Series

MOTOR DRIVEN TROLLEY

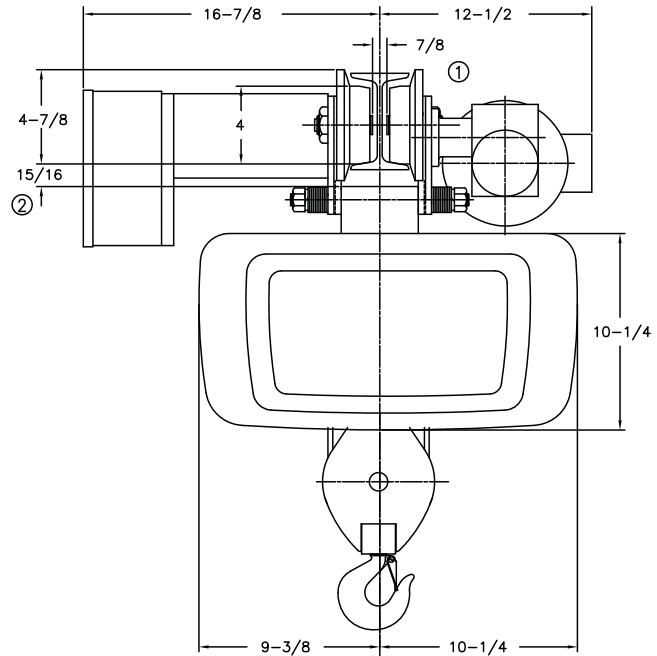
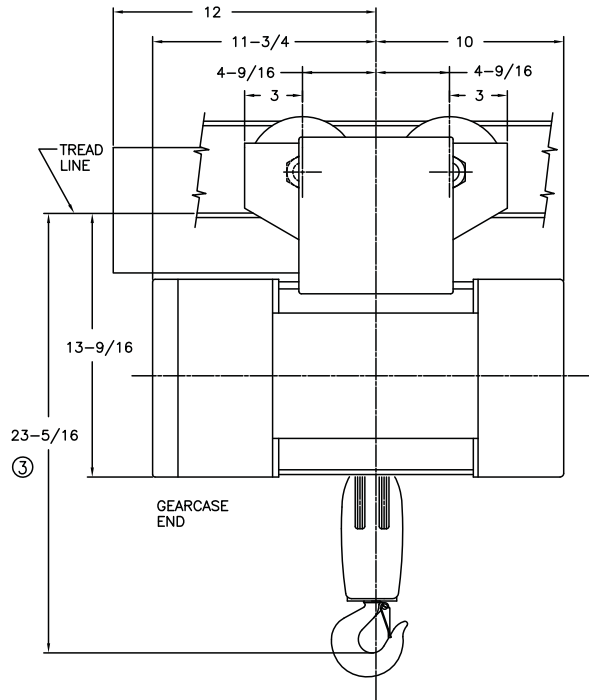

MINIMUM STANDARD RADIUS: 5'-0"

CATALOG NUMBER	HOIST				TROLLEY		WEIGHT (LBS)	ESTIMATED WHEEL LOAD* (LBS)
	MAX LIFT (FT)	HOIST SPEED (FPM)	HP	ROPE NO & DIA	SPEED (FPM)	HP		
†80M02-014D14-1	14	14	2	4/2-1/4	60	1/4	385	1256
†80M02-014D14-2	14	14/4.66	2/66	4/2-1/4	60	1/4	400	1260
†80M02-014D28-1	14	28	4	4/2-1/4	60	1/4	385	1256
†80M02-014D28-2	14	28/14	4/2	4/2-1/4	60	1/4	400	1260

Weights shown are for standard hoists listed. For approximate shipping weights, add 110 lbs. to the net weight given. Consult factory for weights of special hoists. Dimensions shown are in inches unless otherwise noted,

When used on smallest I-beam size, beam must be free of all obstructions, such as clips, suspension bolts, and nuts. Trolleys for wide flange beams refer to Optional Equipment.

Trolley beam size range – beam flange width 3-5/8" min., 6" max; beam depth 6" min. standard, 6-1/4"-8-5/8" with 1st extension, 8-7/8"-11-1/4" with 2nd extension. See Optional Price section for extension pricing.

① Occurs on smallest beam size only. On larger beams, it is increased by the difference in flange width.

② Clearance shown is between lug and wheel tread.

③ Dimension increases 3" when hoist is equipped with screw type limit switch.

* Estimated wheel load per one (1) wheel. Includes live and dead load impacts.

† For a Y80 add a "Y" prefix.

**Double
Reeved**

2 Ton

ELECTRIC WIRE ROPE

Y80 - 800 Series

MOTOR DRIVEN TROLLEY

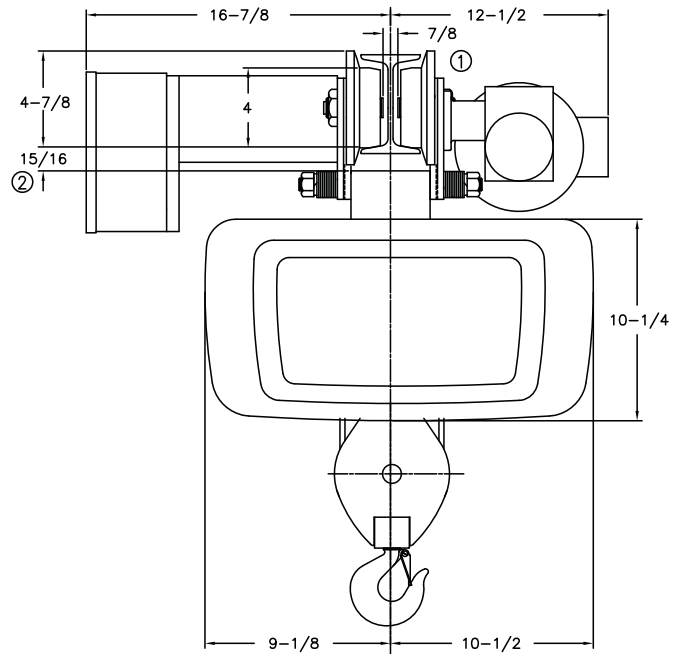
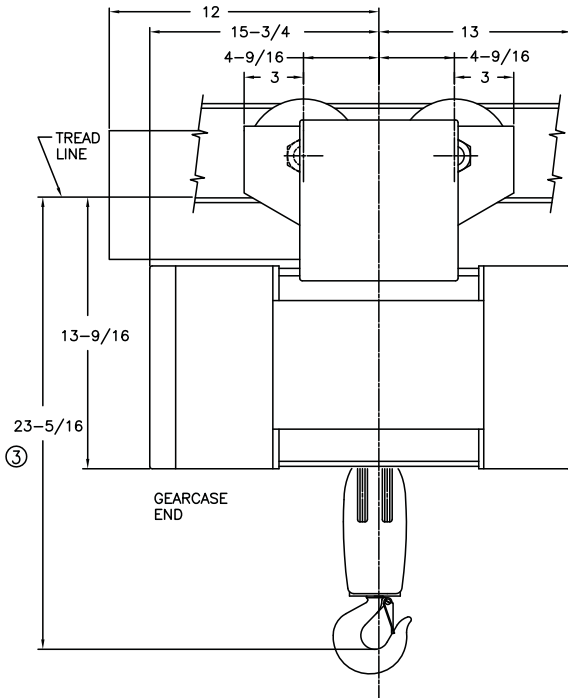

MINIMUM STANDARD RADIUS: 5'-0"

CATALOG NUMBER	HOIST				TROLLEY		WEIGHT (LBS)	ESTIMATED WHEEL LOAD* (LBS)
	MAX LIFT (FT)	HOIST SPEED (FPM)	HP	ROPE NO & DIA	SPEED (FPM)	HP		
+80M02-025D14-1	25	14	2	4/2-1/4	60	1/4	410	1263
+80M02-025D14-2	25	14/4.66	2/.66	4/2-1/4	60	1/4	425	1267
+80M02-025D28-1	25	28	4	4/2-1/4	60	1/4	410	1263
+80M02-025D28-2	25	28/14	4/2	4/2-1/4	60	1/4	425	1267

Weights shown are for standard hoists listed. For approximate shipping weights, add 110 lbs. to the net weight given. Consult factory for weights of special hoists. Dimensions shown are in inches unless otherwise noted.

When used on smallest I-beam size, beam must be free of all obstructions, such as clips, suspension bolts, and nuts. Trolleys for wide flange beams refer to Optional Equipment.

Trolley beam size range – beam flange width 3-5/8" min., 6" max; beam depth 6" min. standard, 6-1/4"-8-5/8" with 1st extension, 8-7/8"-11-1/4" with 2nd extension. See Optional Price section for extension pricing.

① Occurs on smallest beam size only. On larger beams, it is increased by the difference in flange width.

② Clearance shown is between lug and wheel tread.

③ Dimension increases 3" when hoist is equipped with screw type limit switch.

* Estimated wheel load per one (1) wheel. Includes live and dead load impacts.

† For a Y80 add a "Y" prefix.

Double
Reeved

2 Ton

ELECTRIC WIRE ROPE

Y80 - 800 Series

MOTOR DRIVEN TROLLEY

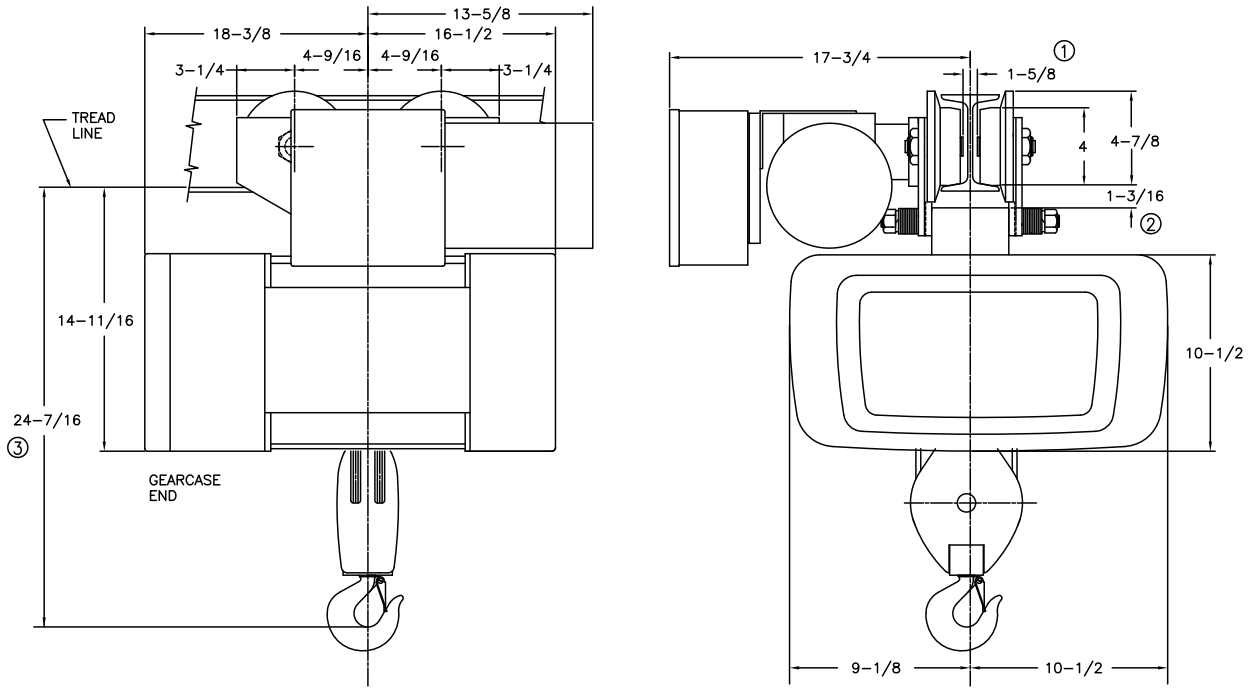

MINIMUM STANDARD RADIUS: 5'-0"

CATALOG NUMBER	HOIST				TROLLEY		WEIGHT (LBS)	ESTIMATED WHEEL LOAD* (LBS)
	MAX LIFT (FT)	HOIST SPEED (FPM)	HP	ROPE NO & DIA	SPEED (FPM)	HP		
†80M02-036D14-1	36	14	2	4/2-1/4	50	1/4	525	1294
†80M02-036D14-2	36	14/4.66	2/.66	4/2-1/4	50	1/4	540	1299
†80M02-036D28-1	36	28	4	4/2-1/4	50	1/4	525	1294
†80M02-036D28-2	36	28/14	4/2	4/2-1/4	50	1/4	540	1299

Weights shown are for standard hoists listed. For approximate shipping weights, add 110 lbs. to the net weight given. Consult factory for weights of special hoists. Dimensions shown are in inches unless otherwise noted.

When used on smallest I-beam size, beam must be free of all obstructions, such as clips, suspension bolts, and nuts. Trolleys for wide flange beams refer to Optional Equipment.

Trolley beam size range – beam flange width 4" min., 6-1/4" max; beam depth 6" min. standard, 6-3/8"-8-5/8" with 1st extension, 8-3/4"-11" with 2nd extension. See Optional Price section for extension pricing.

① Occurs on smallest beam size only. On larger beams, it is increased by the difference in flange width.

② Clearance shown is between lug and wheel tread.

③ Dimension increases 3" when hoist is equipped with screw type limit switch.

* Estimated wheel load per one (1) wheel. Includes live and dead load impacts.

† For a Y80 add a "Y" prefix.

Standard Features

Dimensions & Specifications

AIR WIRE ROPE

Y80 - 800 Series

Single Reeved Air Hoists with Motor Driven Trolleys

Feature	1 Ton	2 Ton	3 Ton	5 Ton
Service Class	H-4	H-4	H-4	H-4
Reeved	2 PS - 1/4"	2 PS - 5/16"	4 PS - 5/16"	6 PS - 5/16"
Hoist Gearing	Triple reduction Helical/Spur	Triple reduction Helical/Spur	Triple reduction Helical/Spur	Triple reduction Helical/Spur
Hook Assembly	Bearing Thrust Washer 360 degree rotate	Bearing Thrust Washer 360 degree rotate	Bearing-mounted 360 degree rotate	Bearing-mounted 360 degree rotate
Hoist Motor	Vane-type Air Motor	Vane-type Air Motor	Vane-type Air Motor	Vane-type Air Motor
Hoist Motor Brake	Optional Air-Operated	Optional Air-Operated	Optional Air-Operated	Optional Air-Operated
Load Brake	Weston type Roller Ratchet	Weston type Roller Ratchet	Weston type Roller Ratchet	Weston type Roller Ratchet
Hoist Control	Variable Speed	Variable Speed	Variable Speed	Variable Speed
Hoist Limit Switch	Upper block control circuit	Upper block control circuit	Upper block control circuit	Upper block control circuit
Rope Drum Diameter	7-1/2"	7-1/2"	7-1/2"	7-1/2"
Rope Drum Material	Cast Iron	Cast Iron	Cast Iron	Cast Iron
Sheave Diameter	5"	6"	6"	6"
Sheave Material	Steel	Steel	Steel	Steel
Trolley Gearing	Worm	Worm	Worm	Worm
Trolley Motor	Vane-type Air Motor	Vane-type Air Motor	Vane-type Air Motor	Vane-type Air Motor
Trolley Control	Variable Speed	Variable Speed	Variable Speed	Variable Speed
Wheels	4"	4"	4" for 45' lift 6-1/2" for 30' lift	6-1/2"
Bumpers	Optional Rubber	Optional Rubber	Optional Rubber	Optional Rubber
Bearings	Anti-friction	Anti-friction	Anti-friction	Anti-friction

Air Motor Data: Hoist = 90 PSI @ 110-125 Scfm - 3/4" NPT air inlet

Single Reeved

1 Ton

AIR WIRE ROPE

Y80 - 800 Series

MOTOR DRIVEN TROLLEY

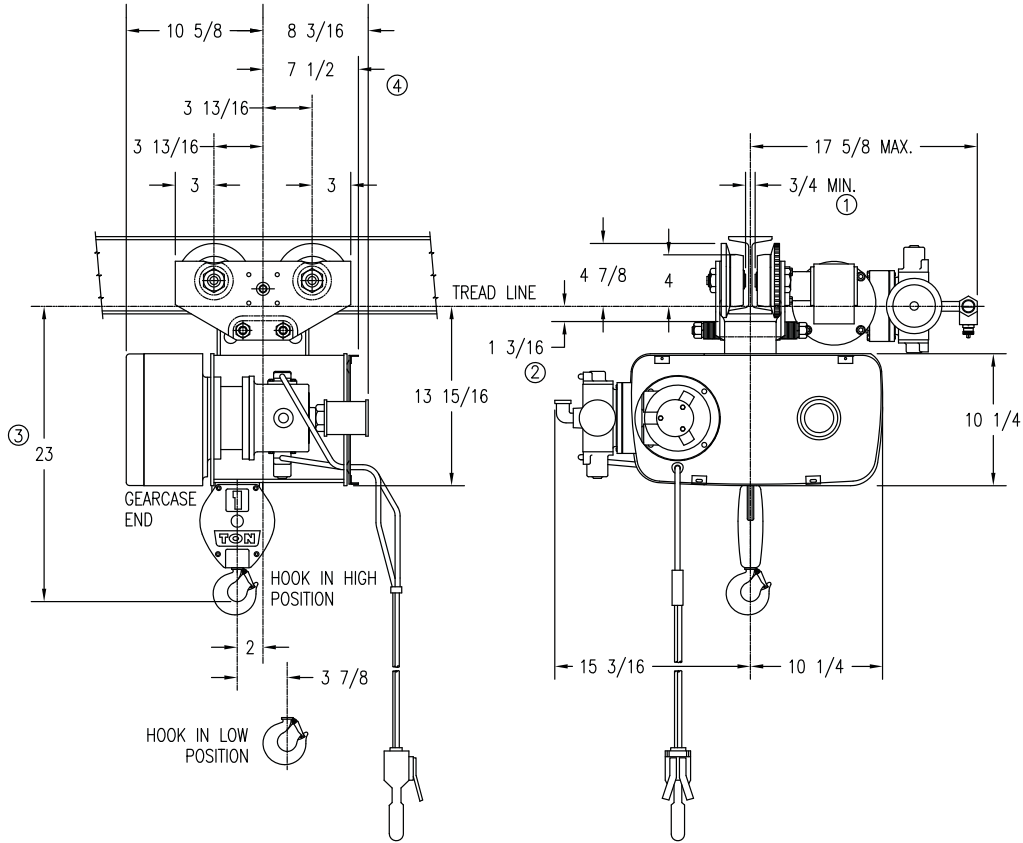

MINIMUM STANDARD RADIUS: 4'-0", FOR SMALLER RADIUS CONTACT FACTORY

CATALOG NUMBER	HOIST				TROLLEY		WEIGHT (LBS)	ESTIMATED WHEEL LOAD*	
	MAX LIFT (FT)	HOIST SPEED (FPM)	MOTOR SIZE	ROPE NO & DIA	SPEED (FPM)	MOTOR SIZE		HIGH HOOK (LBS)	LOW HOOK (LBS)
†80M01-025S33-A	25	33	A	2-1/4	75	A	310	968	950

Weights shown are for standard hoists listed. For approximate shipping weights, add 110 lbs. to the net weight given. Consult factory for weights of special hoists. Dimensions shown are in inches unless otherwise noted.

When used on smallest I-beam size, beam must be free of all obstructions, such as clips, suspension bolts, and nuts. Trolleys for wide flange beams refer to Optional Equipment.

Trolley beam size range – beam flange width 3" min., 5" max; beam depth 6" min. standard, 5-1/8"-7-1/4" with 1st extension, 7-1/2"-9-1/8" with 2nd extension. See Optional Price section for extension pricing.

① Occurs on smallest beam size only. On larger beams, it is increased by the difference in flange width.

② Clearance shown is between lug and wheel tread.

③ Dimension increases 3" when hoist is equipped with screw type limit switch.

④ Dimension increases 4" when hoist is equipped with screw type limit switch.

* Estimated wheel load per one (1) wheel. Includes live and dead load impacts.

† For a Y80 add a "Y" prefix.

**Single
Reeved**

1 Ton

AIR WIRE ROPE

Y80 - 800 Series

MOTOR DRIVEN TROLLEY

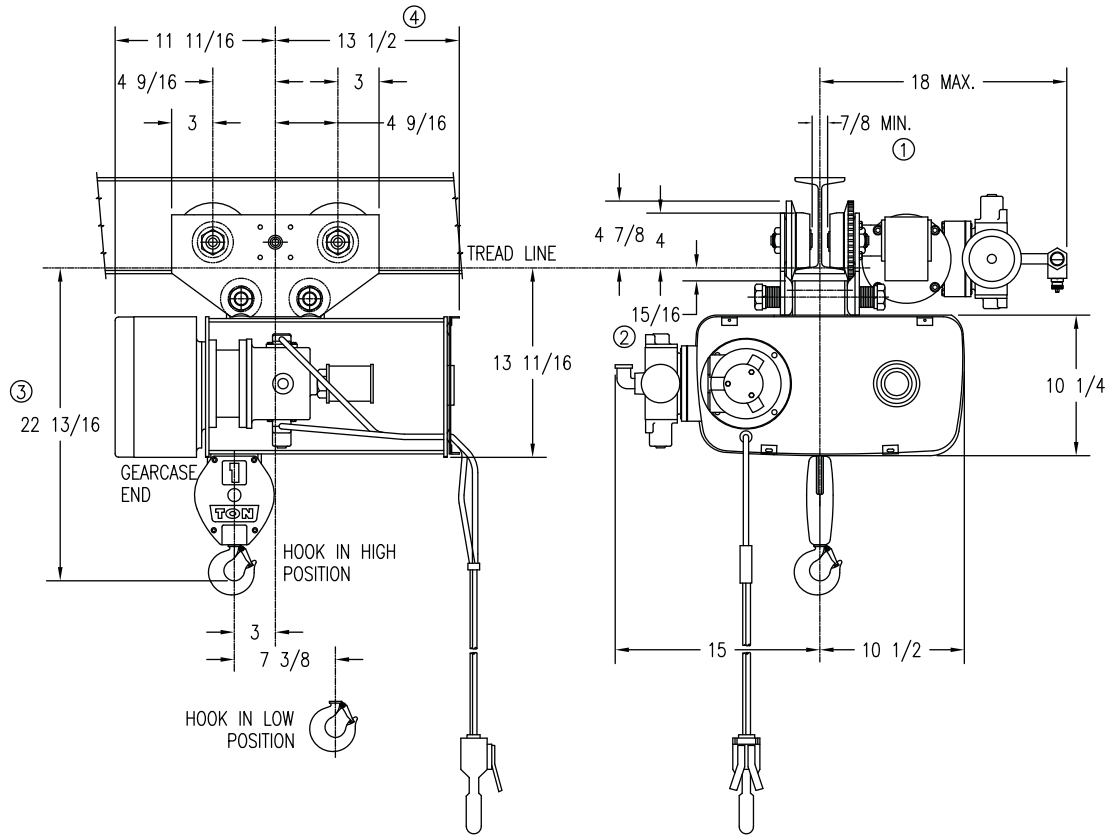

MINIMUM STANDARD RADIUS: 5'-0", FOR SMALLER RADIUS CONTACT FACTORY

CATALOG NUMBER	HOIST				TROLLEY		WEIGHT (LBS)	ESTIMATED WHEEL LOAD*	
	MAX LIFT (FT)	HOIST SPEED (FPM)	MOTOR SIZE	ROPE NO & DIA	SPEED (FPM)	MOTOR SIZE		HIGH HOOK (LBS)	LOW HOOK (LBS)
†80M01-050S33-A	50	33	A	2-1/4	60	A	415	1074	1248

Weights shown are for standard hoists listed. For approximate shipping weights, add 110 lbs. to the net weight given. Consult factory for weights of special hoists. Dimensions shown are in inches unless otherwise noted.

When used on smallest I-beam size, beam must be free of all obstructions, such as clips, suspension bolts, and nuts. Trolleys for wide flange beams refer to Optional Equipment.

Trolley beam size range – beam flange width 3-5/8" min., 6" max; beam depth 7" min. standard, 6-1/4"-8-5/8" with 1st extension, 8-7/8"-11-1/4" with 2nd extension. See Optional Price section for extension pricing.

① Occurs on smallest beam size only. On larger beams, it is increased by the difference in flange width.

② Clearance shown is between lug and wheel tread.

③ Dimension increases 3" when hoist is equipped with screw type limit switch.

④ Dimension increases 4" when hoist is equipped with screw type limit switch.

* Estimated wheel load per one (1) wheel. Includes live and dead load impacts.

† For a Y80 add a "Y" prefix.

Single Reeved

2 Ton

AIR WIRE ROPE

Y80 - 800 Series

MOTOR DRIVEN TROLLEY

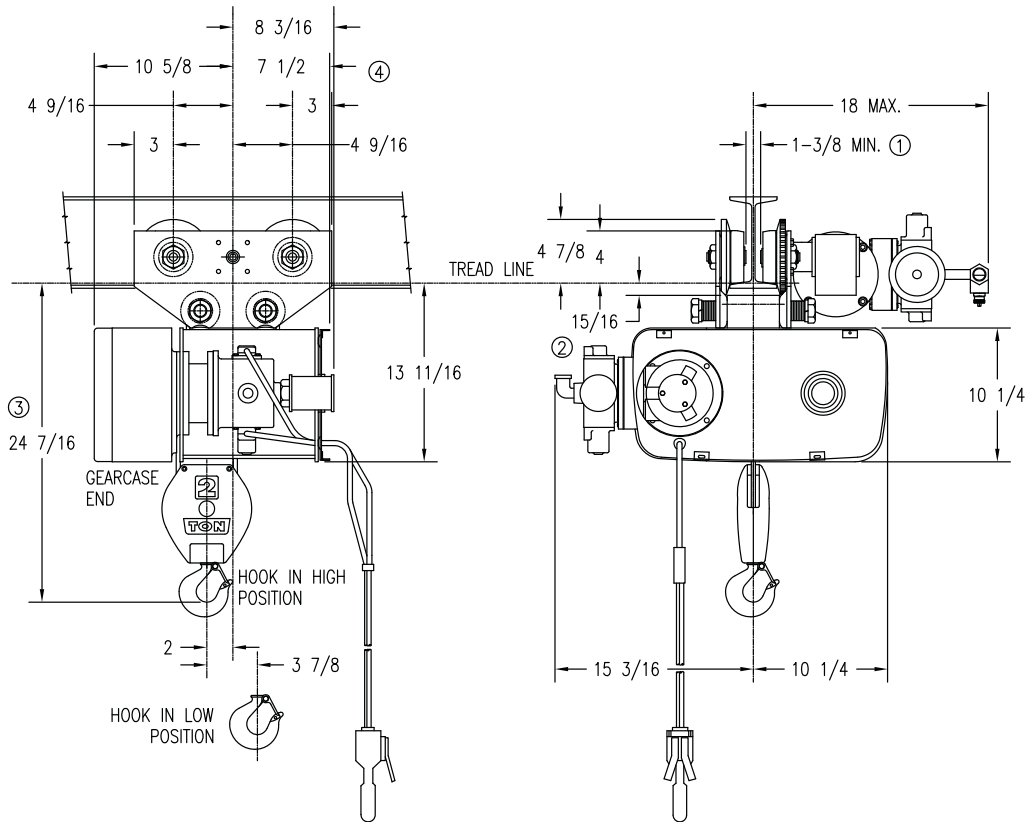

MINIMUM STANDARD RADIUS: 5'-0", FOR SMALLER RADIUS CONTACT FACTORY

CATALOG NUMBER	HOIST				TROLLEY		WEIGHT (LBS)	ESTIMATED WHEEL LOAD*	
	MAX LIFT (FT)	HOIST SPEED (FPM)	MOTOR SIZE	ROPE NO & DIA	SPEED (FPM)	MOTOR SIZE		HIGH HOOK (LBS)	LOW HOOK (LBS)
†80M02-020S16-A	20	16	A	2-5/16	60	A	385	1753	1722

Weights shown are for standard hoists listed. For approximate shipping weights, add 110 lbs. to the net weight given. Consult factory for weights of special hoists. Dimensions shown are in inches unless otherwise noted.

When used on smallest I-beam size, beam must be free of all obstructions, such as clips, suspension bolts, and nuts. Trolleys for wide flange beams refer to Optional Equipment.

Trolley beam size range – beam flange width 3-5/8" min., 6" max; beam depth 7" min. standard, 6-1/4"-8-5/8" with 1st extension, 8-7/8"-11-1/4" with 2nd extension. See Optional Price section for extension pricing.

① Occurs on smallest beam size only. On larger beams, it is increased by the difference in flange width.

② Clearance shown is between lug and wheel tread.

③ Dimension increases 3" when hoist is equipped with screw type limit switch.

④ Dimension increases 4" when hoist is equipped with screw type limit switch.

* Estimated wheel load per one (1) wheel. Includes live and dead load impacts.

† For a Y80 add a "Y" prefix.

**Single
Reeved**

2 Ton

AIR WIRE ROPE

Y80 - 800 Series

MOTOR DRIVEN TROLLEY

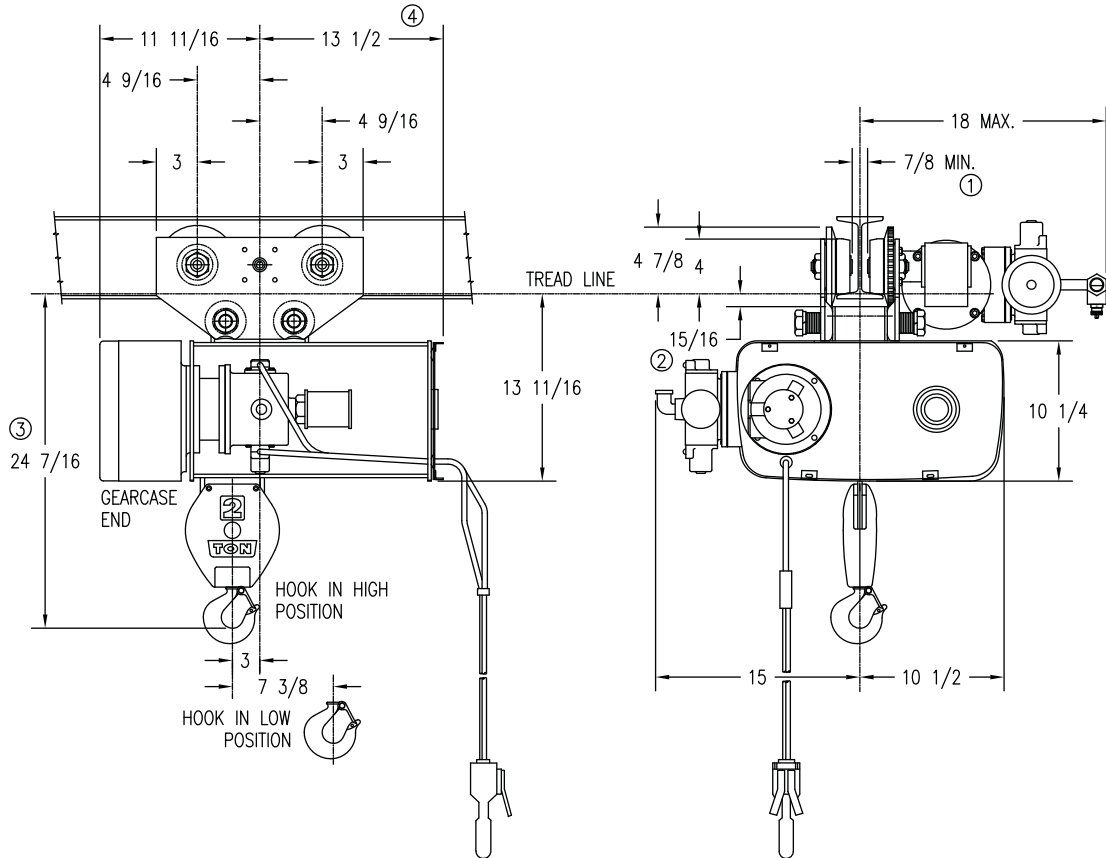

MINIMUM STANDARD RADIUS: 5'-0", FOR SMALLER RADIUS CONTACT FACTORY

CATALOG NUMBER	HOIST				TROLLEY		WEIGHT (LBS)	ESTIMATED WHEEL LOAD*	
	MAX LIFT (FT)	HOIST SPEED (FPM)	MOTOR SIZE	ROPE NO & DIA	SPEED (FPM)	MOTOR SIZE		HIGH HOOK (LBS)	LOW HOOK (LBS)
†80M02-040S16-A	40	16	A	2-5/16	60	A	425	2013	2355

Weights shown are for standard hoists listed. For approximate shipping weights, add 110 lbs. to the net weight given. Consult factory for weights of special hoists. Dimensions shown are in inches unless otherwise noted.

When used on smallest I-beam size, beam must be free of all obstructions, such as clips, suspension bolts, and nuts. Trolleys for wide flange beams refer to Optional Equipment.

Trolley beam size range – beam flange width 3-5/8" min., 6" max; beam depth 7" min. standard, 6-1/4"-8-5/8" with 1st extension, 8-7/8"-11-1/4" with 2nd extension. See Optional Price section for extension pricing.

① Occurs on smallest beam size only. On larger beams, it is increased by the difference in flange width.

② Clearance shown is between lug and wheel tread.

③ Dimension increases 3" when hoist is equipped with screw type limit switch.

④ Dimension increases 4" when hoist is equipped with screw type limit switch.

* Estimated wheel load per one (1) wheel. Includes live and dead load impacts.

† For a Y80 add a "Y" prefix.

Single Reeved

3 Ton

AIR WIRE ROPE

Y80 - 800 Series

MOTOR DRIVEN TROLLEY

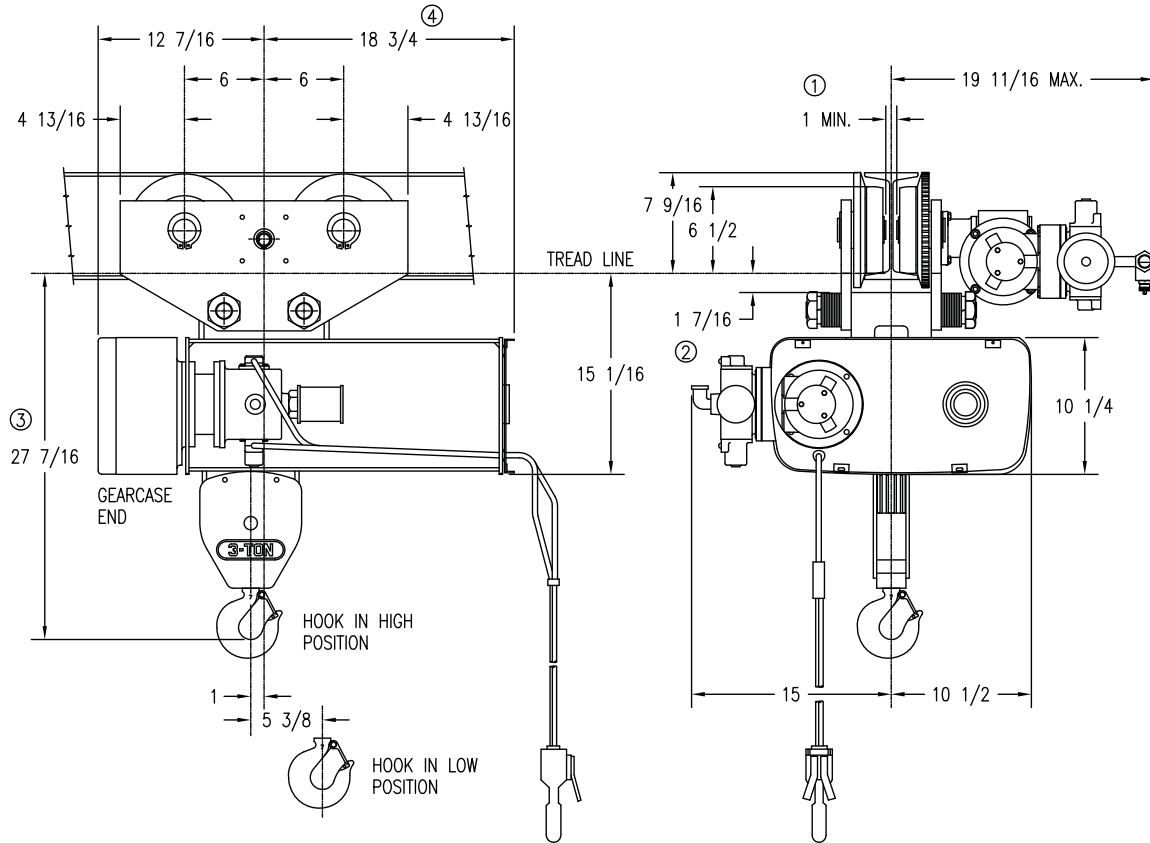

MINIMUM STANDARD RADIUS: 7'-0", FOR SMALLER RADIUS CONTACT FACTORY

CATALOG NUMBER	HOIST				TROLLEY		WEIGHT (LBS)	EST. TROLLEY WHEEL LOAD*	
	MAX LIFT (FT)	HOIST SPEED (FPM)	MOTOR SIZE	ROPE NO & DIA	SPEED (FPM)	MOTOR SIZE		HIGH HOOK (LBS)	LOW HOOK (LBS)
†80M03-030S11-A	30	11	A	4-5/16	50	A	635	2196	3148

Weights shown are for standard hoists listed. For approximate shipping weights, add 110 lbs. to the net weight given. Consult factory for weights of special hoists. Dimensions shown are in inches unless otherwise noted.

When used on smallest I-beam size, beam must be free of all obstructions, such as clips, suspension bolts, and nuts. Trolleys for wide flange beams refer to Optional Equipment.

Trolley beam size range – beam flange width 4" min., 6-1/4" max; beam depth 8" min. standard, 6-3/8"-8-5/8" with 1st extension, 8-3/4"-11" with 2nd extension. See Optional Price section for extension pricing.

① Occurs on smallest beam size only. On larger beams, it is increased by the difference in flange width.

② Clearance shown is between lug and wheel tread.

③ Dimension increases 3" when hoist is equipped with screw type limit switch.

④ Dimension increases 4" when hoist is equipped with screw type limit switch.

* Estimated wheel load per one (1) wheel. Includes live and dead load impacts.

† For a Y80 add a "Y" prefix.

**Single
Reeved**

3 Ton

AIR WIRE ROPE

Y80 - 800 Series

MOTOR DRIVEN TROLLEY

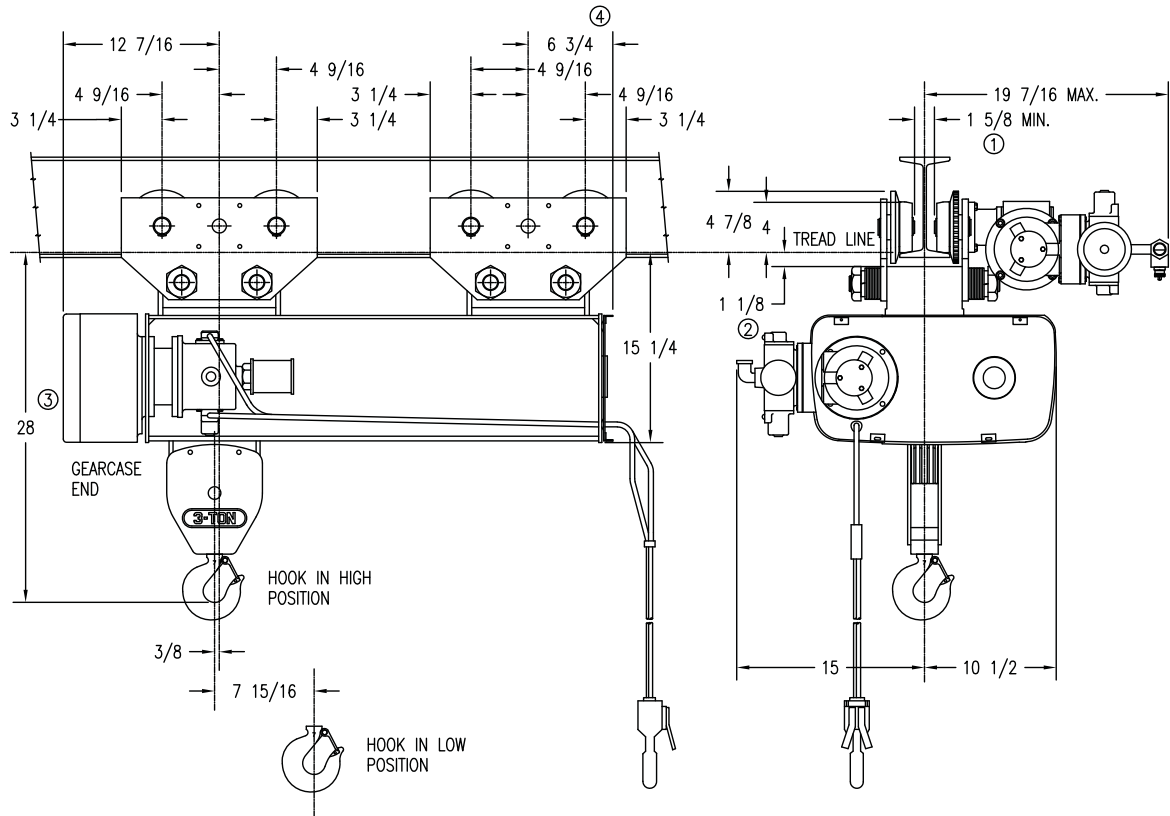

MINIMUM RADIUS: Straight Track ⑤

CATALOG NUMBER	HOIST				TROLLEY		WEIGHT (LBS)	EST. TROLLEY WHEEL LOAD*	
	MAX LIFT (FT)	HOIST SPEED (FPM)	MOTOR SIZE	ROPE NO & DIA	SPEED (FPM)	MOTOR SIZE		HIGH HOOK (LBS)	LOW HOOK (LBS)
†80M03-045S11-A	45	11	A	4-5/16	50	A	755	1839	1316

Weights shown are for standard hoists listed. For approximate shipping weights, add 110 lbs. to the net weight given. Consult factory for weights of special hoists. Dimensions shown are in inches unless otherwise noted.

When used on smallest I-beam size, beam must be free of all obstructions, such as clips, suspension bolts, and nuts. Trolleys for wide flange beams refer to Optional Equipment.

Trolley beam size range – beam flange width 4" min., 6-1/4" max; beam depth 8" min. standard, 6-3/8"-8-5/8" with 1st extension, 8-3/4"-11" with 2nd extension. See Optional Price section for extension pricing.

① Occurs on smallest beam size only. On larger beams, it is increased by the difference in flange width.

② Clearance shown is between lug and wheel tread.

③ Dimension increases 3" when hoist is equipped with screw type limit switch.

④ Dimension increases 4" when hoist is equipped with screw type limit switch.

⑤ Can negotiate curves with addition of swivel trolley from the option pricing section. Headroom increases by 4-5/8".

* Estimated wheel load per one (1) wheel. Includes live and dead load impacts.

† For a Y80 add a "Y" prefix.

Single
Reeved

5 Ton

AIR WIRE ROPE

Y80 - 800 Series

MOTOR DRIVEN TROLLEY

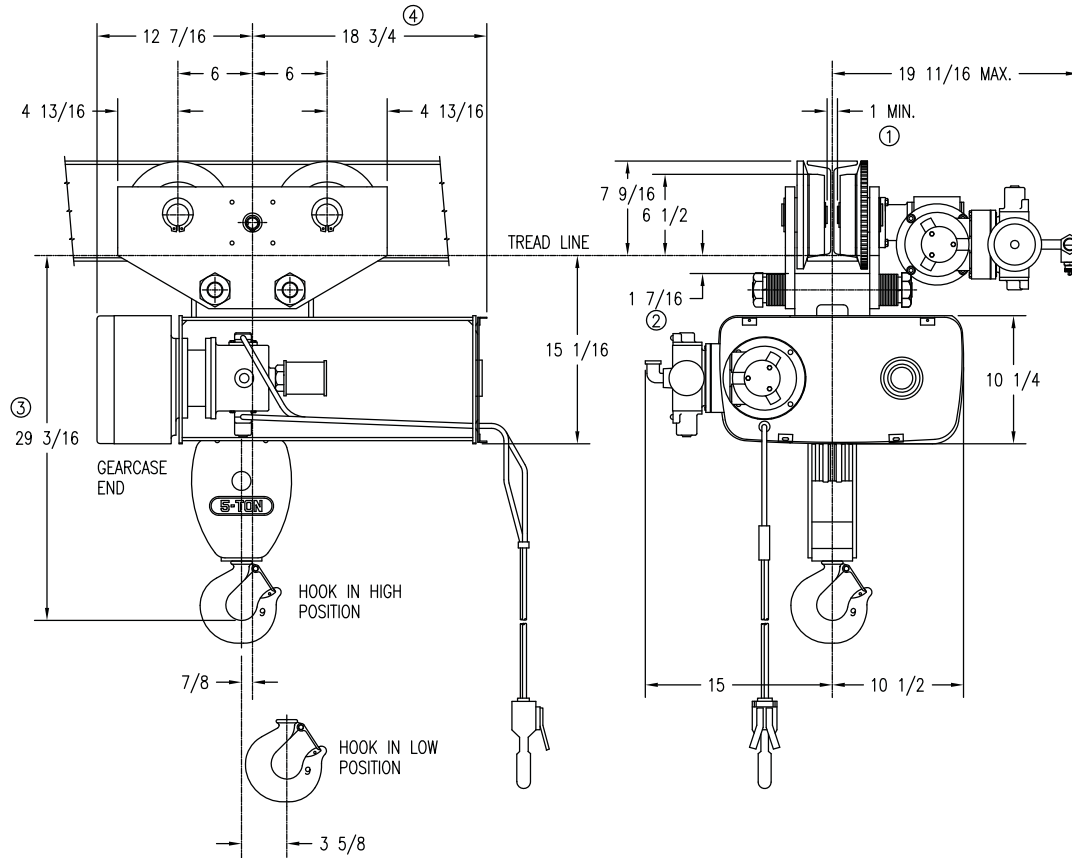

MINIMUM STANDARD RADIUS: 7'-0", FOR SMALLER RADIUS CONTACT FACTORY

CATALOG NUMBER	HOIST				TROLLEY		WEIGHT (LBS)	ESTIMATED WHEEL LOAD*	
	MAX LIFT (FT)	HOIST SPEED (FPM)	MOTOR SIZE	ROPE NO & DIA	SPEED (FPM)	MOTOR SIZE		HIGH HOOK (LBS)	LOW HOOK (LBS)
†80M05-020S07-A	20	07	A	6-5/16	50	A	655	3474	4373

Weights shown are for standard hoists listed. For approximate shipping weights, add 110 lbs. to the net weight given. Consult factory for weights of special hoists. Dimensions shown are in inches unless otherwise noted.

When used on smallest I-beam size, beam must be free of all obstructions, such as clips, suspension bolts, and nuts. Trolleys for wide flange beams refer to Optional Equipment.

Trolley beam size range – beam flange width 4" min., 6-1/4" max; beam depth 8" min. standard, 6-3/8"-8-5/8" with 1st extension, 8-3/4"-11" with 2nd extension. See Optional Price section for extension pricing.

① Occurs on smallest beam size only. On larger beams, it is increased by the difference in flange width.

② Clearance shown is between lug and wheel tread.

③ Dimension increases 3" when hoist is equipped with screw type limit switch.

④ Dimension increases 4" when hoist is equipped with screw type limit switch.

* Estimated wheel load per one (1) wheel. Includes live and dead load impacts.

† For a Y80 add a "Y" prefix.

**Single
Reeved**

5 Ton

AIR WIRE ROPE

Y80 - 800 Series

MOTOR DRIVEN TROLLEY

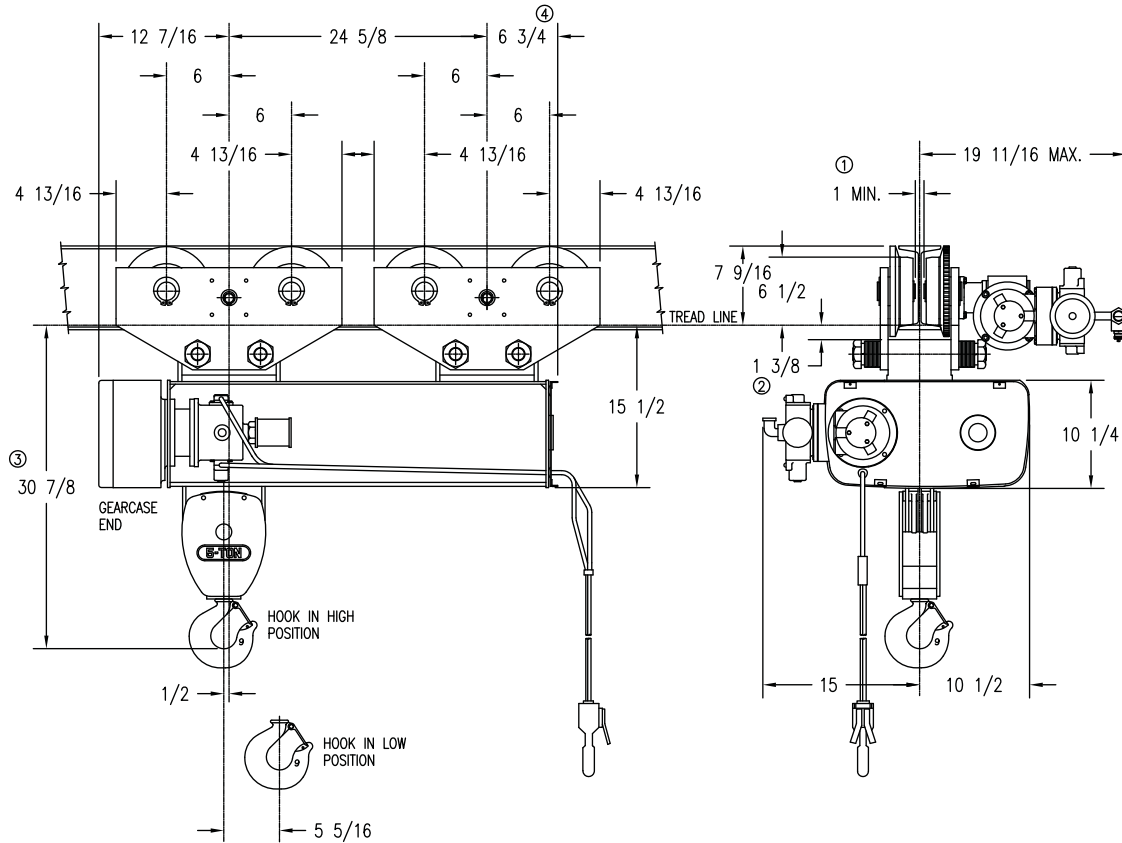

MINIMUM RADIUS: Straight Track ⑤

CATALOG NUMBER	HOIST				TROLLEY		WEIGHT (LBS)	ESTIMATED WHEEL LOAD*	
	MAX LIFT (FT)	HOIST SPEED (FPM)	MOTOR SIZE	ROPE NO & DIA	SPEED (FPM)	MOTOR SIZE		HIGH HOOK (LBS)	LOW HOOK (LBS)
†80M05-030S07-A	30	07	A	6-5/16	50	A	850	2992	2359

Weights shown are for standard hoists listed. For approximate shipping weights, add 110 lbs. to the net weight given. Consult factory for weights of special hoists. Dimensions shown are in inches unless otherwise noted.

When used on smallest I-beam size, beam must be free of all obstructions, such as clips, suspension bolts, and nuts. Trolleys for wide flange beams refer to Optional Equipment.

Trolley beam size range – beam flange width 4" min., 6-1/4" max; beam depth 8" min. standard, 6-3/8"-8-5/8" with 1st extension, 8-3/4"-11" with 2nd extension. See Optional Price section for extension pricing.

- ① Occurs on smallest beam size only. On larger beams, it is increased by the difference in flange width.
- ② Clearance shown is between lug and wheel tread.
- ③ Dimension increases 3" when hoist is equipped with screw type limit switch.
- ④ Dimension increases 4" when hoist is equipped with screw type limit switch.
- ⑤ Can negotiate curves with addition of swivel trolley from the option pricing section. Headroom increases by 4-5/8".

* Estimated wheel load per one (1) wheel. Includes live and dead load impacts.

† For a Y80 add a "Y" prefix.

Standard Features

Dimensions & Specifications

AIR WIRE ROPE

Y80 - 800 Series

Double Reeved Air Hoists with Motor Driven Trolleys

Feature	1 Ton	2 Ton
Service Class	H-4	H-4
Reeved	4 PD - 3/16"	4 PD - 1/4'
Hoist Gearing	Triple reduction Helical/Spur	Triple reduction Helical/Spur
Hook Assembly	Bearing Thrust Washer 360 degree rotate	Bearing Thrust Washer 360 degree rotate
Hoist Motor	Vane-type Air Motor	Vane-type Air Motor
Hoist Motor Brake	Optional Air-Operated	Optional Air-Operated
Hoist Control	Variable Speed	Variable Speed
Hoist Limit Switch	Upper block control circuit	Upper block control circuit
Rope Drum Diameter	7-1/2"	7-1/2"
Rope Drum Material	Cast Iron	Cast Iron
Sheave Diameter	5"	5"
Sheave Material	Steel	Steel
Trolley Gearing	Worm	Worm
Trolley Motor	Vane-type Air Motor	Vane-type Air Motor
Trolley Control	Variable Speed	Variable Speed
Wheels	4"	4"
Bumpers	Optional Rubber	Optional Rubber
Bearings	Anti-friction	Anti-friction

**Double
Reeved**

1 Ton

AIR WIRE ROPE

Y80 - 800 Series

MOTOR DRIVEN TROLLEY

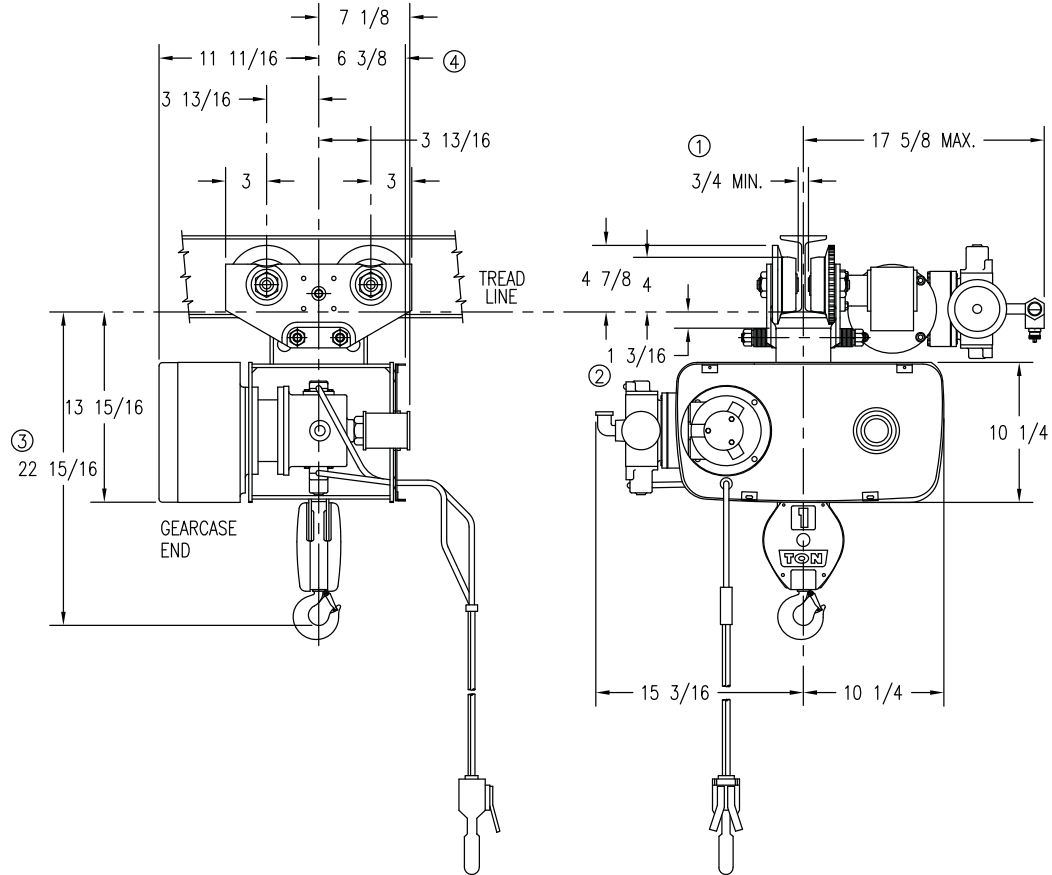

MINIMUM STANDARD RADIUS: 4'-0", FOR SMALLER RADIUS CONTACT FACTORY

CATALOG NUMBER	HOIST				TROLLEY		WEIGHT (LBS)	ESTIMATED WHEEL LOAD* (LBS)
	MAX LIFT (FT)	HOIST SPEED (FPM)	MOTOR SIZE	ROPE NO & DIA	SPEED (FPM)	MOTOR SIZE		
†80M01-018D33-A	18	33	A	4-3/16	75	A	310	668

Weights shown are for standard hoists listed. For approximate shipping weights, add 110 lbs. to the net weight given. Consult factory for weights of special hoists. Dimensions shown are in inches unless otherwise noted.

When used on smallest I-beam size, beam must be free of all obstructions, such as clips, suspension bolts, and nuts. Trolleys for wide flange beams refer to Optional Equipment.

Trolley beam size range – beam flange width 3" min., 5" max; beam depth 6" min. standard, 5-1/8"-7-1/4" with 1st extension, 7-1/2"-9-1/8" with 2nd extension. See Optional Price section for extension pricing.

① Occurs on smallest beam size only. On larger beams, it is increased by the difference in flange width.

② Clearance shown is between lug and wheel tread.

③ Dimension increases 3" when hoist is equipped with screw type limit switch.

④ Dimension increases 4" when hoist is equipped with screw type limit switch.

* Estimated wheel load per one (1) wheel. Includes live and dead load impacts.

† For a Y80 add a "Y" prefix.

Double Reeved

1 Ton

AIR WIRE ROPE

Y80 - 800 Series

MOTOR DRIVEN TROLLEY

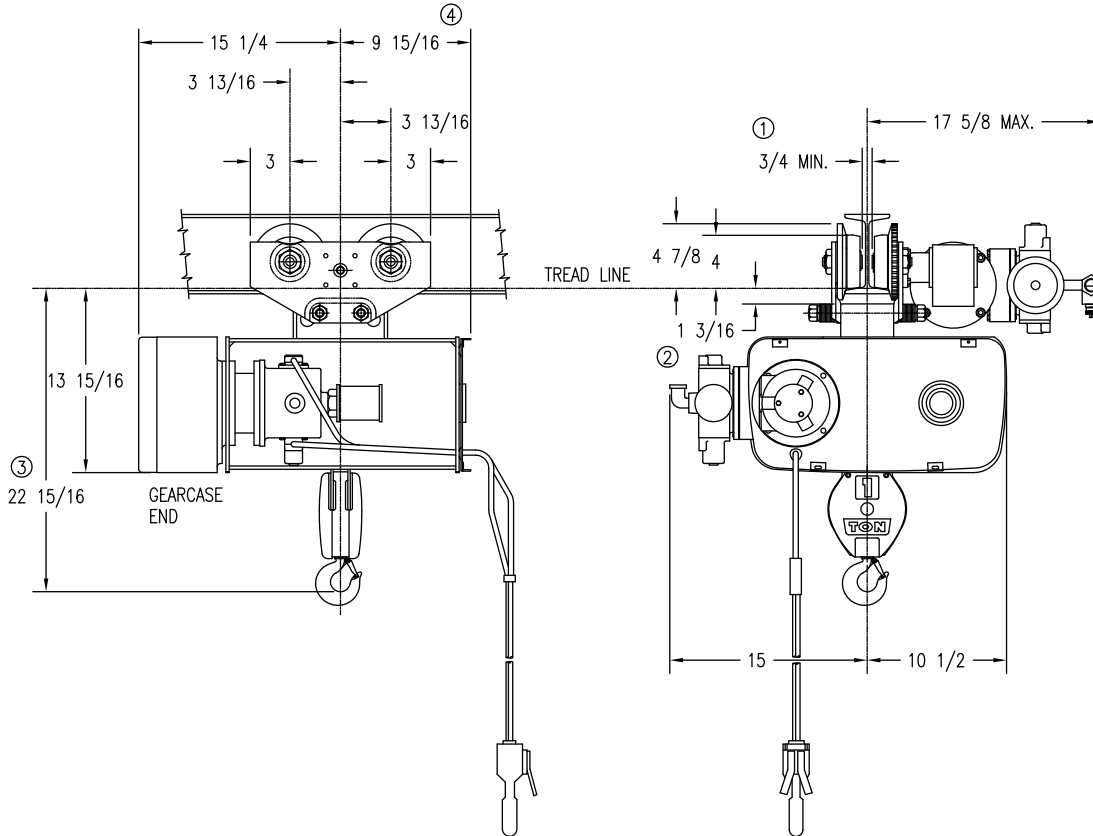

MINIMUM STANDARD RADIUS: 4'-0", FOR SMALLER RADIUS CONTACT FACTORY

CATALOG NUMBER	HOIST				TROLLEY		WEIGHT (LBS)	ESTIMATED WHEEL LOAD* (LBS)
	MAX LIFT (FT)	HOIST SPEED (FPM)	MOTOR SIZE	ROPE NO & DIA	SPEED (FPM)	MOTOR SIZE		
†80M01-034D33-A	34	33	A	4-3/16	75	A	430	701

Weights shown are for standard hoists listed. For approximate shipping weights, add 110 lbs. to the net weight given. Consult factory for weights of special hoists. Dimensions shown are in inches unless otherwise noted.

When used on smallest I-beam size, beam must be free of all obstructions, such as clips, suspension bolts, and nuts. Trolleys for wide flange beams refer to Optional Equipment.

Trolley beam size range – beam flange width 3" min., 5" max; beam depth 6" min. standard, 5-1/8"-7-1/4" with 1st extension, 7-1/2"-9-1/8" with 2nd extension. See Optional Price section for extension pricing.

① Occurs on smallest beam size only. On larger beams, it is increased by the difference in flange width.

② Clearance shown is between lug and wheel tread.

③ Dimension increases 3" when hoist is equipped with screw type limit switch.

④ Dimension increases 4" when hoist is equipped with screw type limit switch.

* Estimated wheel load per one (1) wheel. Includes live and dead load impacts.

† For a Y80 add a "Y" prefix.

**Double
Reeved**

2 Ton

AIR WIRE ROPE

Y80 - 800 Series

MOTOR DRIVEN TROLLEY

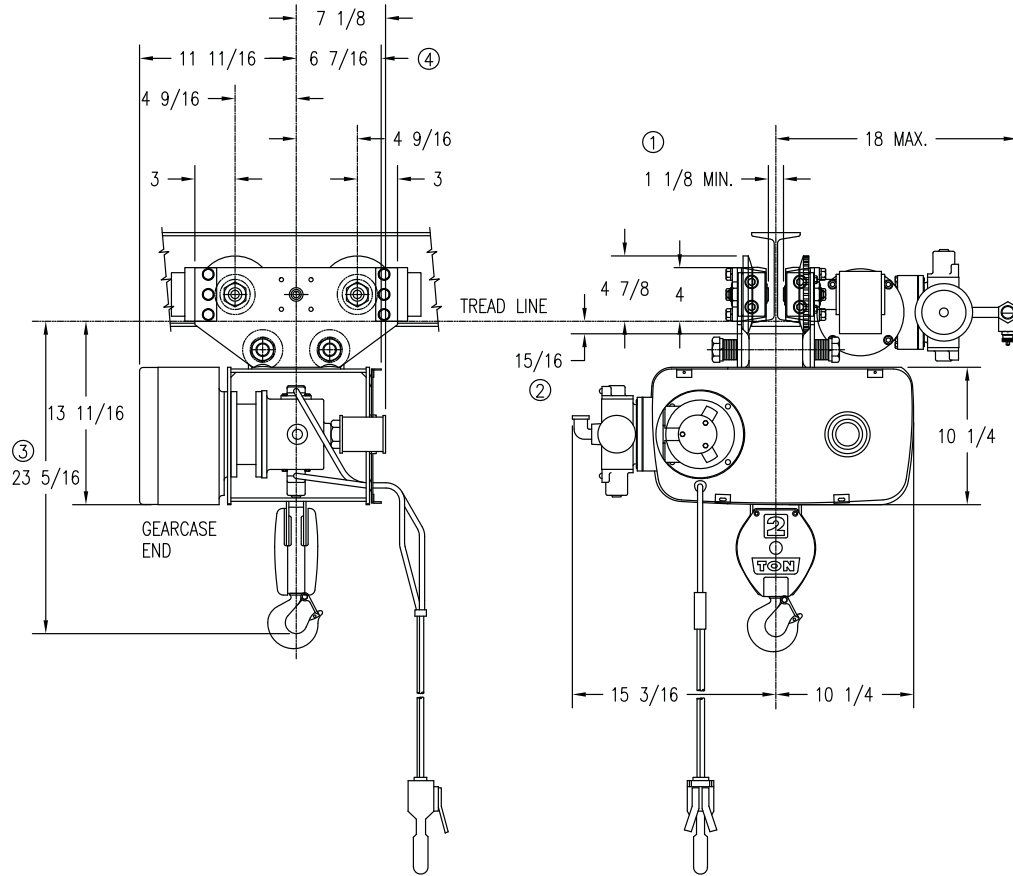

MINIMUM STANDARD RADIUS: 5'-0", FOR SMALLER RADIUS CONTACT FACTORY

CATALOG NUMBER	HOIST				TROLLEY		WEIGHT (LBS)	ESTIMATED WHEEL LOAD* (LBS)
	MAX LIFT (FT)	HOIST SPEED (FPM)	MOTOR SIZE	ROPE NO & DIA	SPEED (FPM)	MOTOR SIZE		
†80M02-014D16-A	14	16	A	4-1/4	75	A	400	1260

Weights shown are for standard hoists listed. For approximate shipping weights, add 110 lbs. to the net weight given. Consult factory for weights of special hoists. Dimensions shown are in inches unless otherwise noted.

When used on smallest I-beam size, beam must be free of all obstructions, such as clips, suspension bolts, and nuts. Trolleys for wide flange beams refer to Optional Equipment.

Trolley beam size range – beam flange width 3-3/8" min., 6" max; beam depth 7" min. standard, 6-1/4"-8-5/8" with 1st extension, 8-7/8"-11-1/4" with 2nd extension. See Optional Price section for extension pricing.

① Occurs on smallest beam size only. On larger beams, it is increased by the difference in flange width.

② Clearance shown is between lug and wheel tread.

③ Dimension increases 3" when hoist is equipped with screw type limit switch.

④ Dimension increases 4" when hoist is equipped with screw type limit switch.

* Estimated wheel load per one (1) wheel. Includes live and dead load impacts.

† For a Y80 add a "Y" prefix.

Double Reeved

2 Ton

AIR WIRE ROPE

Y80 - 800 Series

MOTOR DRIVEN TROLLEY

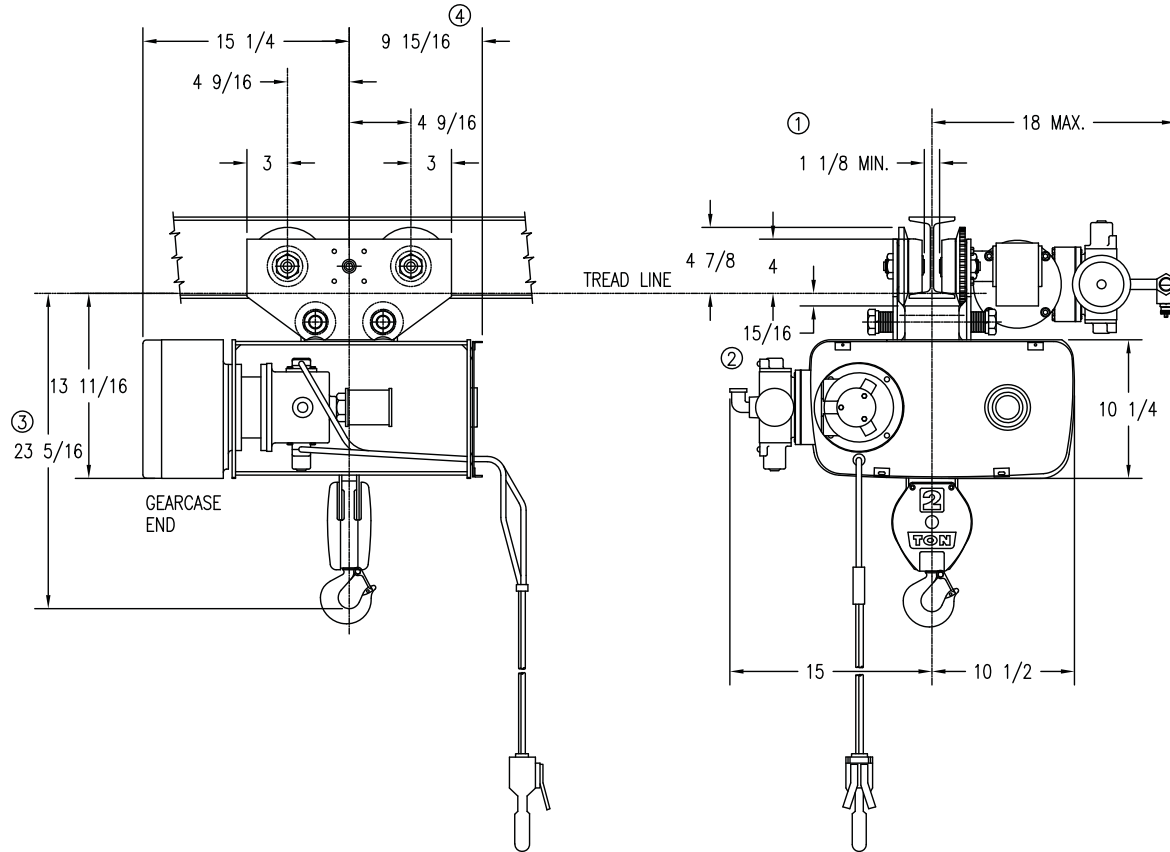

MINIMUM STANDARD RADIUS: 5'-0", FOR SMALLER RADIUS CONTACT FACTORY

CATALOG NUMBER	HOIST				TROLLEY		WEIGHT (LBS)	ESTIMATED WHEEL LOAD* (LBS)
	MAX LIFT (FT)	HOIST SPEED (FPM)	MOTOR SIZE	ROPE NO & DIA	SPEED (FPM)	MOTOR SIZE		
†80M02-025D16-A	25	16	A	4-1/4	75	A	435	1270

Weights shown are for standard hoists listed. For approximate shipping weights, add 110 lbs. to the net weight given. Consult factory for weights of special hoists. Dimensions shown are in inches unless otherwise noted.

When used on smallest I-beam size, beam must be free of all obstructions, such as clips, suspension bolts, and nuts. Trolleys for wide flange beams refer to Optional Equipment.

Trolley beam size range – beam flange width 3-3/8" min., 6" max; beam depth 7" min. standard, 6-1/4"-8-5/8" with 1st extension, 8-7/8"-11-1/4" with 2nd extension. See Optional Price section for extension pricing.

- ① Occurs on smallest beam size only. On larger beams, it is increased by the difference in flange width.
- ② Clearance shown is between lug and wheel tread.
- ③ Dimension increases 3" when hoist is equipped with screw type limit switch.
- ④ Dimension increases 4" when hoist is equipped with screw type limit switch.

* Estimated wheel load per one (1) wheel. Includes live and dead load impacts.

† For a Y80 add a "Y" prefix.

Standard Features

Dimensions & Specifications

ELECTRIC WIRE ROPE

**700 Series
Size 2**

Single Reeved Electric Hoists with Motor Driven Trolleys

Feature	3 Ton	5 Ton	7½ Ton	10 Ton
Service Class	H-4	H-4	H-4	H-4
Reeved	4 PS - 3/8" for 26' lift 2 PS - 7/16" for 44' lift	4 PS - 3/8"	4 PS - 7/16"	6 PS - 7/16"
Hoist Gearing	Double Reduction Helical Gearing	Double Reduction Helical Gearing	Double Reduction Helical Gearing	Double Reduction Helical Gearing
Hook Assembly	Bearing-mounted 360 degree rotate	Bearing-mounted 360 degree rotate	Bearing-mounted 360 degree rotate	Bearing-mounted 360 degree rotate
Hoist Motor	30-minute rated TENV	30-minute rated TENV	30-minute rated TENV	30-minute rated TENV
Hoist Motor Brake	100% Torque DC disc	100% Torque DC disc	100% Torque DC disc	100% Torque DC disc
Load Brake	Weston type	Weston type	Weston type	Weston type
Hoist Control	1-speed	1-speed	1-speed	1-speed
Control Circuit voltage	115 Volts	115 Volts	115 Volts	115 Volts
Hoist Limit Switch	Upper block control circuit	Upper block control circuit	Upper block control circuit	Upper block control circuit
Rope Drum Diameter	9"	9"	9"	9"
Rope Drum Material	Cast Iron	Cast Iron	Cast Iron	Steel
Sheave Diameter	9"	9"	9"	9"
Sheave Material	Cast Iron	Cast Iron	Cast Iron	Cast Iron
Trolley Gearing	Worm	Worm	Worm	Worm
Trolley Motor	30-minute rated TENV	30-minute rated TENV	30-minute rated TENV	30-minute rated TENV
Trolley Brake	Optional AC Disc	Optional AC Disc	Optional AC Disc	Optional AC Disc
Trolley Control	1-speed	1-speed	1-speed	1-speed
Wheels	6-1/2"	6-1/2"	6-1/2"	6-1/2"
Bumpers	Optional Rubber	Optional Rubber	Optional Rubber	Optional Rubber
Bearings	Anti-friction	Anti-friction	Anti-friction	Anti-friction
Motor TAS	Standard	Standard	Standard	Standard
Control Enclosure	NEMA 1	NEMA 1	NEMA 1	NEMA 1

**Single
Reeved**

3 Ton

ELECTRIC WIRE ROPE

**700 Series
Size 2**

MOTOR DRIVEN TROLLEY

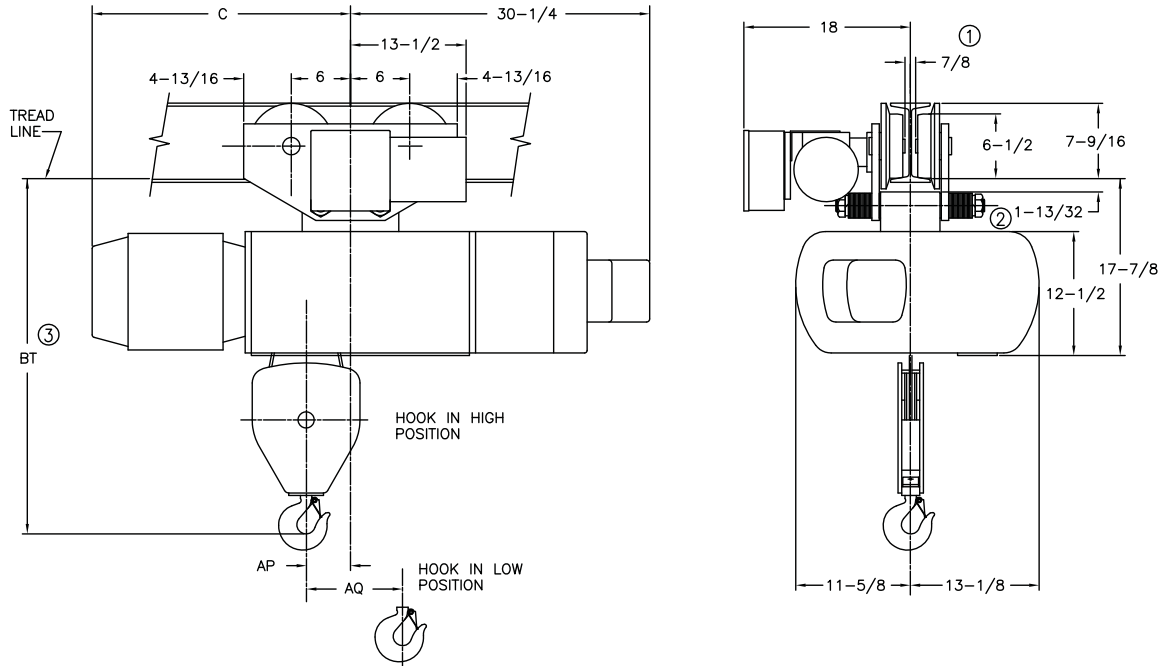

MINIMUM STANDARD RADIUS: 7'-0", FOR SMALLER RADIUS CONTACT FACTORY

CATALOG NUMBER	HOIST				TROLLEY		WEIGHT (LBS)	BT	C	AP	AQ	ESTIMATED WHEEL LOAD*	
	MAX LIFT (FT)	HOIST SPEED (FPM)	HP	ROPE NO & DIA	SPEED (FPM)	HP						HIGH HOOK (LBS)	LOW HOOK (LBS)
72M03-026S15-1	26	15	3	4-3/8	50	1/2	1035	38	22-3/8	3-3/4	4-7/8	3088	2333
72M03-026S15-2	26	15/5	3/1	4-3/8	50	1/2	1060	38	24-1/2	3-3/4	4-7/8	3095	2340
72M03-026S20-1	26	20	5	4-3/8	50	1/2	1050	38	22-3/4	3-3/4	4-7/8	3092	2337
72M03-026S20-2	26	20/7	5/1.6	4-3/8	50	1/2	1110	38	28	3-3/4	4-7/8	3108	2354
72M03-044S30-1	44	30	7.5	2-7/16	50	1/2	1030	38-7/8	25-5/8	4-1/2	9-3/4	3302	3518
72M03-044S30-2	44	30/10	7.5/2.5	2-7/16	50	1/2	1080	38-7/8	28-7/8	4-1/2	9-3/4	3316	3531
72M03-044S40-1	44	40	7.5	2-7/16	50	1/2	1030	38-7/8	25-5/8	4-1/2	9-3/4	3433	3658
72M03-044S40-2	44	40/13	7.5/2.5	2-7/16	50	1/2	1080	38-7/8	28-7/8	4-1/2	9-3/4	3447	3672

Weights shown are for standard hoists listed. For approximate shipping weights, add 110 lbs. to the net weight given. Consult factory for weights of special hoists. Dimensions shown are in inches unless otherwise noted.

When used on smallest I-beam size, beam must be free of all obstructions, such as clips, suspension bolts, and nuts. Trolleys for wide flange beams refer to Optional Equipment.

Trolley beam size range – beam flange width 4" min., 6-1/4" max; beam depth 8" min. standard, 6-3/8"-8-5/8" with 1st extension, 8-3/4"-11" with 2nd extension. See Optional Price section for extension pricing.

① Occurs on smallest beam size only. On larger beams, it is increased by the difference in flange width.

② Clearance shown is between lug and wheel tread.

③ Dimension increases 3" when hoist is equipped with screw type limit switch.

NOTE: Hoists with speeds 30 F.P.M. and over are equipped with screw and block type limit switches.

* Estimated wheel load per one (1) wheel. Includes live and dead load impacts.

Single Reeved

5 Ton

ELECTRIC WIRE ROPE

700 Series
Size 2

MOTOR DRIVEN TROLLEY

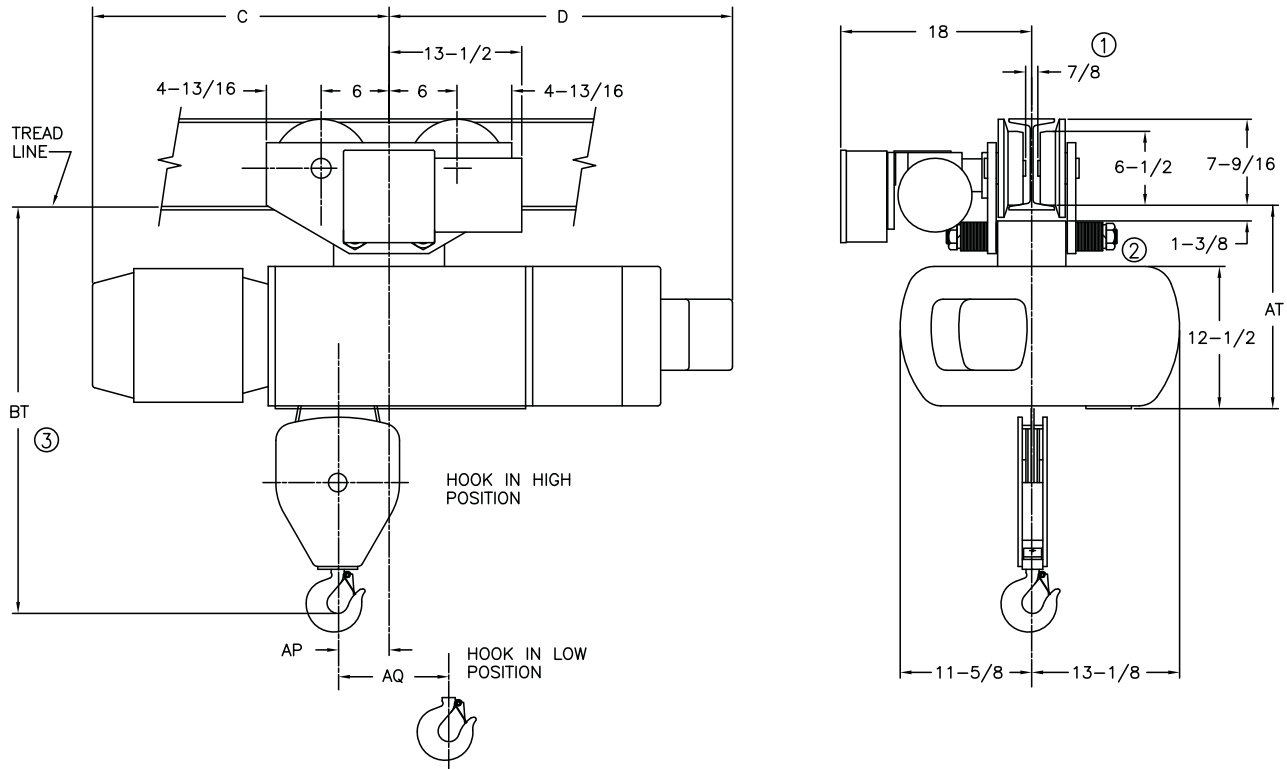

MINIMUM STANDARD RADIUS: 7'-0", FOR SMALLER RADIUS CONTACT FACTORY

CATALOG NUMBER	HOIST				TROLLEY		WEIGHT (LBS)	AT	BT	C	D	F	AP	AQ	ESTIMATED WHEEL LOAD*	
	MAX LIFT (FT)	HOIST SPEED (FPM)	HP	ROPE NO & DIA	SPEED (FPM)	HP									HIGH HOOK (LBS)	LOW HOOK (LBS)
72M05-026S15-1	26	15	5	4-3/8	50	1/2	1050	17-7/8	37-7/8	22-3/4	30-1/2	1-13/32	3-3/4	4-7/8	4961	3703
72M05-026S15-2	26	15/5	5/1.6	4-3/8	50	1/2	1110	17-7/8	37-7/8	28	30-1/2	1-13/32	3-3/4	4-7/8	4977	3719

Weights shown are for standard hoists listed. For approximate shipping weights, add 110 lbs. to the net weight given. Consult factory for weights of special hoists. Dimensions shown are in inches unless otherwise noted.

When used on smallest I-beam size, beam must be free of all obstructions, such as clips, suspension bolts, and nuts. Trolleys for wide flange beams refer to Optional Equipment.

Trolley beam size range – beam flange width 4" min., 6-1/4" max; beam depth 8" min. standard, 6-3/8"-8-5/8" with 1st extension, 8-3/4"-11" with 2nd extension. See Optional Price section for extension pricing.

① Occurs on smallest beam size only. On larger beams, it is increased by the difference in flange width.

② Clearance shown is between lug and wheel tread.

③ Dimension increases 3" when hoist is equipped with screw type limit switch.

* Estimated wheel load per one (1) wheel. Includes live and dead load impacts.

**Single
Reeved**

5 Ton

ELECTRIC WIRE ROPE

**700 Series
Size 2**

MOTOR DRIVEN TROLLEY

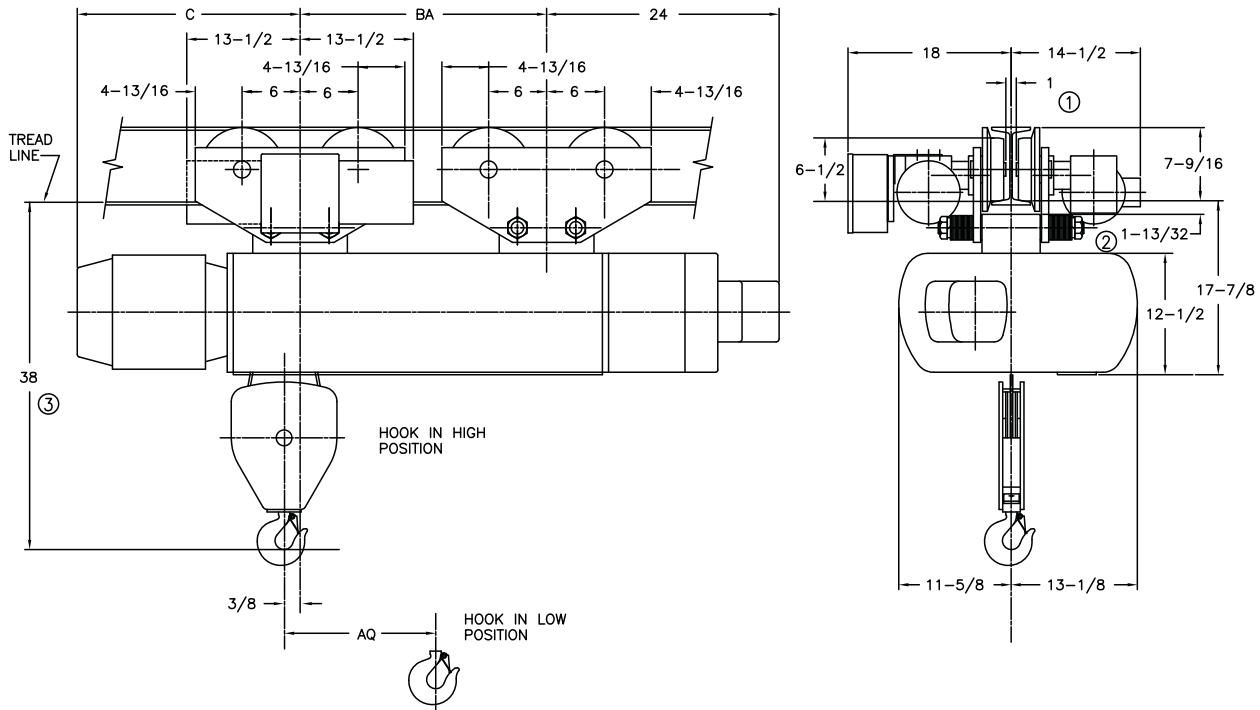

MINIMUM RADIUS: Straight Track ④

CATALOG NUMBER	HOIST			TROLLEY		WEIGHT (LBS)	C	BA	AQ	ESTIMATED WHEEL LOAD*		
	MAX LIFT (FT)	HOIST SPEED (FPM)	HP	ROPE NO & DIA	SPEED (FPM)					HP	HIGH HOOK (LBS)	LOW HOOK (LBS)
72M05-047S15-1	47	15	5	4-3/8	50	(2) 1/4	1635	22-5/8	25-3/8	8-3/4	3118	2169
72M05-047S15-2	47	15/5	5/1.66	4-3/8	50	(2) 1/4	1660	25-3/4	25-3/8	8-3/4	3122	2172
72M05-047S20-1	47	20	7.5	4-3/8	50	(2) 1/4	1685	22-5/8	25-3/8	8-3/4	3125	2177
72M05-047S20-2	47	20/7	7.5/2.5	4-3/8	50	(2) 1/4	1705	25-3/4	25-3/8	8-3/4	3128	2180

Weights shown are for standard hoists listed. For approximate shipping weights, add 110 lbs. to the net weight given. Consult factory for weights of special hoists. Dimensions shown are in inches unless otherwise noted.

When used on smallest I-beam size, beam must be free of all obstructions, such as clips, suspension bolts, and nuts. Trolleys for wide flange beams refer to Optional Equipment.

Trolley beam size range – beam flange width 4" min., 6-1/4" max; beam depth 8" min. standard, 6-3/8"-8-5/8" with 1st extension, 8-3/4"-11" with 2nd extension. See Optional Price section for extension pricing.

① Occurs on smallest beam size only. On larger beams, it is increased by the difference in flange width.

② Clearance shown is between lug and wheel tread.

③ Dimension increases 3" when hoist is equipped with screw type limit switch.

NOTE: Increases on the 75 foot lift hoists only which are equipped with screw and block type limit switch.

④ Can negotiate curves with addition of swivel trolley from the option pricing section. Headroom increases by 4-5/8".

* Estimated wheel load per one (1) wheel. Includes live and dead load impacts.

**Single
Reeved**

7½ Ton

ELECTRIC WIRE ROPE

**700 Series
Size 2**

MOTOR DRIVEN TROLLEY

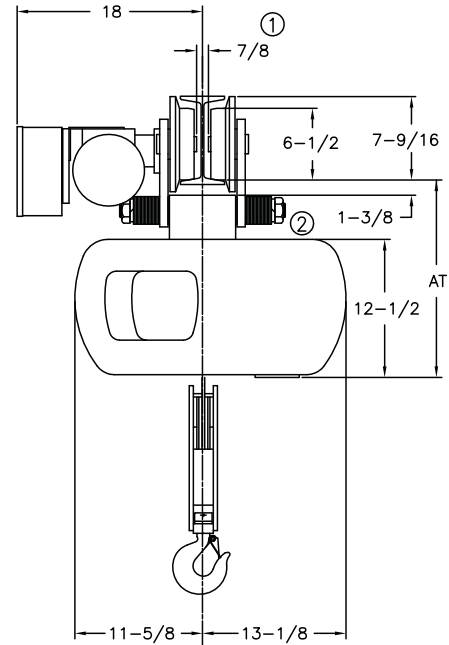
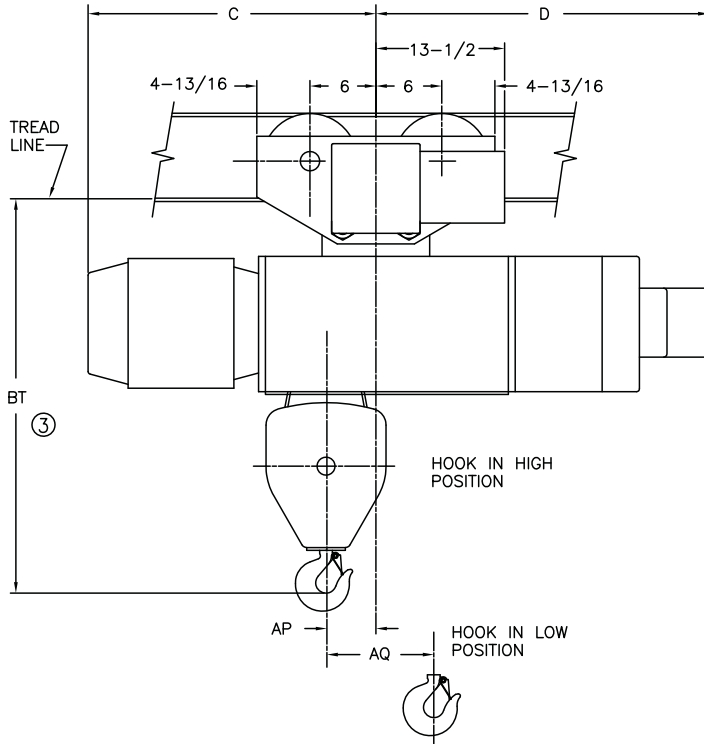

MINIMUM STANDARD RADIUS: 7'-0", FOR SMALLER RADIUS CONTACT FACTORY

CATALOG NUMBER	HOIST				TROLLEY		WEIGHT (LBS)	AT	BT	C	D	F	AP	AQ	ESTIMATED WHEEL LOAD*	
	MAX LIFT (FT)	HOIST SPEED (FPM)	HP	ROPE NO & DIA	SPEED (FPM)	HP									HIGH HOOK (LBS)	LOW HOOK (LBS)
72M07-022S14-1	22	14	7.5	4-7/16	50	1/2	1100	17-7/8	38	25-5/8	30-1/2	1-3/8	3-1/4	4-3/4	6951	5693
72M07-022S14-2	22	14/5	7.5/2.5	4-7/16	50	1/2	1150	17-7/8	38	28-7/8	30-1/2	1-3/8	3-1/4	4-3/4	6965	5707

Weights shown are for standard hoists listed. For approximate shipping weights, add 110 lbs. to the net weight given. Consult factory for weights of special hoists. Dimensions shown are in inches unless otherwise noted.

When used on smallest I-beam size, beam must be free of all obstructions, such as clips, suspension bolts, and nuts. Trolleys for wide flange beams refer to Optional Equipment.

Trolley beam size range – beam flange width 4" min., 6-1/4" max; beam depth 8" min. standard, 6-3/8"-8-5/8" with 1st extension, 8-3/4"-11" with 2nd extension. See Optional Price section for extension pricing.

① Occurs on smallest beam size only. On larger beams, it is increased by the difference in flange width.

② Clearance shown is between lug and wheel tread.

③ Dimension increases 3" when hoist is equipped with screw type limit switch.

* Estimated wheel load per one (1) wheel. Includes live and dead load impacts.

**Single
Reeved**

7½ Ton

ELECTRIC WIRE ROPE

**700 Series
Size 2**

MOTOR DRIVEN TROLLEY

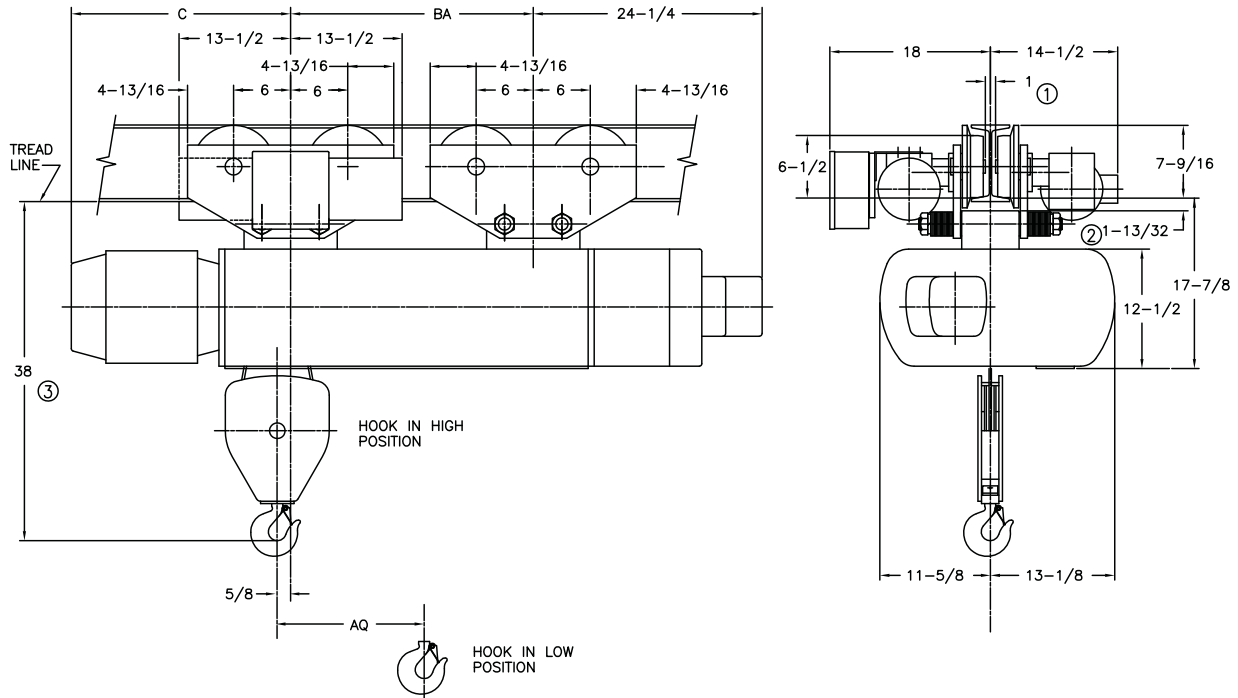

MINIMUM RADIUS: Straight Track ④

CATALOG NUMBER	HOIST			TROLLEY		WEIGHT (LBS)	C	BA	AQ	ESTIMATED WHEEL LOAD*		
	MAX LIFT (FT)	HOIST SPEED (FPM)	HP	ROPE NO & DIA	SPEED (FPM)					HP	HIGH HOOK (LBS)	LOW HOOK (LBS)
72M07-038S14-1	38	14	7.5	4-7/16	50	(2) 1/4	1690	21-1/4	25-3/8	8-1/2	4528	3144
72M07-038S14-2	38	14/5	7.5/2.5	4-7/16	50	(2) 1/4	1715	25-3/4	25-3/8	8-1/2	4531	3148

Weights shown are for standard hoists listed. For approximate shipping weights, add 110 lbs. to the net weight given. Consult factory for weights of special hoists. Dimensions shown are in inches unless otherwise noted.

When used on smallest I-beam size, beam must be free of all obstructions, such as clips, suspension bolts, and nuts. Trolleys for wide flange beams refer to Optional Equipment.

Trolley beam size range – beam flange width 4" min., 6-1/4" max; beam depth 8" min. standard, 6-3/8"-8-5/8" with 1st extension, 8-3/4"-11" with 2nd extension. See Optional Price section for extension pricing.

① Occurs on smallest beam size only. On larger beams, it is increased by the difference in flange width.

② Clearance shown is between lug and wheel tread.

③ Dimension increases 3" when hoist is equipped with screw type limit switch.

* Estimated wheel load per one (1) wheel. Includes live and dead load impacts.

Single Reeved

10 Ton

ELECTRIC WIRE ROPE

700 Series
Size 2

MOTOR DRIVEN TROLLEY

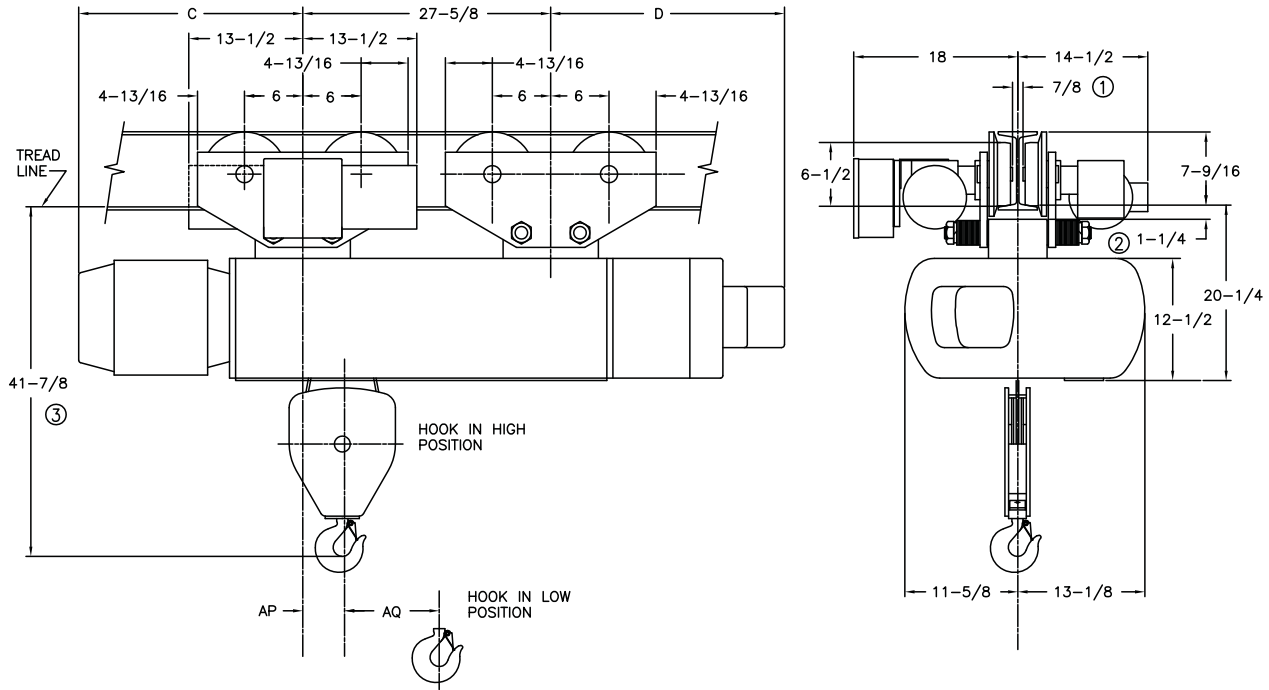

MINIMUM RADIUS: Straight Track ④

CATALOG NUMBER	HOIST				TROLLEY		WEIGHT (LBS)	C	D	AP	AQ	ESTIMATED WHEEL LOAD*	
	MAX LIFT (FT)	HOIST SPEED (FPM)	HP	ROPE NO & DIA	SPEED (FPM)	HP						HIGH HOOK (LBS)	LOW HOOK (LBS)
72M10-025S14-1	25	14	10	6-7/16	50	2 (1/4)	1785	19-7/8	23-7/8	2-5/8	5-3/4	5449	4252
72M10-025S14-2	25	14/4.6	10/3.3	6-7/16	50	2 (1/4)	1805	23-7/8	23-7/8	2-5/8	5-3/4	5452	4255

Weights shown are for standard hoists listed. For approximate shipping weights, add 110 lbs. to the net weight given. Consult factory for weights of special hoists. Dimensions shown are in inches unless otherwise noted.

When used on smallest I-beam size, beam must be free of all obstructions, such as clips, suspension bolts, and nuts. Trolleys for wide flange beams refer to Optional Equipment.

Trolley beam size range – beam flange width 4" min., 6-1/4" max; beam depth 8" min. standard, 6-3/8"-8-5/8" with 1st extension, 8-3/4"-11" with 2nd extension. See Optional Price section for extension pricing.

- ① Occurs on smallest beam size only. On larger beams, it is increased by the difference in flange width.
- ② Clearance shown is between lug and wheel tread.
- ③ Dimension increases 3" when hoist is equipped with screw type limit switch.
- ④ Can negotiate curves with addition of swivel trolley from the option pricing section. Headroom increases by 4-5/8".

* Estimated wheel load per one (1) wheel. Includes live and dead load impacts.

Standard Features

Dimensions & Specifications

ELECTRIC WIRE ROPE

**700 Series
Size 2**

Double Reeved Electric Hoists with Motor Driven Trolleys

Feature	1 Ton	3 Ton	5 Ton	7½ Ton
Service Class	H-4	H-4	H-4	H-4
Reeved	4 PD - 3/16"	4 PD - 5/16"	6 PD - 5/16"	8 PD - 5/16"
Hoist Gearing	Double Reduction Helical Gearing	Double Reduction Helical Gearing	Double Reduction Helical Gearing	Double Reduction Helical Gearing
Hook Assembly	Bearing-mounted 360 degree rotate	Bearing-mounted 360 degree rotate	Bearing-mounted 360 degree rotate	Bearing-mounted 360 degree rotate
Hoist Motor	30-minute rated TENV	30-minute rated TENV	30-minute rated TENV	30-minute rated TENV
Hoist Motor Brake	100% Torque DC disc	100% Torque DC disc	100% Torque DC disc	100% Torque DC disc
Load Brake	Weston type	Weston type	Weston type	Weston type
Hoist Control	1-speed	1-speed	1-speed	1-speed
Control Circuit voltage	115 Volts	115 Volts	115 Volts	115 Volts
Hoist Limit Switch	Upper block control circuit	Upper block control circuit	Upper block control circuit	Upper block control circuit
Rope Drum Diameter	9"	9"	9"	9"
Rope Drum Material	Cast Iron	Cast Iron	Cast Iron	Cast Iron
Sheave Diameter	9"	9"	9"	9"
Sheave Material	Cast Iron	Cast Iron	Cast Iron	Cast Iron
Trolley Gearing	Worm	Worm	Worm	Worm
Trolley Motor	30-minute rated TENV	30-minute rated TENV	30-minute rated TENV	30-minute rated TENV
Trolley Brake	Optional AC Disc	Optional AC Disc	Optional AC Disc	Optional AC Disc
Trolley Control	1-speed	1-speed	1-speed	1-speed
Wheels	6-1/2"	6-1/2"	6-1/2"	6-1/2"
Bumpers	Optional Rubber	Optional Rubber	Optional Rubber	Optional Rubber
Bearings	Anti-friction	Anti-friction	Anti-friction	Anti-friction
Motor TAS	Standard	Standard	Standard	Standard
Control Enclosure	NEMA 1	NEMA 1	NEMA 1	NEMA 1

**True
Vertical Lift**

1 Ton

ELECTRIC WIRE ROPE

**700 Series
Size 2**

For 83' Lift

Contact Factory for Dimensions

**True
Vertical Lift**

3 Ton

ELECTRIC WIRE ROPE

**700 Series
Size 2**

MOTOR DRIVEN TROLLEY

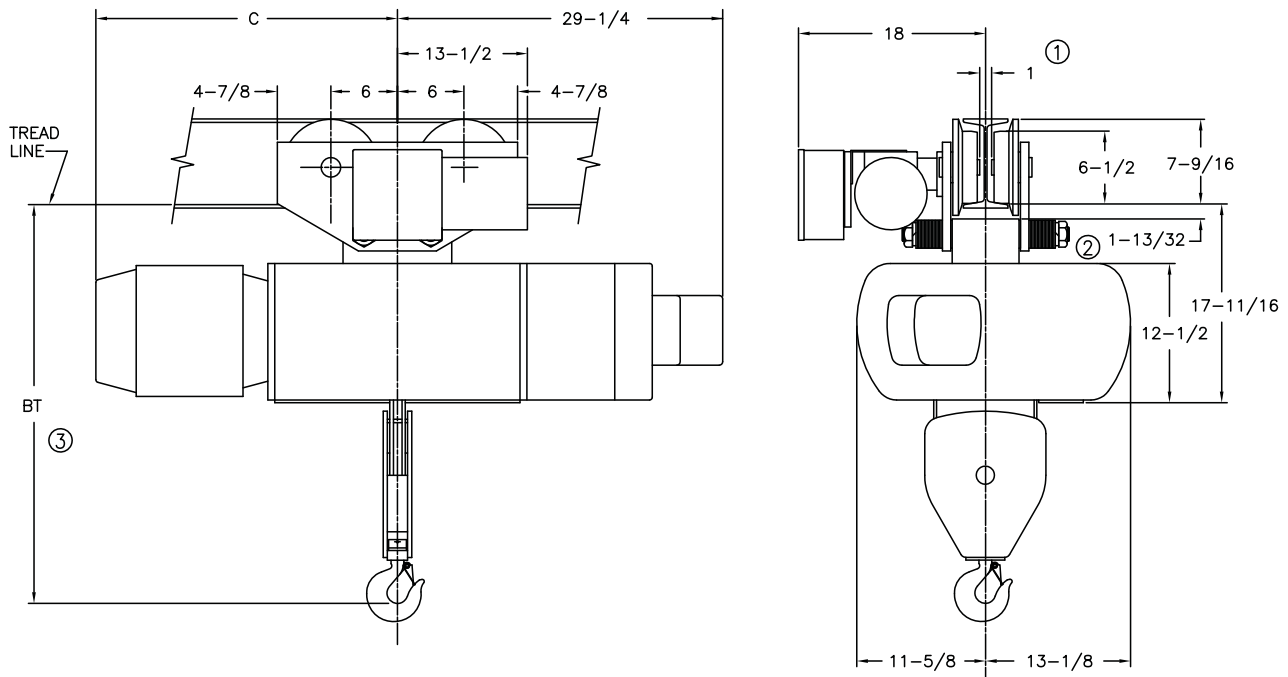

MINIMUM STANDARD RADIUS: 7'-0", FOR SMALLER RADIUS CONTACT FACTORY

CATALOG NUMBER	HOIST				TROLLEY		WEIGHT (LBS)	C	BT	ESTIMATED WHEEL LOAD* (LBS)
	MAX LIFT (FT)	HOIST SPEED (FPM)	HP	ROPE NO & DIA	SPEED (FPM)	HP				
72M03-027D19-1	27	19	5	4/2-5/16	50	1/2	1030	24	29-5/8	2008
72M03-027D19-2	27	19/7	5/1.88	4/2-5/16	50	1/2	1080	29-1/8	29-5/8	2022
72M03-027D30-1	27	30	7.5	4/2-5/16	50	1/2	1030	26-3/4	32-5/8	2008
72M03-027D30-2	27	30/10	7.5/2.5	4/2-5/16	50	1/2	1080	29-1/4	32-5/8	2022
72M03-027D40-1	27	40	10	4/2-5/16	50	1/2	1030	26-1/8	32-5/8	2083
72M03-027D40-2	27	40/13	10/3.3	4/2-5/16	50	1/2	1080	30-1/8	32-5/8	2097

Weights shown are for standard hoists listed. For approximate shipping weights, add 110 lbs. to the net weight given. Consult factory for weights of special hoists. Dimensions shown are in inches unless otherwise noted.

When used on smallest I-beam size, beam must be free of all obstructions, such as clips, suspension bolts, and nuts. Trolleys for wide flange beams refer to Optional Equipment.

Trolley beam size range – beam flange width 4" min., 6-1/4" max; beam depth 8" min. standard, 6-3/8"-8-5/8" with 1st extension, 8-3/4"-11" with 2nd extension. See Optional Price section for extension pricing.

- ① Occurs on smallest beam size only. On larger beams, it is increased by the difference in flange width.
- ② Clearance shown is between lug and wheel tread.
- ③ Dimension increases 3" when hoist is equipped with screw type limit switch, except on hoists with a 32-5/8" BT dimension. These are provided with a screw and block control circuit limit switch as standard.

* Estimated wheel load per one (1) wheel. Includes live and dead load impacts.

**True
Vertical Lift**

3 Ton

ELECTRIC WIRE ROPE

**700 Series
Size 2**

MOTOR DRIVEN TROLLEY

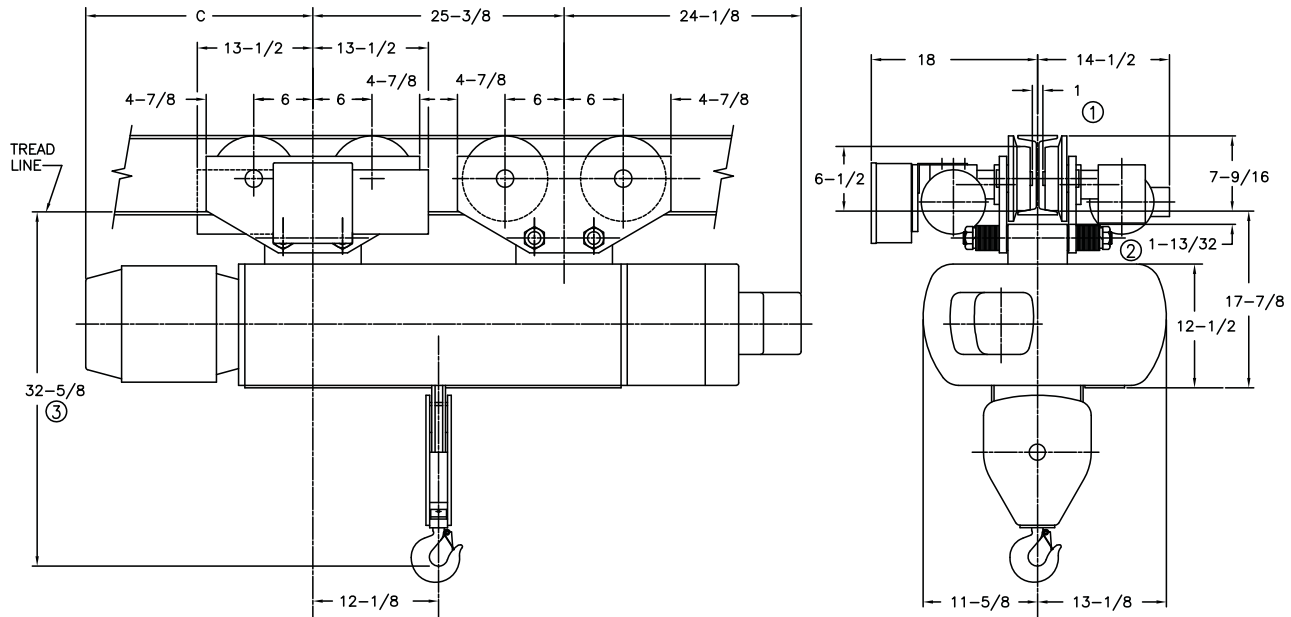

MINIMUM RADIUS: Straight Track ④

CATALOG NUMBER	HOIST				TROLLEY		WEIGHT (LBS)	C	ESTIMATED WHEEL LOAD* (LBS)
	MAX LIFT (FT)	HOIST SPEED (FPM)	HP	ROPE NO & DIA	SPEED (FPM)	HP			
72M03-050D19-1	50	19	5	4/2-5/16	50	(2) 1/4	1605	19-3/4	1083
72M03-050D19-2	50	19/7	5/1.88	4/2-5/16	50	(2) 1/4	1630	24-7/8	1087
72M03-050D30-1	50	30	7.5	4/2-5/16	50	(2) 1/4	1605	22-1/2	1083
72M03-050D30-2	50	30/10	7.5/2.5	4/2-5/16	50	(2) 1/4	1630	24-7/8	1087
72M03-050D40-1	50	40	10	4/2-5/16	50	(2) 1/4	1605	21-7/8	1121
72M03-050D40-2	50	40/13	10/3.3	4/2-5/16	50	(2) 1/4	1630	25-5/8	1124

Weights shown are for standard hoists listed. For approximate shipping weights, add 110 lbs. to the net weight given. Consult factory for weights of special hoists. Dimensions shown are in inches unless otherwise noted.

When used on smallest I-beam size, beam must be free of all obstructions, such as clips, suspension bolts, and nuts. Trolleys for wide flange beams refer to Optional Equipment.

Trolley beam size range – beam flange width 4" min., 6-1/4" max; beam depth 8" min. standard, 6-3/8"-8-5/8" with 1st extension, 8-3/4"-11" with 2nd extension. See Optional Price section for extension pricing.

① Occurs on smallest beam size only. On larger beams, it is increased by the difference in flange width.

② Clearance shown is between lug and wheel tread.

③ Hoist is equipped with block and screw type control circuit limit switches

④ Can negotiate curves with addition of swivel trolley option from pricing section. Headroom increases by 4-5/8".

* Estimated wheel load per one (1) wheel. Includes live and dead load impacts.

**True
Vertical Lift**

5 Ton

ELECTRIC WIRE ROPE

**700 Series
Size 2**

MOTOR DRIVEN TROLLEY

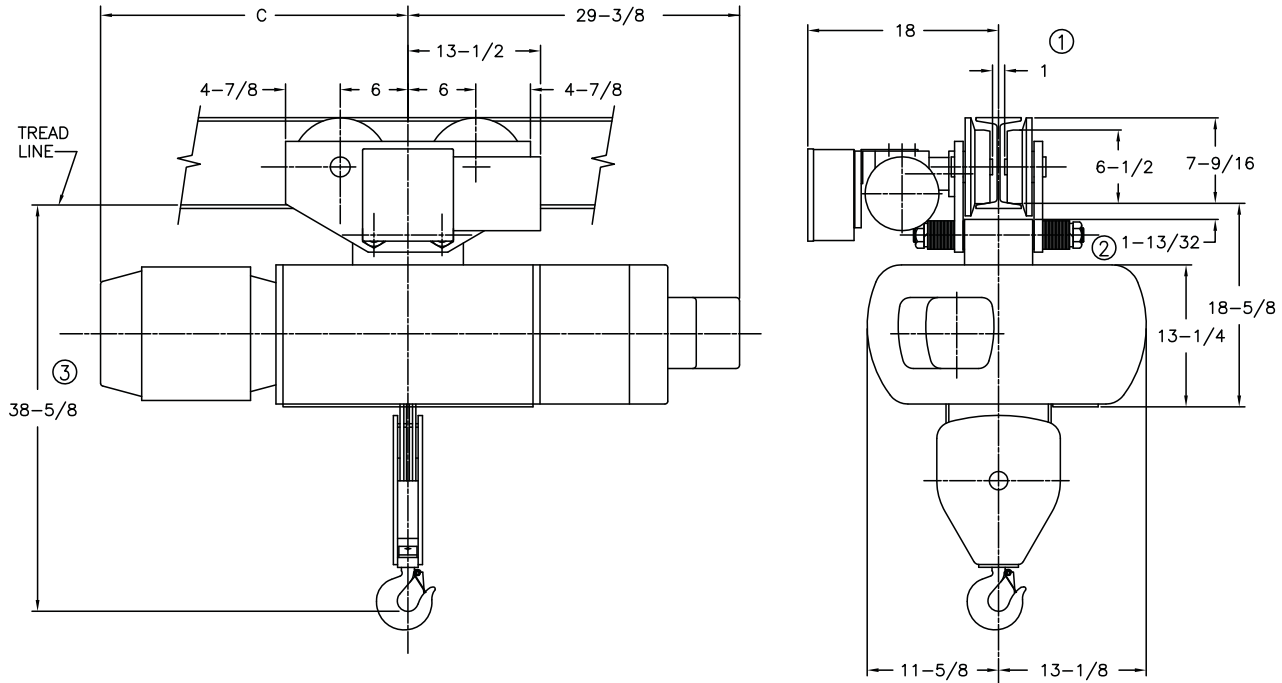

MINIMUM STANDARD RADIUS: 7'-0", FOR SMALLER RADIUS CONTACT FACTORY

CATALOG NUMBER	HOIST				TROLLEY		WEIGHT (LBS)	C	ESTIMATED WHEEL LOAD* (LBS)
	MAX LIFT (FT)	HOIST SPEED (FPM)	HP	ROPE NO & DIA	SPEED (FPM)	HP			
72M05-018D13-1	18	13	5	6/2-5/16	50	1/2	1050	23-7/8	3164
72M05-018D13-2	18	13/4.3	5/1.88	6/2-5/16	50	1/2	1110	29	3180
72M05-018D19-1	18	19	7.5	6/2-5/16	50	1/2	1100	26-5/8	3178
72M05-018D19-2	18	19/6	7.5/2.5	6/2-5/16	50	1/2	1150	29	3191
72M05-018D27-1	18	27	10	6/2-5/16	50	1/2	1100	26	3178
72M05-018D27-2	18	27/9	10/3.3	6/2-5/16	50	1/2	1150	29-3/4	3191

Weights shown are for standard hoists listed. For approximate shipping weights, add 110 lbs. to the net weight given. Consult factory for weights of special hoists. Dimensions shown are in inches unless otherwise noted.

When used on smallest I-beam size, beam must be free of all obstructions, such as clips, suspension bolts, and nuts. Trolleys for wide flange beams refer to Optional Equipment.

Trolley beam size range – beam flange width 4" min., 6-1/4" max; beam depth 8" min. standard, 6-3/8"-8-5/8" with 1st extension, 8-3/4"-11" with 2nd extension. See Optional Price section for extension pricing.

① Occurs on smallest beam size only. On larger beams, it is increased by the difference in flange width.

② Clearance shown is between lug and wheel tread.

③ Dimension increases 3" when hoist is equipped with screw type limit switch.

* Estimated wheel load per one (1) wheel. Includes live and dead load impacts.

True Vertical Lift

5 Ton

ELECTRIC WIRE ROPE

700 Series Size 2

MOTOR DRIVEN TROLLEY

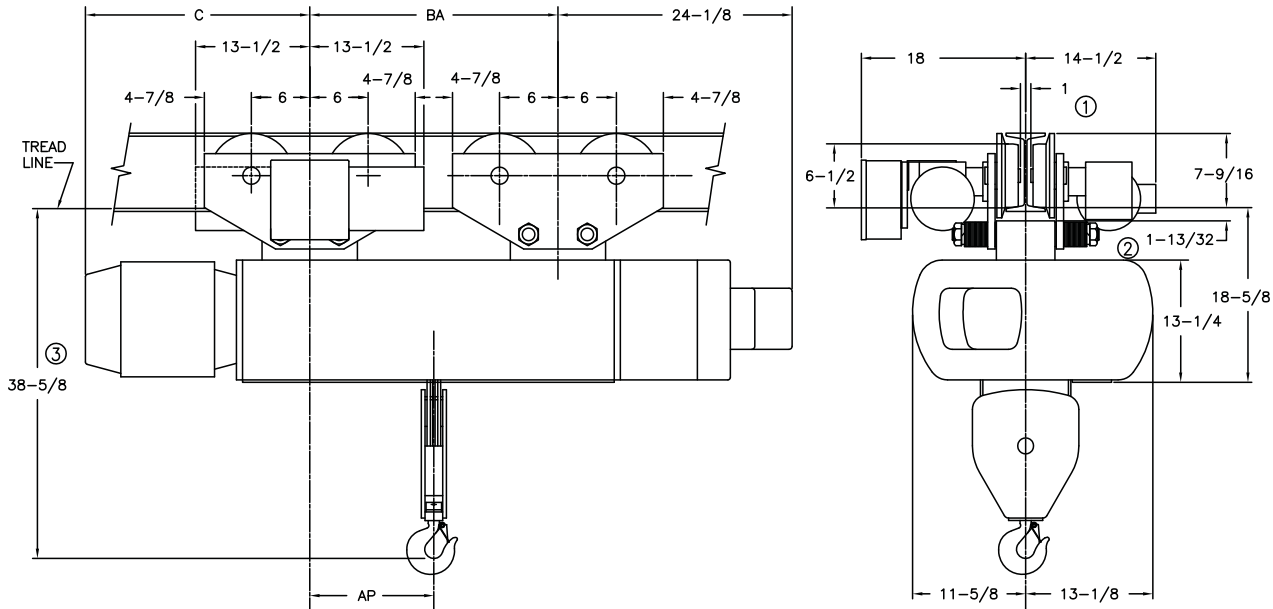

MINIMUM RADIUS: Straight Track ④

CATALOG NUMBER	HOIST				TROLLEY		WEIGHT (LBS)	C	BA	AP	ESTIMATED WHEEL LOAD* (LBS)
	MAX LIFT (FT)	HOIST SPEED (FPM)	HP	ROPE NO & DIA	SPEED (FPM)	HP					
72M05-035D13-1	35	13	5	6/2-5/16	50	(2) 1/4	1635	19-3/4	25-3/8	12-1/8	1662
72M05-035D13-2	35	13/4.3	5/1.88	6/2-5/16	50	(2) 1/4	1665	24-7/8	25-3/8	12-1/8	1666
72M05-035D19-1	35	19	7.5	6/2-5/16	50	(2) 1/4	1685	22-1/2	25-3/8	12-1/8	1669
72M05-035D19-2	35	19/6	7.5/2.5	6/2-5/16	50	(2) 1/4	1705	24-7/8	25-3/8	12-1/8	1672
72M05-035D27-1	35	27	10	6/2-5/16	50	(2) 1/4	1685	21-7/8	25-3/8	12-1/8	1669
72M05-035D27-2	35	27/9	10/3.3	6/2-5/16	50	(2) 1/4	1705	25-5/8	25-3/8	12-1/8	1672

Weights shown are for standard hoists listed. For approximate shipping weights, add 110 lbs. to the net weight given. Consult factory for weights of special hoists. Dimensions shown are in inches unless otherwise noted.

When used on smallest I-beam size, beam must be free of all obstructions, such as clips, suspension bolts, and nuts. Trolleys for wide flange beams refer to Optional Equipment.

Trolley beam size range – beam flange width 4" min., 6-1/4" max; beam depth 8" min. standard, 6-3/8"-8-5/8" with 1st extension, 8-3/4"-11" with 2nd extension. See Optional Price section for extension pricing.

① Occurs on smallest beam size only. On larger beams, it is increased by the difference in flange width.

② Clearance shown is between lug and wheel tread.

③ Dimension increases 3" when hoist is equipped with screw type limit switch.

NOTE: Increases on the 56 foot lift hoists only which are equipped with screw and block type limit switches.

④ Can negotiate curves with addition of swivel trolley from the option pricing section. Headroom increases by 4-5/8".

* Estimated wheel load per one (1) wheel. Includes live and dead load impacts.

**True
Vertical Lift**

7½ Ton

ELECTRIC WIRE ROPE

**700 Series
Size 2**

MOTOR DRIVEN TROLLEY

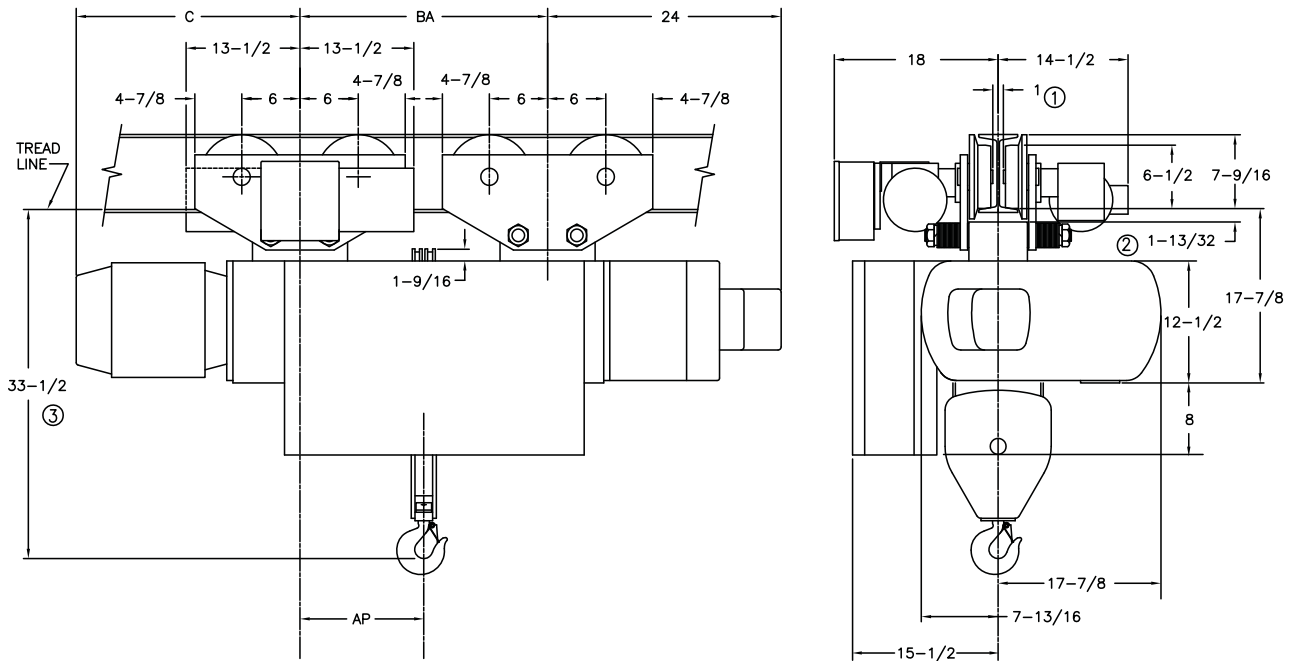

MINIMUM RADIUS: Straight Track ④

CATALOG NUMBER	HOIST				TROLLEY		WEIGHT (LBS)	C	BA	AP	ESTIMATED WHEEL LOAD* (LBS)
	MAX LIFT (FT)	HOIST SPEED (FPM)	HP	ROPE NO & DIA	SPEED (FPM)	HP					
72M07-023D14-1	23	14	7.5	8/2-5/16	50	(2) 1/4	1685	21-1/4	27-1/4	13-5/8	2389
72M07-023D14-2	23	14/5	7.5/2.5	8/2-5/16	50	(2) 1/4	1705	23-1/2	27-1/4	13-5/8	2391

Weights shown are for standard hoists listed. For approximate shipping weights, add 110 lbs. to the net weight given. Consult factory for weights of special hoists. Dimensions shown are in inches unless otherwise noted.

When used on smallest I-beam size, beam must be free of all obstructions, such as clips, suspension bolts, and nuts. Trolleys for wide flange beams refer to Optional Equipment.

Trolley beam size range – beam flange width 4" min., 6-1/4" max; beam depth 8" min. standard, 6-3/8"-8-5/8" with 1st extension, 8-3/4"-11" with 2nd extension. See Optional Price section for extension pricing.

① Occurs on smallest beam size only. On larger beams, it is increased by the difference in flange width.

② Clearances shown is between lug and wheel tread.

③ Dimension increases 3" when hoist is equipped with screw type limit switch.

④ Can negotiate curves with addition of swivel trolley option from pricing section. Increases headroom by 4-5/8".

* Estimated wheel load per one (1) wheel. Includes live and dead load impacts.

Standard Features

Dimensions & Specifications

ELECTRIC WIRE ROPE

700 Series
Size 2

Shaw-Box Single Reeved Deck Hoist

Feature	700 Series
	Size 2
Tons Capacity	3, 5, 7.5 & 10
Service Class	HMI - Class H4
Reeved	Single or Double
Rope Guide	No
Hoist Gearing	Helical in oil bath
Hoist Load Brake	Mechanical
Hoist Motor	One or two speed squirrel cage with TAS Two speed is 3:1 ratio 30 minute duty Class F insulation TENV
Hoist Motor Brake	DC disc
Hoist Limit Switch	"Block upper, geared U/L"
Hoist Control	"Magnetic contactor 1-speed standard"
Bearings	Anti-friction throughout
Motor TAS	Standard
Control Enclosure	NEMA 4/12

All panels ship loose as standard with leads pulled to a J-box, except for the World Series which is mounted and wired as a standard.

Deck Mounted

3 Ton

ELECTRIC WIRE ROPE

**700 Series
Size 2**

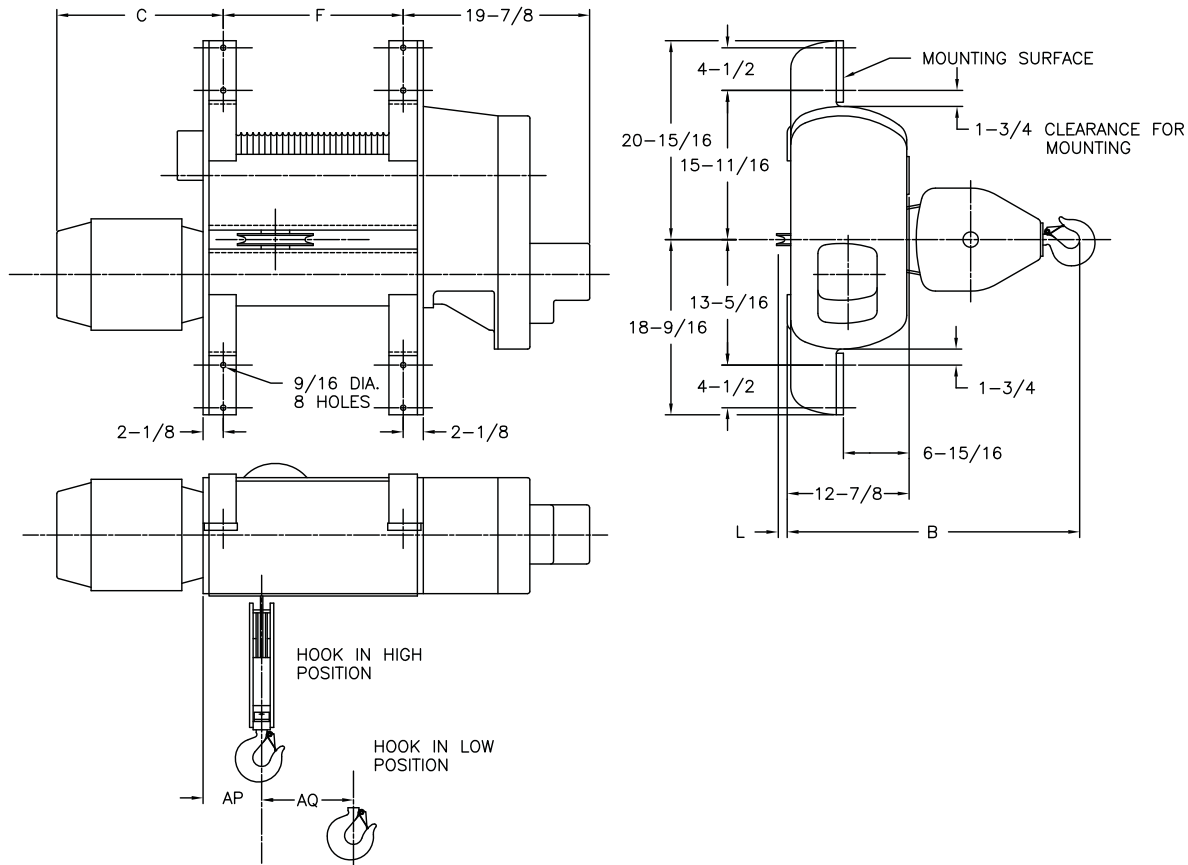

CATALOG NUMBER	HOIST				WEIGHT (LBS)	B	C	F	L	AP	AQ
	MAX LIFT (FT)	HOIST SPEED (FPM)	HP	ROPE NO & DIA							
72D03-026S15-1	26	15	3	4-3/8	870	36	14-5/8	19	1-1/8	6-7/8	5
72D03-026S15-2	26	15/5	3/1	4-3/8	895	36	19-3/4	19	1-1/8	6-7/8	5
72D03-026S20-1	26	20	5	4-3/8	885	36	14-5/8	19	1-1/8	6-7/8	5
72D03-026S20-2	26	20/7	5/1.6	4-3/8	945	36	19-3/4	19	1-1/8	6-7/8	5
72D03-044S30-1	44	30	7.5	2-7/16	865	33-7/8	17-3/4	19	-	6-1/8	9-15/16
72D03-044S30-2	44	30/10	7.5/2.5	2-7/16	915	33-7/8	20-3/8	19	-	6-1/8	9-15/16
72D03-044S40-1	44	40	7.5	2-7/16	865	33-7/8	17-1/4	19	-	6-1/8	9-15/16
72D03-044S40-2	44	40/13	7.5/2.5	2-7/16	915	33-7/8	20-3/8	19	-	6-1/8	9-15/16

Weights shown are for standard hoists listed. For approximate shipping weights, add 110 lbs. to the net weight given. Consult factory for weights of special hoists. Dimensions shown are in inches unless otherwise noted.

Deck Mounted

3 Ton

ELECTRIC WIRE ROPE

**700 Series
Size 2**

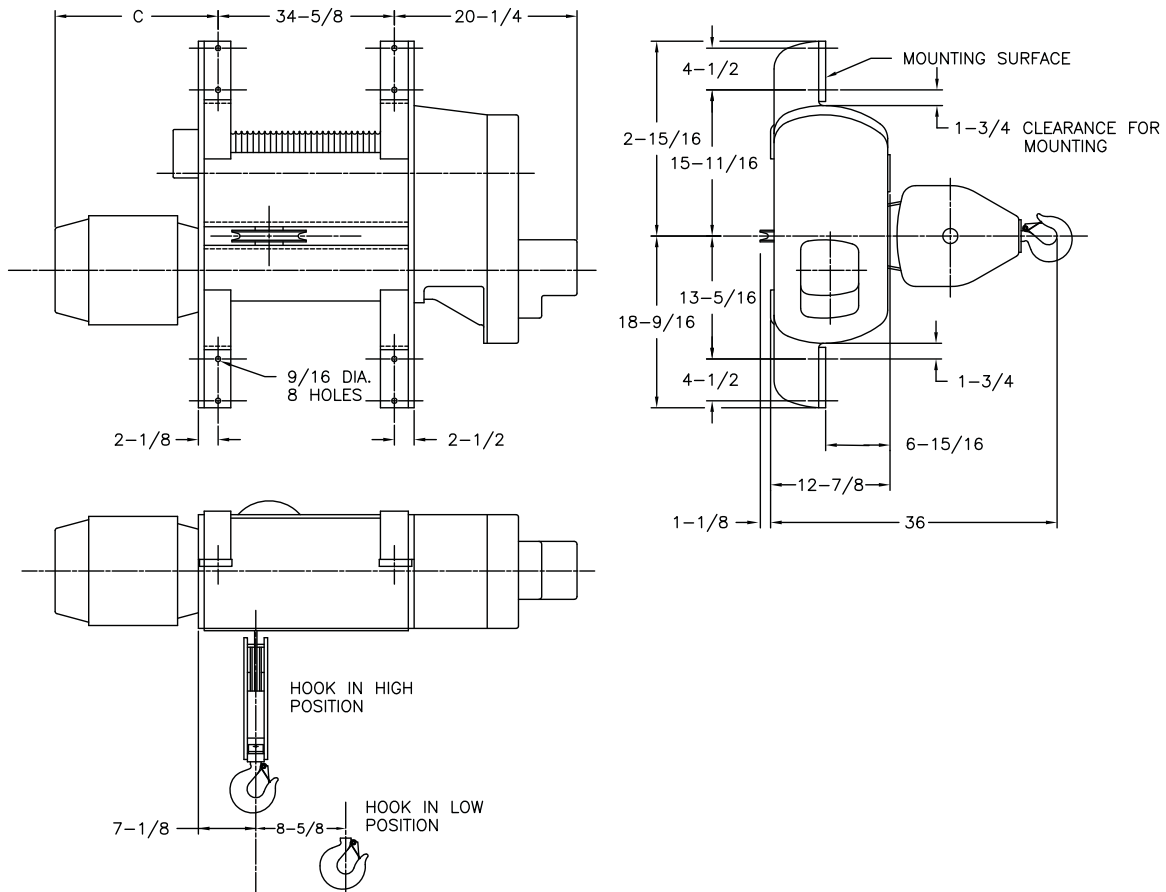

CATALOG NUMBER	HOIST				WEIGHT (LBS)	C
	MAX LIFT (FT)	HOIST SPEED (FPM)	HP	ROPE NO & DIA		
72D03-055S30-1	55	30	7.5	4-5/16	1255	17-1/4
72D03-055S30-2	55	30/10	7.5/2.5	4-5/16	1280	20-3/8

Weights shown are for standard hoists listed. For approximate shipping weights, add 110 lbs. to the net weight given. Consult factory for weights of special hoists. Dimensions shown are in inches unless otherwise noted.

Deck Mounted

5 Ton

ELECTRIC WIRE ROPE

**700 Series
Size 2**

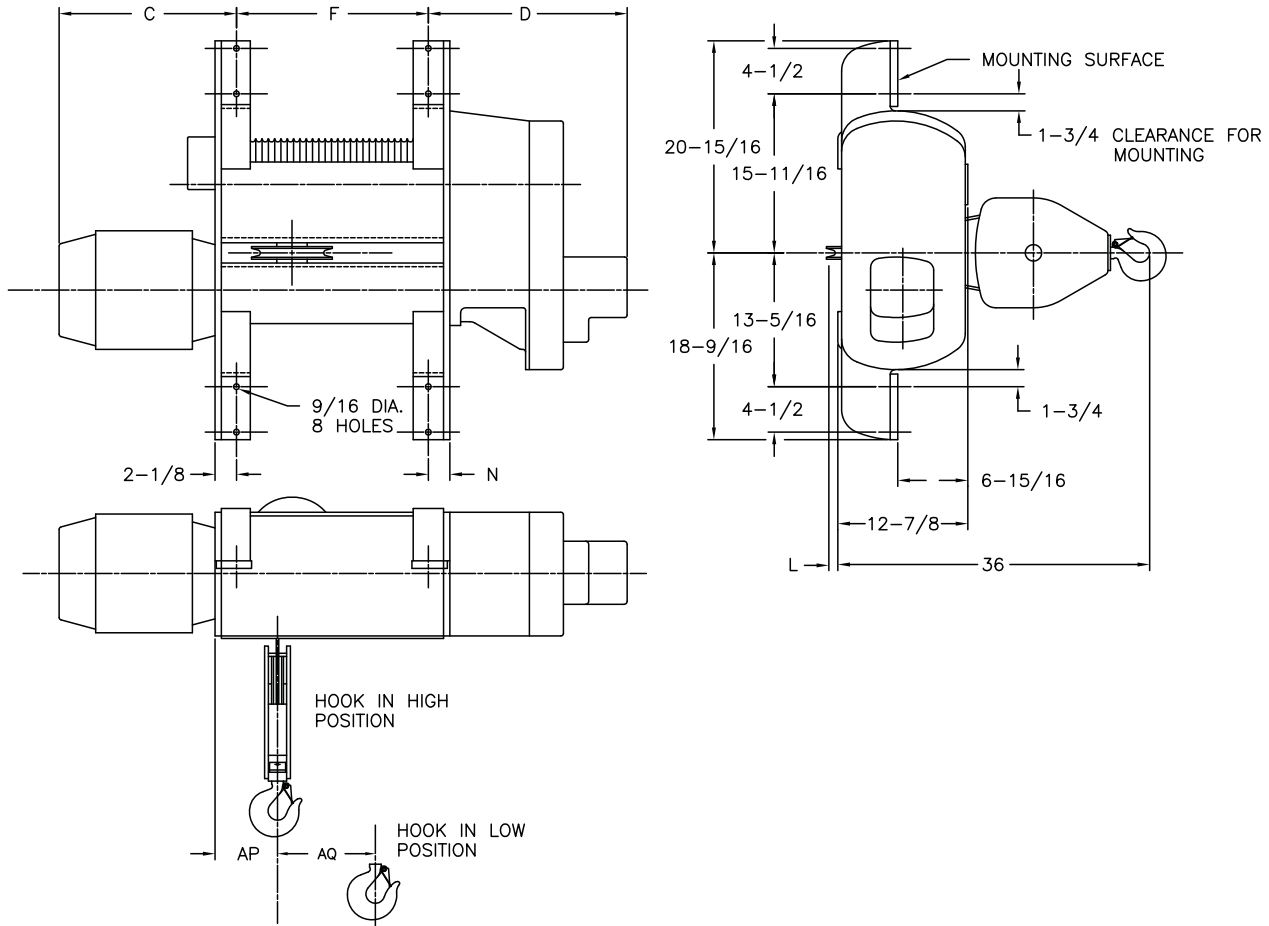

CATALOG NUMBER	HOIST				WEIGHT (LBS)	C	D	F	L	N	AP	AQ
	MAX LIFT (FT)	HOIST SPEED (FPM)	HP	ROPE NO & DIA								
72D05-026S15-1	26	15	5	4-3/8	885	14-5/8	20	19	1-1/8	2-1/8	7	4-7/8
72D05-026S15-2	26	15/5	5/1.6	4-3/8	945	19-3/4	20	19	1-1/8	2-1/8	7	4-7/8
72D05-026S20-1	26	20	7.5	4-3/8	935	17-1/8	20	19	1-1/8	2-1/8	7	4-7/8
72D05-026S20-2	26	20/7	7.5/2.5	4-3/8	985	20-3/8	20	19	1-1/8	2-1/8	7	4-7/8
72D05-047S20-1	47	20	7.5	4-3/8	1255	17-1/8	20-1/4	34-5/8	1-1/8	2-1/2	7-1/2	8-3/4
72D05-047S20-2	47	20/7	7.5/2.5	4-3/8	1280	20-3/8	20-1/4	34-5/8	1-1/8	2-1/2	7-1/2	8-3/4

Weights shown are for standard hoists listed. For approximate shipping weights, add 110 lbs. to the net weight given. Consult factory for weights of special hoists. Dimensions shown are in inches unless otherwise noted.

Deck Mounted

7½ Ton

ELECTRIC WIRE ROPE

**700 Series
Size 2**

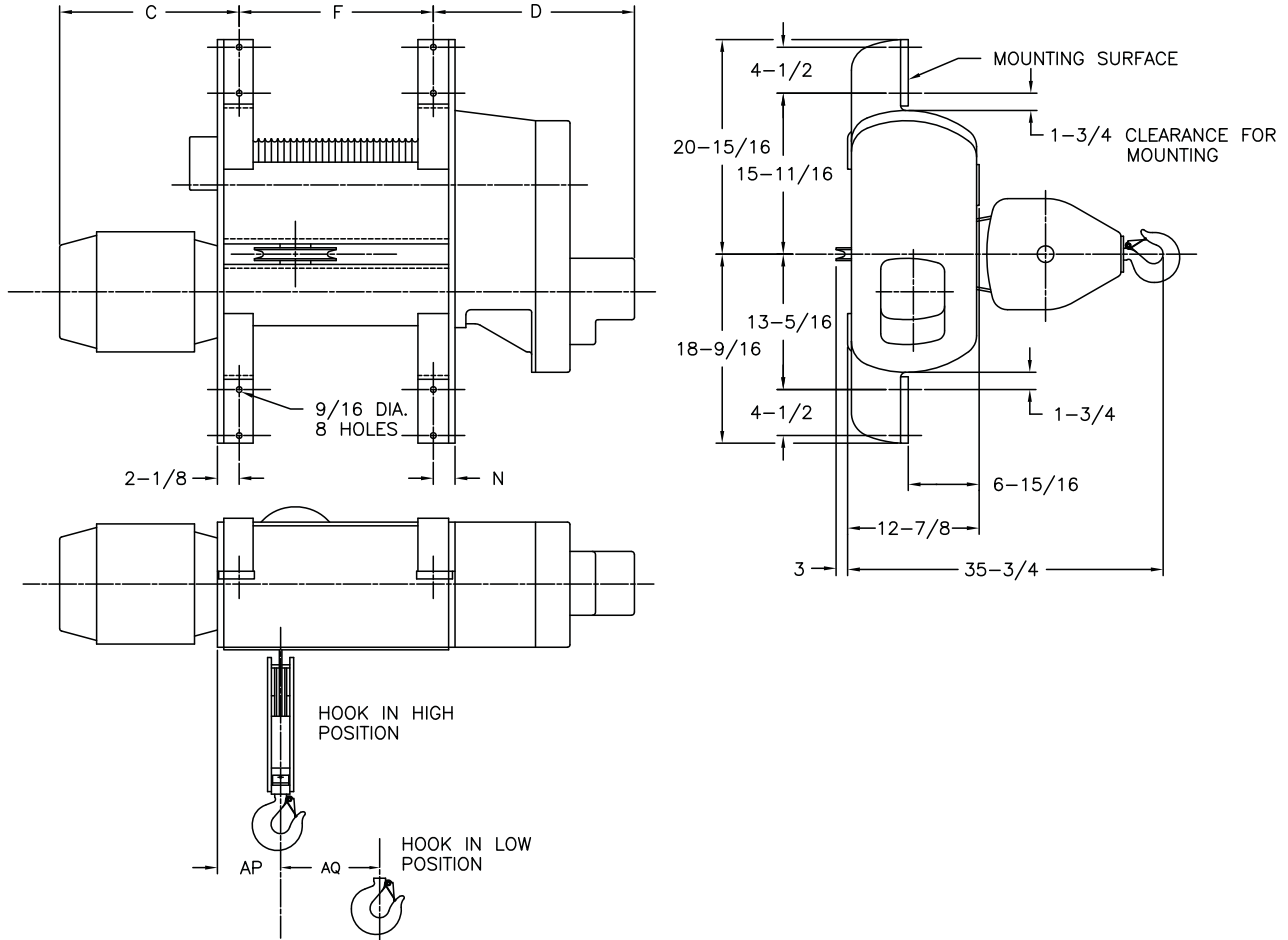

CATALOG NUMBER	HOIST				WEIGHT (LBS)	C	D	F	L	N	AP	AQ
	MAX LIFT (FT)	HOIST SPEED (FPM)	HP	ROPE NO & DIA								
72D07-012S14-2	12	14/5	7.5/2.5	4-7/16	860	20-3/8	19-7/8	10	2	2-1/8	6-7/8	2-9/16
72D07-022S14-1	22	14	7.5	4-7/16	935	17-1/8	19-7/8	19	1-1/8	2-1/8	7-1/8	4-3/4
72D07-038S14-1	38	14	7.5	4-7/16	1250	17-1/8	20-1/4	34-5/8	1-1/8	2-1/2	7-3/8	8-1/2
72D07-038S14-2	38	14/5	7.5/2.5	4-7/16	1275	20-3/8	20-1/4	34-5/8	1-1/8	2-1/2	7-3/8	8-1/2

Weights shown are for standard hoists listed. For approximate shipping weights, add 110 lbs. to the net weight given. Consult factory for weights of special hoists. Dimensions shown are in inches unless otherwise noted.

Deck Mounted

10 Ton

ELECTRIC WIRE ROPE

**700 Series
Size 2**

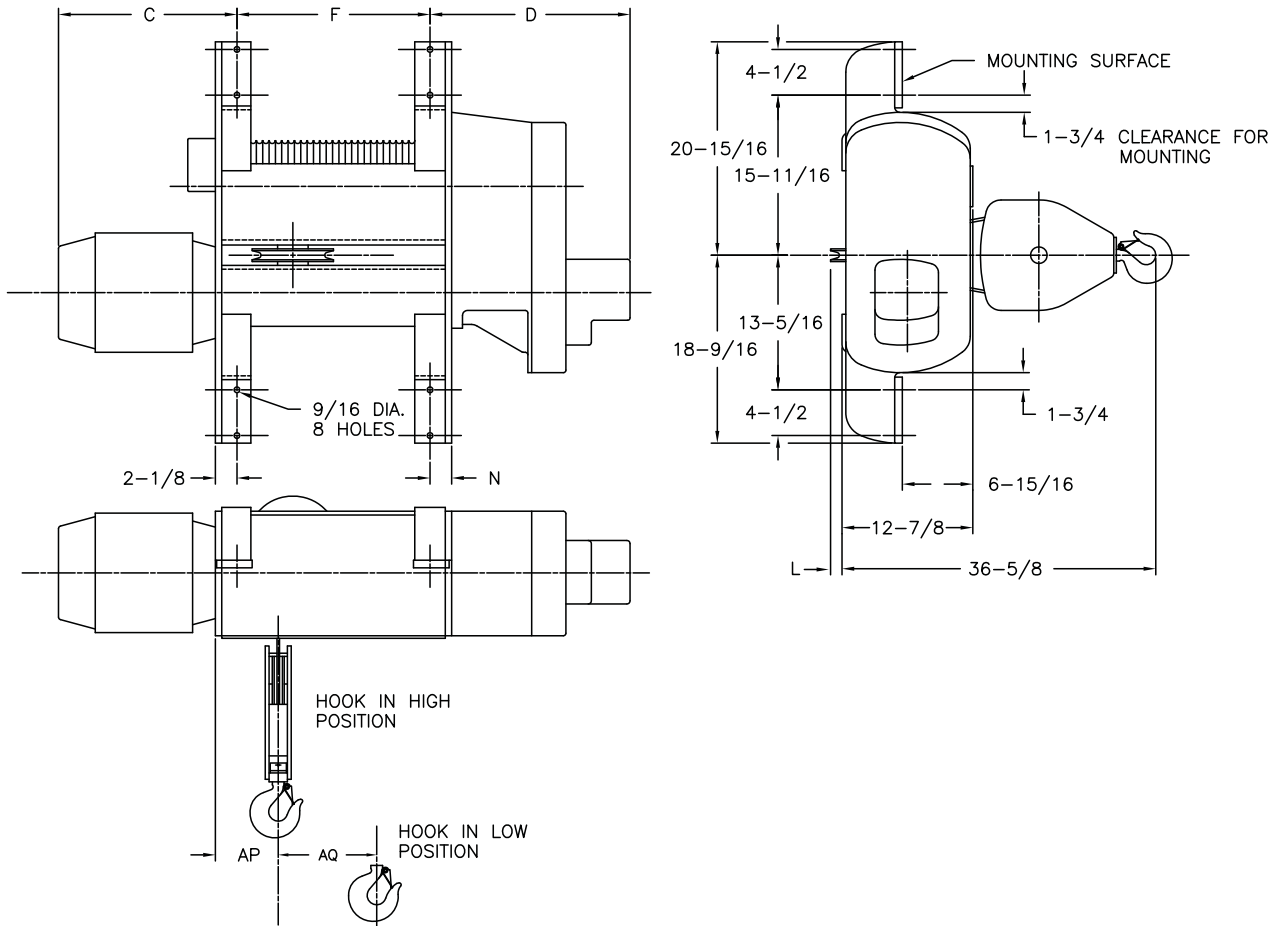

CATALOG NUMBER	HOIST				WEIGHT (LBS)	C	D	F	N	AP	AQ
	MAX LIFT (FT)	HOIST SPEED (FPM)	HP	ROPE NO & DIA							
72D10-015S14-1	15	14	10	6-7/16	1035	16-3/8	20	19	2-1/8	7-3/16	3-1/8
72D10-015S14-2	15	14/4.6	10/3.3	6-7/16	1085	20-3/8	20	19	2-1/8	7-3/16	3-1/8
72D10-025S14-1	25	14	10	6-7/16	1350	16-3/8	20-1/4	34-5/8	2-1/2	8-7/8	5-9/16
72D10-025S14-2	25	14/4.6	10/3.3	6-7/16	1375	20-3/8	20-1/4	34-5/8	2-1/2	8-7/8	5-9/16
72D10-040S14-1	40	14	10	6-7/16	1650	16-3/8	20-3/8	55-1/8	2-1/2	8-7/8	9
72D10-040S14-2	40	14/4.6	10/3.3	6-7/16	1675	20-3/8	20-3/8	55-1/8	2-1/2	8-7/8	9

Weights shown are for standard hoists listed. For approximate shipping weights, add 110 lbs. to the net weight given. Consult factory for weights of special hoists. Dimensions shown are in inches unless otherwise noted.



Division of Columbus McKinnon Corporation

For Additional Information,
Contact Your Representative or Customer Service

Phone (800) 888.0985 • Fax (716) 698.5644
www.cmworks.com

⚠ WARNING

- To Avoid Injury:**
- Do not exceed working load limit, load rating, or capacity.
 - Do not use to lift people or loads over people.
 - Read and follow all instructions.