

TB Double Girder Trolleys - Single Reeved

Capacity	Page
5 Ton.....	YDG-2 - YDG-4
7½ Ton.....	YDG-5 - YDG-6
10 Ton.....	YDG-7 - YDG-9
15 Ton.....	YDG-10 - YDG-11
20 Ton.....	YDG-12

TB Double Girder Trolleys - Double Reeved

Capacity	Page
5 Ton.....	YDG-13 - YDG-15
7½ Ton.....	YDG-16 - YDG-19
10 Ton.....	YDG-20 - YDG-22
15 Ton.....	YDG-23 - YDG-25
20 Ton.....	YDG-26 - YDG-27

TR Double Girder Trolleys - Double Reeved

Capacity	Page
5 Ton.....	YDG-28 - YDG-30
7½ Ton.....	YDG-31 - YDG-35
10 Ton.....	YDG-36 - YDG-41
15 Ton.....	YDG-42 - YDG-45
20 Ton.....	YDG-46 - YDG-49
25 Ton.....	YDG-50 - YDG-52
30 Ton.....	YDG-53 - YDG-54
35 Ton.....	YDG-55

2 Part Single Reeving - S2 4 Part Single Reeving - S4

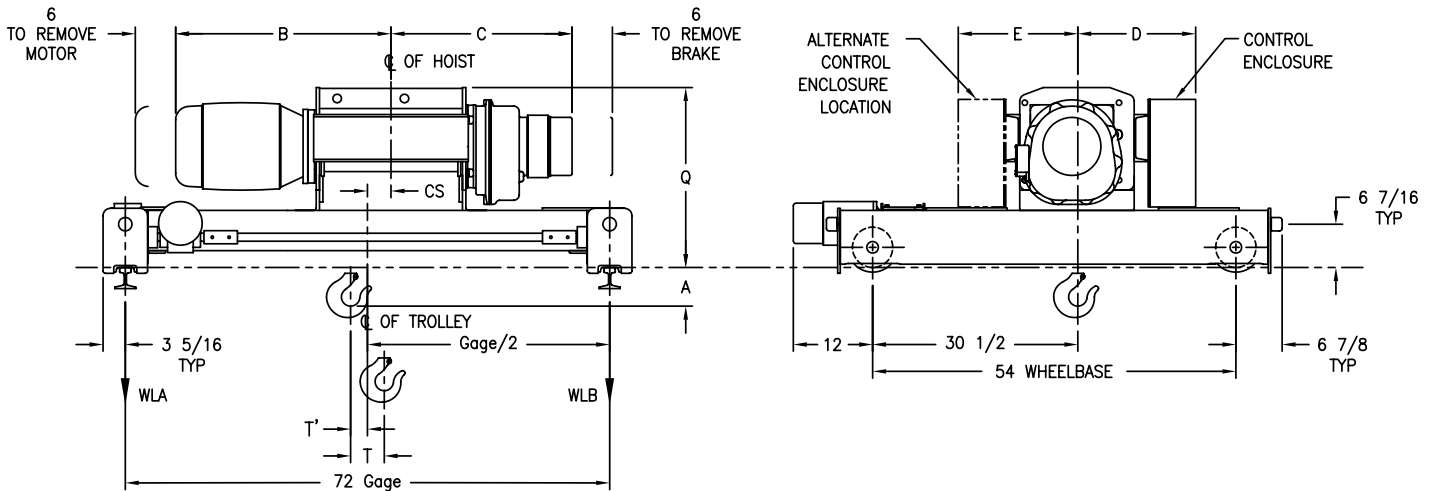

Drawing 23484201

Model Number	Lift (ft)	Speed fpm	Motor HP/RPM	Rope Dia.	Est Net Weight	WLA	WLB	A	B	C	D	E	CS	Q	T	T'	Max Rail Size (ASCE)	Wheel Tread Dia.
BEW5X19TB12S4	19	12	5-1800	3/8	1750	3533	3574	5-1/4	29	27	21	21	3-1/2	26-3/4	5	2-1/2	40#	6"
BEW5X19TB15S4	19	15	5-1800	3/8	1750	3533	3574	5-1/4	29	27	21	21	3-1/2	26-3/4	5	2-1/2	40#	6"
CEW5X19TB28S2	19	28	10-1800	1/2	1850	3593	3568	10	31	28	23	22	1/2	30	5	2-1/2	40#	6"
CEW5-21TB19S4	21	19	7.5-1800	3/8	1810	3567	3576	6-1/4	30	28	23	22	2-1/2	26-3/4	5	2-1/2	40#	6"
BEW5X26TB12S4	26	12	5-1800	3/8	1800	3538	3679	5-1/8	33	30	21	21	7	26-7/8	6	3	40#	6"
BEW5X26TB15S4	26	15	5-1800	3/8	1800	3538	3679	5-1/8	33	30	21	21	7	26-7/8	6	3	40#	6"
CEW5-30TB19S4	30	19	7.5-1800	3/8	1870	3593	3667	6-1/4	37	32	23	22	5	26-3/4	6	3	40#	6"
CEW5X32TB28S2	32	28	10-1800	1/2	1920	3597	3926	10	34	31	23	22	1-1/2	30	9	4-1/2	40#	6"

TB Trolley Speeds 45 & 60 fpm - 1/2 hp 1800 rpm
80 fpm - 1/2 hp 1200 rpm
90 & 120 fpm - 3/4 hp 1800 rpm

Additional lifts, speeds and non-rotating rope available, consult factory.
Yale reserves the right to make product changes as necessary.

2 Part Single Reeving - S2 4 Part Single Reeving - S4

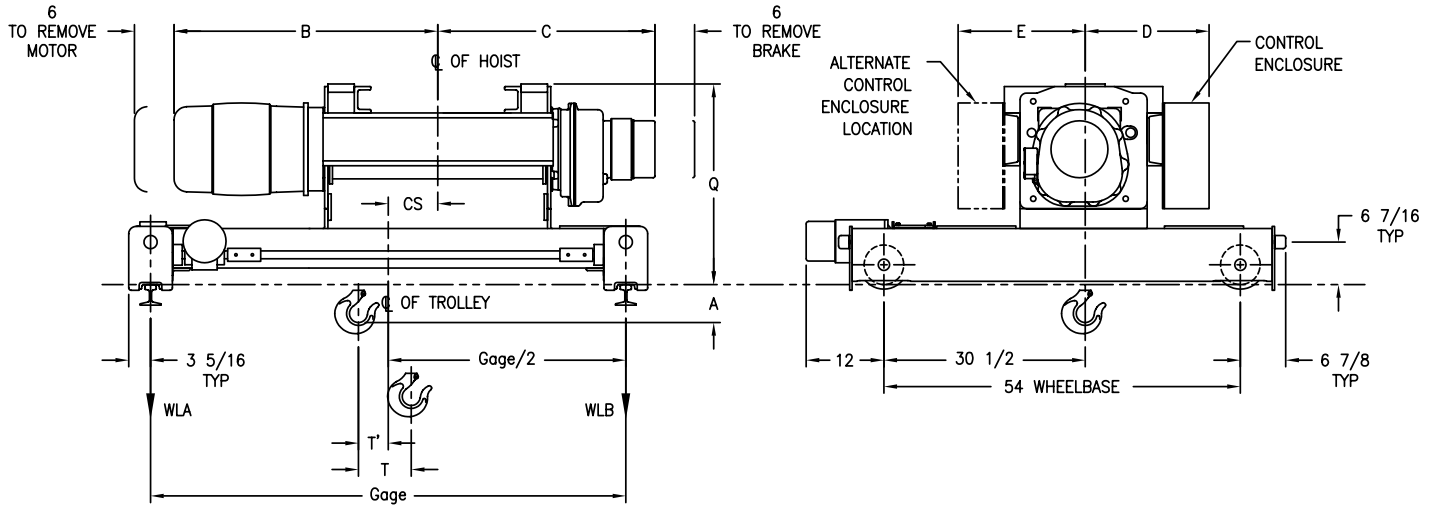

Drawing 23484202

Model Number	Lift (ft)	Speed fpm	Motor HP/RPM	Rope Dia.	Est Net Weight	WLA	WLB	A	B	C	D	E	CS	Q	T	T'	Gage Std.	Max Rail Size (ASCE)	Wheel Tread Dia.
BEW5X33TB12S4	33	12	5-1800	3/8	1860	3603	3718	4-7/8	33	35	21	21	9	27-1/8	8	4	84	40#	6"
BEW5X33TB15S4	33	15	5-1800	3/8	1860	3603	3718	4-7/8	33	35	21	21	9	27-1/8	8	4	84	40#	6"
CEW5-38TB19S4	38	19	7.5-1800	3/8	1900	3698	3740	6-1/8	40	35	23	22	7-1/2	26-7/8	8	4-1/2	72	40#	6"
BEW5X41TB15S4	41	15	5-1800	3/8	1930	3611	3744	4-7/8	37	39	21	21	11-1/2	27-1/8	9	4-1/2	96	40#	6"
CEW5X45TB28S2	45	28	10-1800	1/2	2070	3913	3941	10-5/8	37	34	23	22	2	30-3/8	12	6	72	40#	6"
CEW5-48TB19S4	48	19	7.5-1800	3/8	2030	3667	3827	6-1/8	43	39	23	22	10-1/2	26-7/8	9	4-1/2	84	40#	6"
CEW5X57TB16S2	57	16	7.5-1200	1/2	2120	4031	4093	10-5/8	40	37	23	22	3-1/2	30-3/8	15	7-1/2	72	40#	6"
CEW5X57TB28S2	57	28	10-1800	1/2	2120	4031	4093	10-5/8	40	37	23	22	3-1/2	30-3/8	15	7-1/2	72	40#	6"

TB Trolley Speeds 45 & 60 fpm - 1/2 hp 1800 rpm
80 fpm - 1/2 hp 1200 rpm
90 & 120 fpm - 3/4 hp 1800 rpm

Additional lifts, speeds and non-rotating rope available, consult factory.
Yale reserves the right to make product changes as necessary.

2 Part Single Reeving - S2

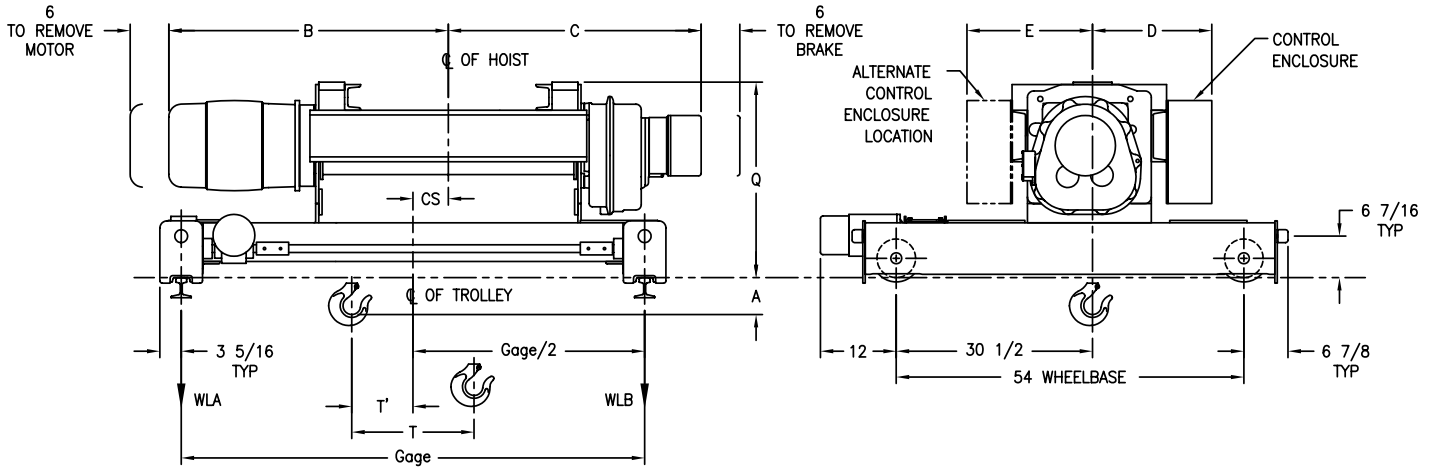

Drawing 23484203

Model Number	Lift (ft)	Speed fpm	Motor HP/RPM	Rope Dia.	Est Net Weight	WLA	WLB	A	B	C	D	E	CS	Q	T	T'	Gage Std.	Max Rail Size (ASCE)	Wheel Tread Dia.
CEW5X71TB16S2	71	16	7.5-1200	1/2	2170	4183	4292	10-5/8	43	41	23	22	5-1/2	30-3/8	19	9-1/2	72	40#	6"
CEW5X71TB19S2	71	19	7.5-1800	1/2	2170	4183	4292	10-5/8	43	41	23	22	5-1/2	30-3/8	19	9-1/2	72	40#	6"
CEW5X71TB28S2	71	28	10-1800	1/2	2170	4183	4292	10-5/8	44	40	23	22	5-1/2	30-3/8	19	9-1/2	72	40#	6"
DEW5-75TB30S2	75	30	10-1800	1/2	2370	4090	4191	12-7/8	39	37	26	25	4-1/2	31-1/8	15	7-1/2	72	40#	6"
DEW5-94TB30S2	94	30	15-1800	1/2	2480	4158	4292	12-7/8	43	41	26	25	6-1/2	31-1/8	19	9-1/2	84	40#	6"
EEW5-106TB25S2	106	25	10-1800	1/2	3280	4370	4576	10	42	44	26	25	6-1/2	35	19	9-1/2	84	40#	6"
EEW5-106TB50S2	106	50	20-1800	1/2	3280	4370	4576	10	45	44	27	26	6-1/2	35	19	9-1/2	84	40#	6"
DEW5-117TB30S2	117	30	15-1800	1/2	2620	4223	4389	12-7/8	47	45	26	25	8-1/2	31-1/8	23	11-1/2	96	40#	6"

TB Trolley Speeds
 45 & 60 fpm - 1/2 hp 1800 rpm
 80 fpm - 1/2 hp 1200 rpm
 90 & 120 fpm - 3/4 hp 1800 rpm

Additional lifts, speeds and non-rotating rope available, consult factory.
Yale reserves the right to make product changes as necessary.

2 Part Single Reeving - S2 4 Part Single Reeving - S4

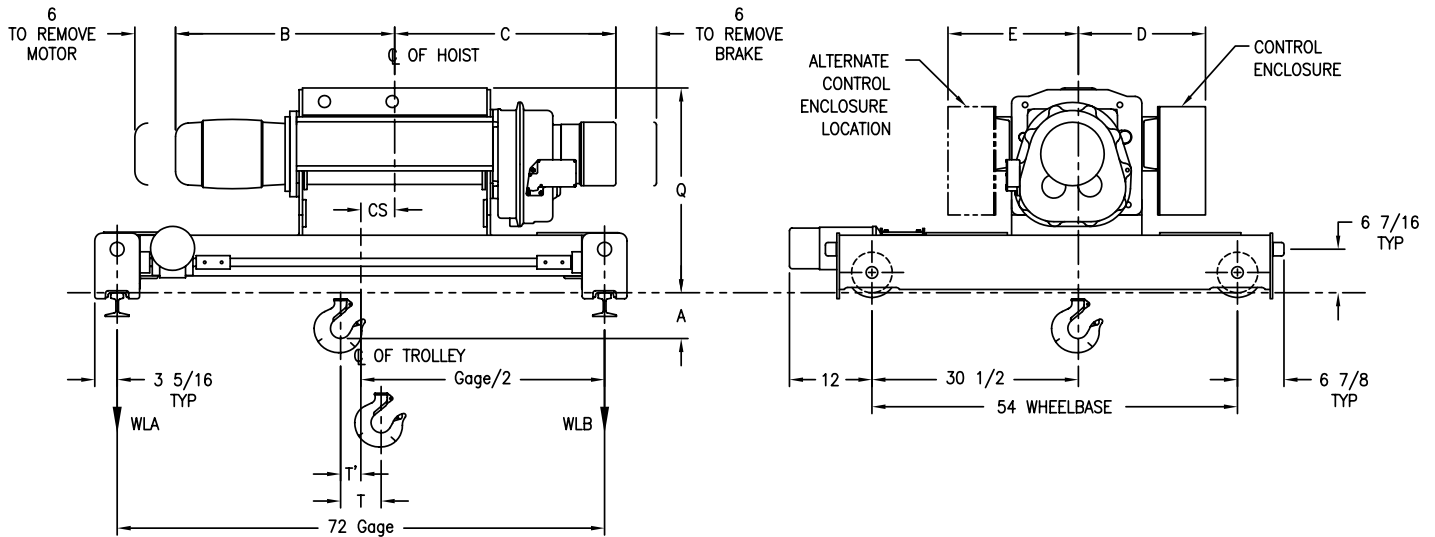

Drawing 23484204

Model Number	Lift (ft)	Speed fpm	Motor HP/RPM	Rope Dia.	Est Net Weight	WLA	WLB	A	B	C	D	E	CS	Q	T	T'	Max Rail Size (ASCE)	Wheel Tread Dia.
CEW7.5X18TB8S4	18	8	5-1200	7/16	2090	5149	5188	5-3/4	31	30	23	22	2-1/2	30-1/4	5	2-1/2	40#	6"
CEW7.5X18TB14S4	18	14	7.5-1800	7/16	2090	5149	5188	5-3/4	30	30	23	22	2-1/2	30-1/4	5	2-1/2	40#	6"
DEW7.5-24TB19S4	24	19	10-1800	7/16	2210	5124	5287	9-1/8	33	31	26	25	2-1/2	30-7/8	5	2-1/2	40#	6"
CEW7.5X26TB8S4	26	8	5-1200	7/16	2180	5207	5305	5-3/4	37	33	23	22	5	30-1/4	6	3	40#	6"
CEW7.5X26TB14S4	26	14	7.5-1800	7/16	2180	5207	5305	5-3/4	36	33	23	22	5	30-1/4	6	3	40#	6"
CEW7.5X33TB8S4	33	8	5-1200	7/16	2290	5320	5499	5-5/8	37	37	23	22	8	30-3/8	8	4	40#	6"
CEW7.5X33TB14S4	33	14	7.5-1800	7/16	2290	5320	5499	5-5/8	36	37	23	22	8	30-3/8	8	4	40#	6"
DEW7.5X33TB33S2	33	33	20-1800	5/8	2400	5432	5574	9-5/8	36	33	25	26	1/2	34-5/8	9	4-1/2	40#	6"
DEW7.5-34TB19S4	34	19	10-1800	7/16	2320	5242	5351	9-1/8	37	33	26	25	5	30-7/8	6	3	40#	6"
DEW7.5-37TB25S2	37	25	15-1800	5/8	2650	5562	5593	11-1/4	35	33	27	26	1-1/2	34-3/4	9	4-1/2	40#	6"

TB Trolley Speeds 45 & 60 fpm - 1/2 hp 1800 rpm
 80 fpm - 3/4 hp 1200 rpm
 90 & 120 fpm - 1 hp 1800 rpm

Additional lifts, speeds and non-rotating rope available, consult factory.
Yale reserves the right to make product changes as necessary.

2 Part Single Reeving - S2 4 Part Single Reeving - S4

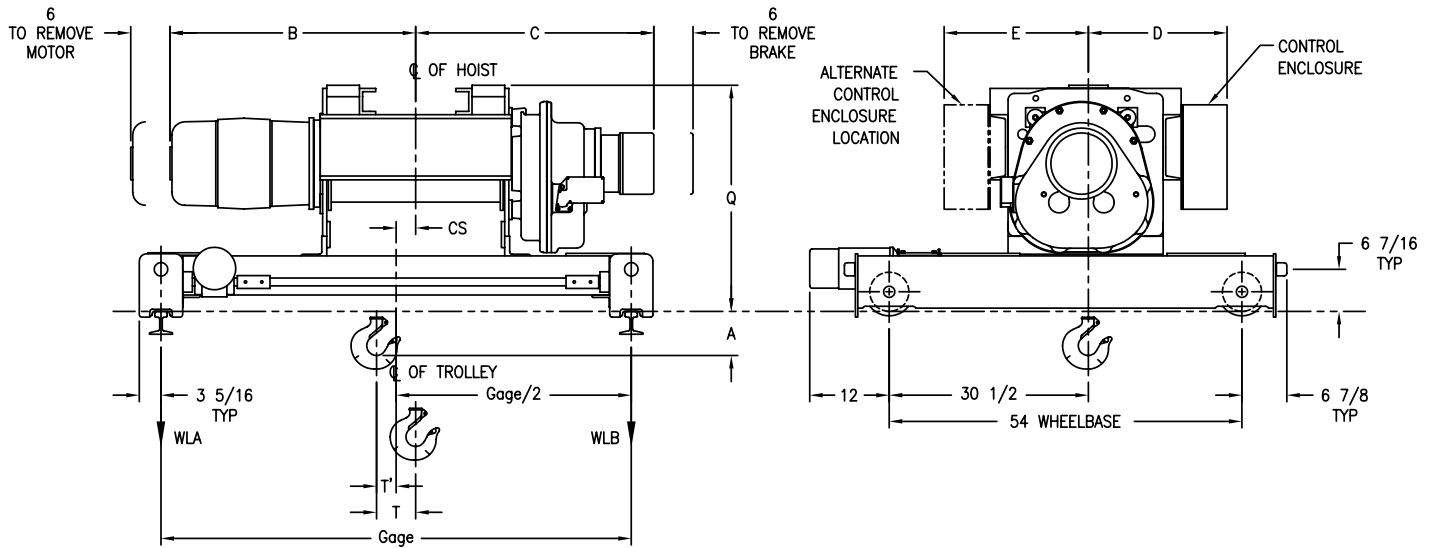

Drawing 23484205

Model Number	Lift (ft)	Speed fpm	Motor HP/RPM	Rope Dia.	Est Net Weight	WLA	WLB	A	B	C	D	E	CS	Q	T	T'	Gage Std.	Max Rail Size (ASCE)	Wheel Tread Dia.
CEW7.5X41TB14S4	41	14	7.5-1800	7/16	2300	5296	5494	9-5/8	40	34	23	22	10-1/2	30-3/8	9	4-1/2	84	40#	6"
DEW7.5-43TB19S4	43	19	10-1800	7/16	2420	5560	5332	8-7/8	39	37	26	25	5-1/2	31-1/8	8	5-1/2	72	40#	6"
DEW7.5X48TB33S2	48	33	20-1800	5/8	2590	5700	5773	10-3/8	39	38	26	25	3	34-5/8	12	6	72	40#	6"
DEW7.5-54TB19S4	54	19	10-1800	7/16	2540	5350	5582	8-7/8	43	41	26	25	10-1/2	31-1/8	9	4-1/2	84	40#	6"
EEW7.5-54TB25S2	54	25	15-1800	5/8	2850	5775	5861	11	38	38	27	26	3	35	12	6	72	40#	6"
DEW7.5X61TB33S2	61	33	20-1800	5/8	2660	5881	6002	10-3/8	42	41	26	25	4-1/2	34-5/8	15	7-1/2	72	40#	6"
EEW7.5-69TB25S2	69	25	15-1800	5/8	2950	5957	6100	11	41	41	27	26	4-1/2	35	15	7-1/2	72	40#	6"
DEW7.5X75TB33S2	75	33	20-1800	5/8	2780	5975	6135	10-3/8	45	44	26	25	6-1/2	34-5/8	19	9-1/2	84	40#	6"
EEW7.5-85TB2S2	85	25	15-1800	5/8	3090	6055	6242	11	44	44	27	26	6-1/2	35	19	9-1/2	84	40#	6"

TB Trolley Speeds
 45 & 60 fpm - 1/2 hp 1800 rpm
 80 fpm - 3/4 hp 1200 rpm
 90 & 120 fpm - 1 hp 1800 rpm

Additional lifts, speeds and non-rotating rope available, consult factory.

Yale reserves the right to make product changes as necessary.

4 Part Single Reeving - S4

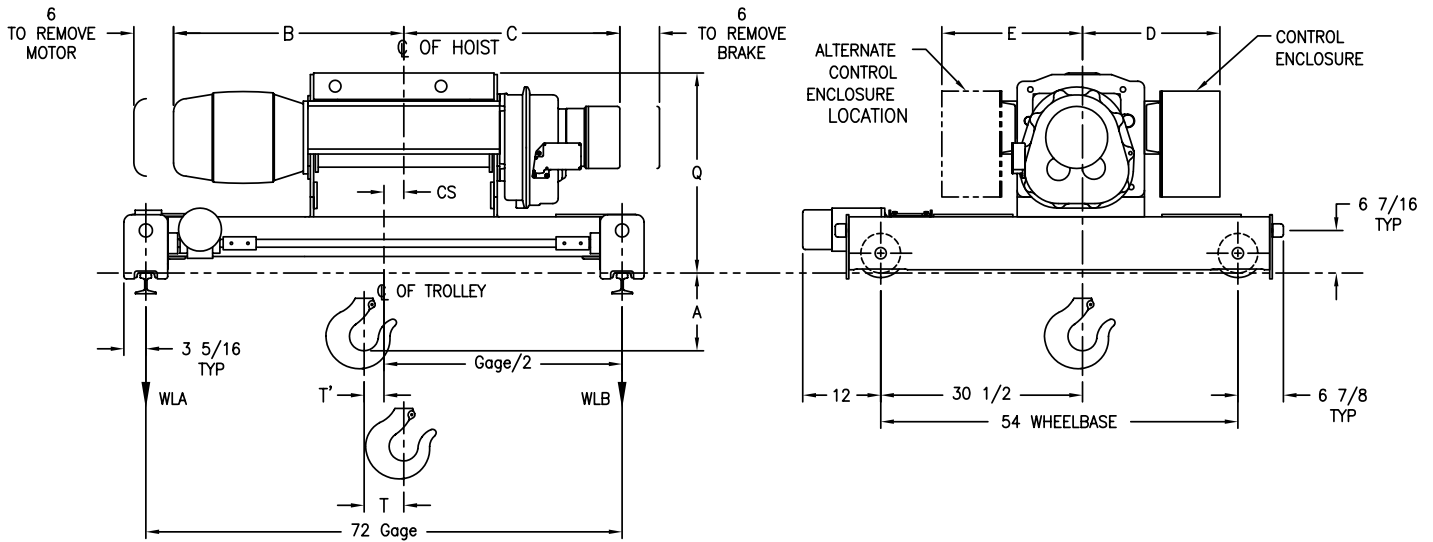

Drawing 23484206

Model Number	Lift (ft)	Speed fpm	Motor HP/RPM	Rope Dia.	Est Net Weight	WLA	WLB	A	B	C	D	E	CS	Q	T	T'	Max Rail Size (ASCE)	Wheel Tread Dia.
CEW10X16TB8S4	16	8	7.5-1200	1/2	2090	6681	6677	10-3/4	33	31	23	22	1/2	30-1/4	5	2-1/2	40#	6"
CEW10X16TB14S4	16	14	10-1800	1/2	2090	6681	6677	10-3/4	34	30	23	22	1/2	30-1/4	5	2-1/2	40#	6"
CEW10X22TB8S4	22	8	7.5-1200	1/2	2160	6755	6805	10-3/4	37	35	23	22	3	30-1/4	6	3	40#	6"
CEW10X22TB14S4	22	14	10-1800	1/2	2160	6755	6805	10-3/4	38	34	23	22	3	30-1/4	6	3	40#	6"
EEW10-23TB19S4	23	19	15-1800	1/2	3010	6921	6998	12-1/4	36	34	27	26	3/8	34-3/4	5	2-5/8	40#	6"
EEW10-23TB25S4	23	25	20-1800	1/2	3010	6921	6998	12-1/4	37	34	27	26	3/8	34-3/4	5	2-5/8	40#	6"
CEW10X28TB8S4	28	8	7.5-1200	1/2	2270	6910	7035	11-5/8	39	37	23	22	6	30-3/8	8	4	40#	6"
CEW10X28TB14S4	28	14	10-1800	1/2	2270	6910	7035	11-5/8	40	37	23	22	6	30-3/8	8	4	40#	6"
EEW10-34TB19S4	34	19	15-1800	1/2	3160	6977	7193	12-1/4	39	38	27	26	2-5/8	34-3/4	6	3-3/8	40#	6"
EEW10-34TB25S4	34	25	20-1800	1/2	3160	6977	7193	12-1/4	40	38	27	26	2-5/8	34-3/4	6	3-3/8	40#	6"

TB Trolley Speeds
 45 fpm - 1/2 hp 1800 rpm
 60 fpm - 3/4 hp 1800 rpm
 80 fpm - 1 hp 1200 rpm
 90 fpm - 1 hp 1800 rpm
 120 fpm - 1 1/2 hp 1800 rpm

Additional lifts, speeds and non-rotating rope available, consult factory.
Yale reserves the right to make product changes as necessary.

4 Part Single Reeving - S4

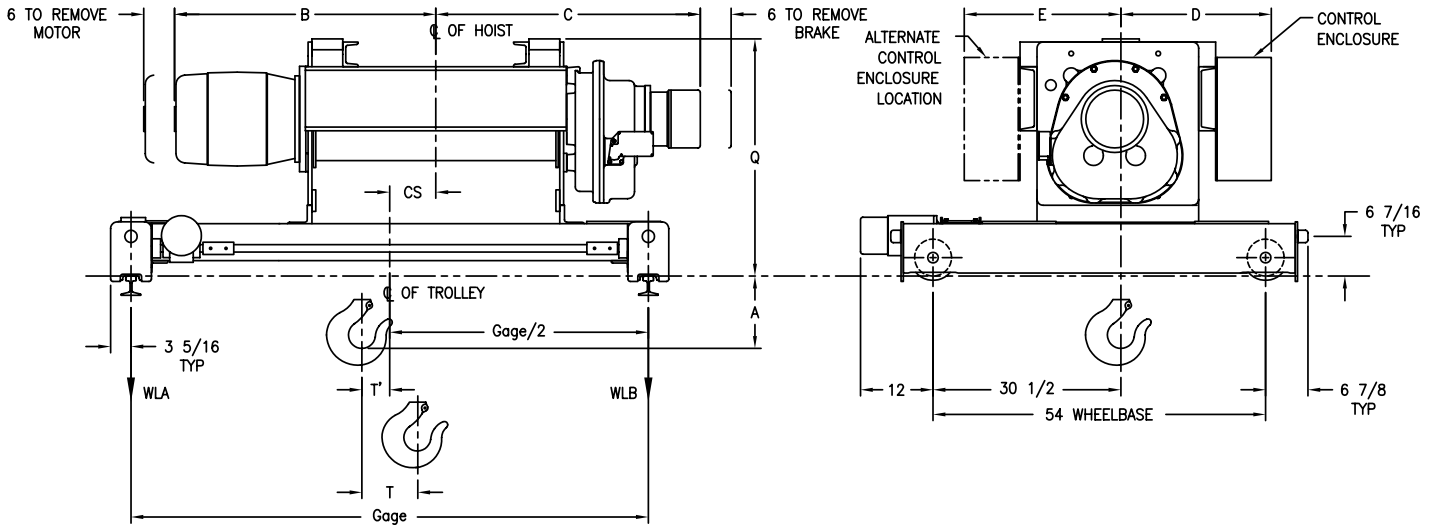

Drawing 23484207

Model Number	Lift (ft)	Speed fpm	Motor HP/RPM	Rope Dia.	Est Net Weight	WLA	WLB	A	B	C	D	E	CS	Q	T	T'	Gage Std.	Max Rail Size (ASCE)	Wheel Tread Dia.
CEW10X35TB8S4	35	8	7.5-1200	1/2	2350	7189	6764	11-5/8	43	41	23	22	6-1/2	34-3/4	9	6-1/2	84	40#	6"
CEW10X35TB14S4	35	14	10-1800	1/2	2350	7189	6764	11-5/8	44	40	23	22	6-1/2	34-3/4	9	6-1/2	84	40#	6"
EEW10-43TB19S4	43	19	15-1800	1/2	3290	7119	7272	12	41	41	27	26	5	35	8	4	84	40#	6"
EEW10-43TB25S4	43	25	20-1800	1/2	3290	7119	7272	12	42	41	27	26	5	35	8	4	84	40#	6"
EEW10-53TB19S4	53	19	15-1800	1/2	3380	7169	7414	12	44	44	27	26	7-1/2	35	9	4-1/2	84	40#	6"
EEW10-53TB25S4	53	25	20-1800	1/2	3380	7169	7414	12	45	44	27	26	7-1/2	35	9	4-1/2	84	40#	6"
DEW10-58TB15S4	58	15	10-1800	1/2	2880	7102	7374	11	47	45	24	25	12	34	12	6	96	40#	6"
EEW10-66TB19S4	66	19	15-1800	1/2	3570	7282	7621	12	49	49	27	26	11	35	12	6	96	40#	6"
EEW10-66TB25S4	66	25	20-1800	1/2	3570	7282	7621	12	50	49	27	26	11	35	12	6	96	40#	6"

TB Trolley Speeds
 45 fpm - 1/2 hp 1800 rpm
 60 fpm - 3/4 hp 1800 rpm
 80 fpm - 1 hp 1200 rpm
 90 fpm - 1 hp 1800 rpm
 120 fpm - 1 1/2 hp 1800 rpm

Additional lifts, speeds and non-rotating rope available, consult factory.
Yale reserves the right to make product changes as necessary.

2 Part Single Reeving - S2

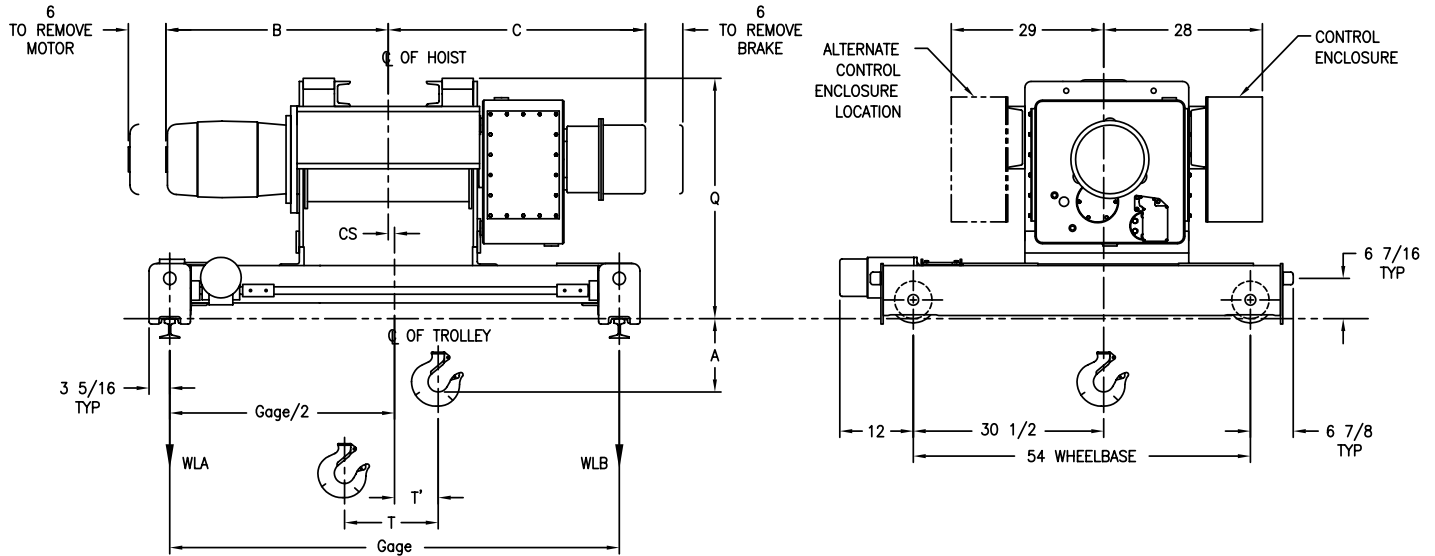

Drawing 23484208

Model Number	Lift (ft)	Speed fpm	Motor HP/RPM	Rope Dia.	Est Net Weight	WLA	WLB	A	B	C	CS	Q	T	T'	Gage Std.	Max Rail Size (ASCE)	Wheel Tread Dia.
EEW10X31TB26S2	31	26	20-1800	3/4	3700	7327	7653	20-3/4	36	40	1/2	38-1/4	9	3-1/2	72	40#	6"
EEW10X44TB26S2	44	26	20-1800	3/4	3910	7935	8129	20-1/2	39	43	1	38-1/2	12	4	72	40#	6"
EEW10X56TB26S2	56	26	20-1800	3/4	4030	7898	7904	20-1/2	42	46	1/2	38-1/2	15	7-1/2	84	40#	6"
EEW10X70TB26S2	70	26	20-1800	3/4	4130	8157	8253	20-1/2	45	49	2-1/2	38-1/2	19	9-1/2	84	40#	6"

TB Trolley Speeds
 45 fpm - 1/2 hp 1800 rpm
 60 fpm - 3/4 hp 1800 rpm
 80 fpm - 1 hp 1200 rpm
 90 fpm - 1 hp 1800 rpm
 120 fpm - 1 1/2 hp 1800 rpm

Additional lifts, speeds and non-rotating rope available, consult factory.
Yale reserves the right to make product changes as necessary.

4 Part Single Reeving - S4

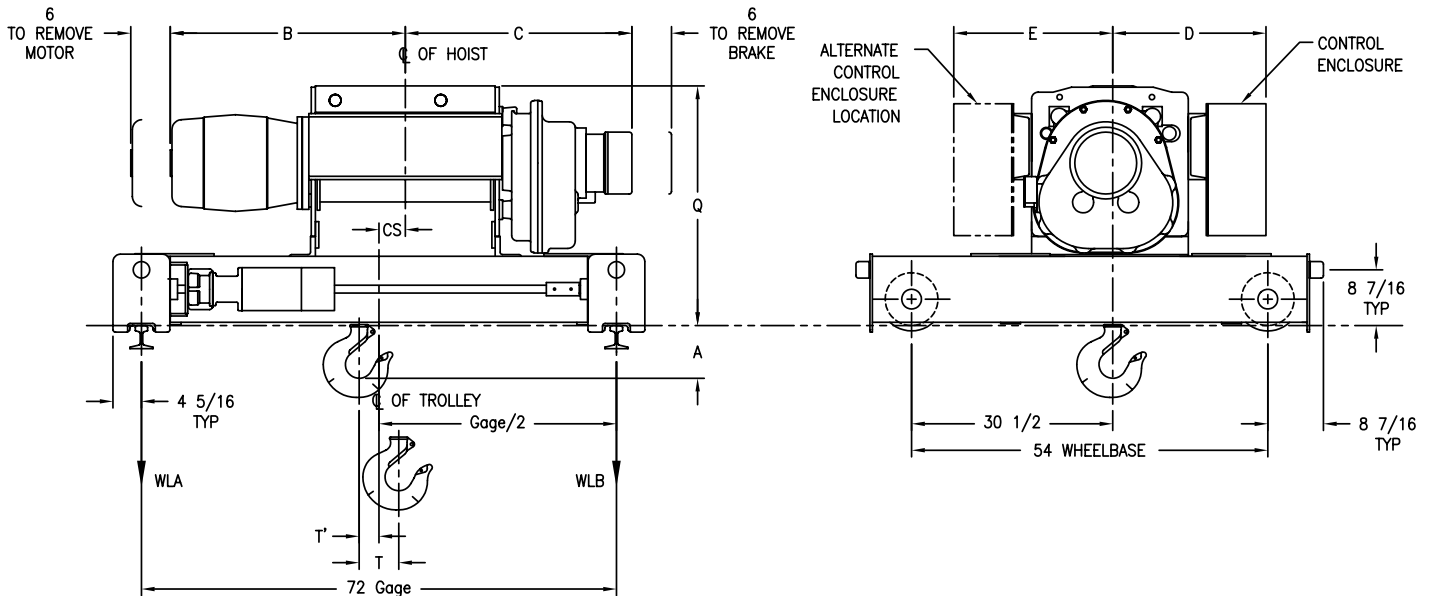

Drawing 23484209

Model Number	Lift (ft)	Speed fpm	Motor HP/RPM	Rope Dia.	Est Net Weight	WLA	WLB	A	B	C	D	E	CS	Q	T	T'	Max Rail Size (ASCE)	Wheel Tread Dia.
DEW15X16TB11S4	16	11	12-1800	5/8	3330	10080	10085	8-5/8	36	34	26	25	1/2	36-3/8	5	2-1/2	40#	8"
DEW15X16TB16S4	16	16	20-1800	5/8	3330	10080	10085	8-5/8	36	34	26	25	1/2	36-3/8	5	2-1/2	40#	8"
EEW15-18TB19S4	18	19	20-1800	5/8	3790	10811	9632	8-1/4	36	33	27	26	1/2	38-3/4	5	1-1/2	40#	8"
DEW15X24TB11S4	24	11	12-1800	5/8	3430	10175	10289	8-5/8	39	37	26	25	4	36-3/8	6	3	40#	8"
DEW15X24TB16S4	24	16	20-1800	5/8	3430	10175	10289	8-5/8	39	37	26	25	4	36-3/8	6	3	40#	8"
EEW15-27TB19S4	27	19	20-1800	5/8	3940	10976	9797	8-1/4	39	38	27	26	2	38-3/4	6	4	40#	8"

TB Trolley Speeds
 50 & 75 fpm - 1 hp 1800 rpm
 100 fpm - 1½ hp 1800 rpm
 125 fpm - 2 hp 1800 rpm

Additional lifts, speeds and non-rotating rope available, consult factory.
Yale reserves the right to make product changes as necessary.

4 Part Single Reeving - S4

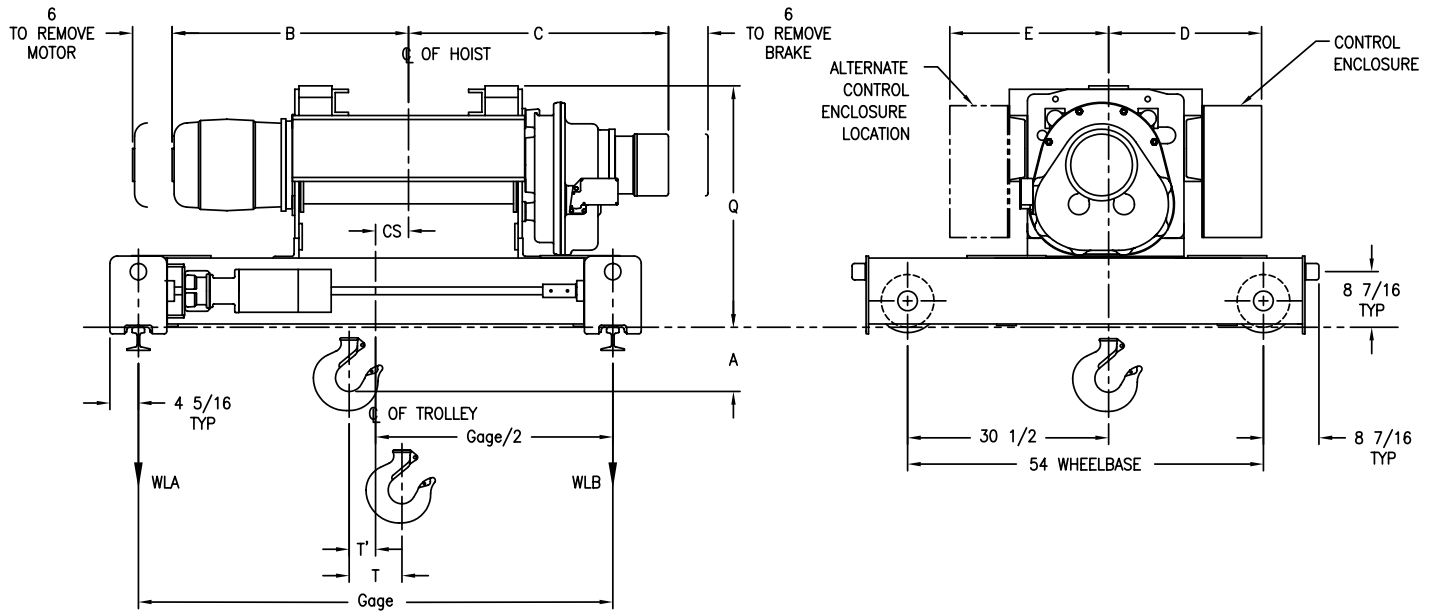

Drawing 23484210

Model Number	Lift (ft)	Speed fpm	Motor HP/RPM	Rope Dia.	Est Net Weight	WLA	WLB	A	B	C	D	E	CS	Q	T	T'	Gage Std.	Max Rail Size (ASCE)	Wheel Tread Dia.
DEW15X30TB11S4	30	11	12-1800	5/8	3520	10422	10573	8-3/8	42	41	26	25	5	36-5/8	8	4	72	40#	8"
DEW15X30TB16S4	30	16	20-1800	5/8	3520	10422	10573	8-3/8	42	41	26	25	5	36-5/8	8	4	72	40#	8"
EEW15-34TB19S4	34	19	20-1800	5/8	4050	10561	10755	10	42	41	27	26	5	39	8	4	72	40#	8"
DEW15X37TB11S4	37	11	12-1800	5/8	3670	10692	10322	8-3/8	45	44	26	25	7-1/8	36-5/8	9	5-7/8	84	40#	8"
DEW15X37TB16S4	37	16	20-1800	5/8	3670	10692	10322	8-3/8	45	44	26	25	7-1/8	36-5/8	9	5-7/8	84	40#	8"
EEW15-42TB19S4	42	19	20-1800	5/8	4230	10549	10809	10	45	44	27	26	7-1/2	39	9	4-1/2	84	40#	8"
DEW15X47TB11S4	47	11	12-1800	5/8	3870	10584	10858	8-3/8	50	49	26	25	11	36-5/8	12	6	96	40#	8"
DEW15X47TB16S4	47	16	20-1800	5/8	3870	10584	10858	8-3/8	50	49	26	25	11	36-5/8	12	6	96	40#	8"

TB Trolley Speeds 50 & 75 fpm - 1 hp 1800 rpm
100 fpm - 1½ hp 1800 rpm
125 fpm - 2 hp 1800 rpm

Additional lifts, speeds and non-rotating rope available, consult factory.
Yale reserves the right to make product changes as necessary.

4 Part Single Reeving - S4

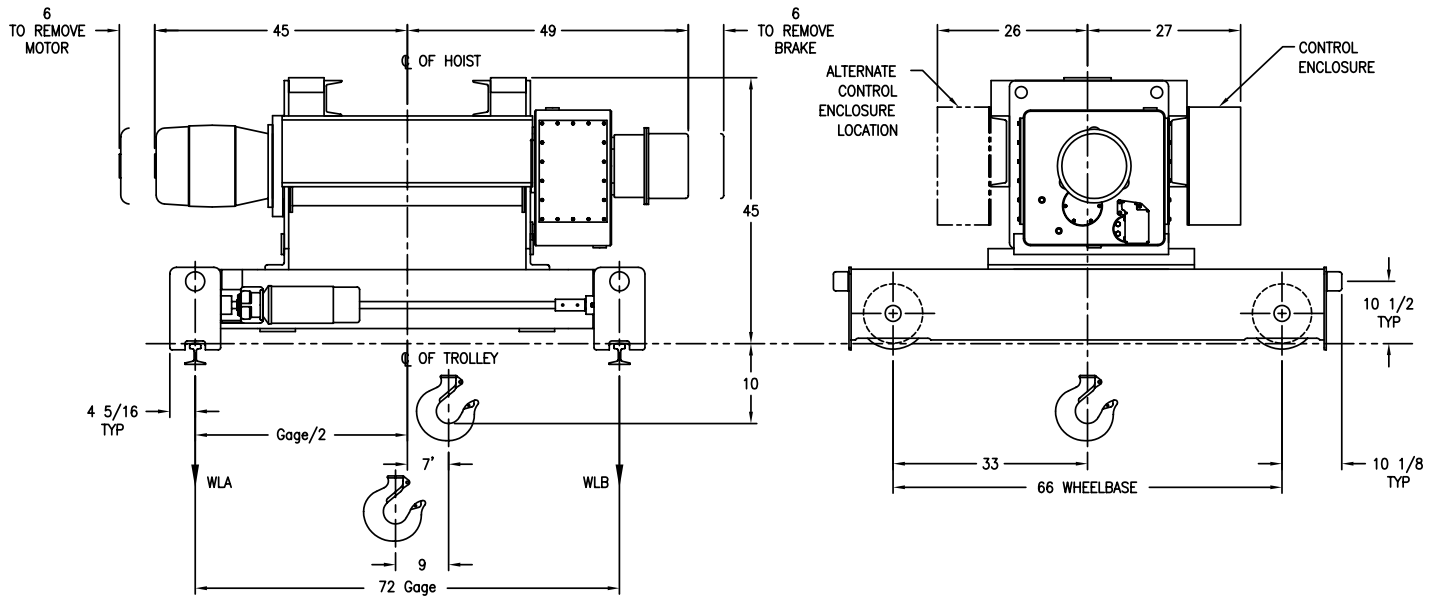

Drawing 23484211

Model Number	Lift (ft)	Speed fpm	Motor HP/RPM	Rope Dia.	Est Net Weight	WLA	WLB	Max Rail Size (ASCE)	Wheel Tread Dia.
EEW20X35TB9S4	35	9	15-1800	3/4	5200	12371	11064	40#	10"
EEW20X35TB13S4	35	13	20-1800	3/4	5390	12421	11113	40#	10"

TB Trolley Speeds

- 50 fpm - 1 hp 1800 rpm
- 75 fpm - 1½ hp 1800 rpm
- 100 fpm - 2 hp 1800 rpm
- 125 fpm - 3 hp 1800 rpm

Additional lifts, speeds and non-rotating rope available, consult factory.

Yale reserves the right to make product changes as necessary.

2 Part Double Reeving - D2 4 Part Double Reeving - D4

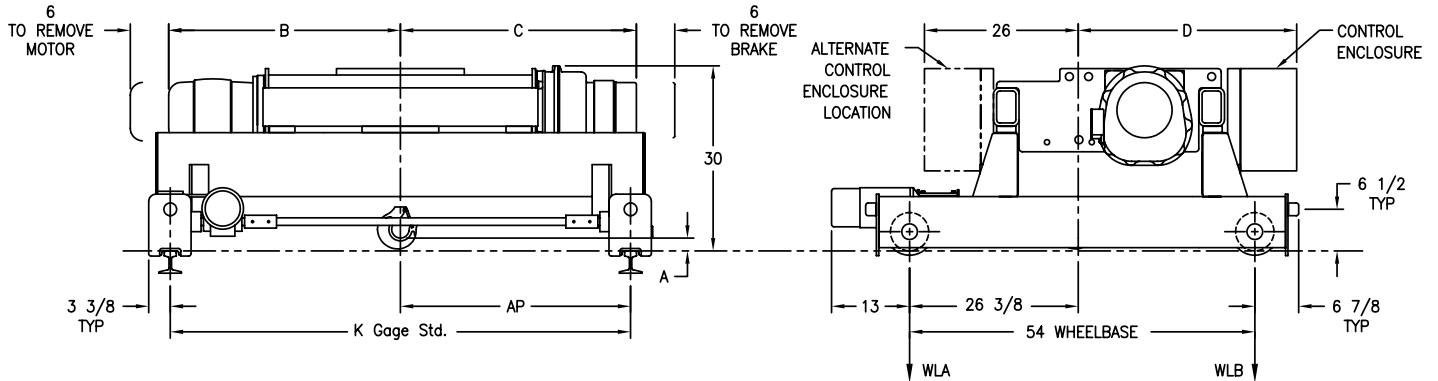

Drawing 23484301

Model Number	Lift (ft)	Speed fpm	Motor HP/RPM	Rope Dia.	Est Net Weight	WLA	WLB	A	B	C	D	K Gage Std.	AP (Gage/2)	Max Rail Size (ASCE)	Wheel Tread Dia.
CEW5X15TB19D2	15	19	7.5-1200	3/8	2840	3215	3205	5 1/2	35	30	36	48	24	40#	6"
CEW5X15TB28D2	15	28	10-1800	3/8	2870	3221	3214	5 1/2	35	30	36	48	24	40#	6"
BEW5X20TB12D4	20	12	5-1800	1/4	2460	3159	3069	1/2	36	35	33	60	30	40#	6"
BEW5X20TB15D4	20	15	5-1800	1/4	2460	3159	3069	1/2	36	35	33	60	30	40#	6"
CEW5X24TB19D2	24	19	7.5-1200	3/8	2860	3219	3211	5 1/2	38	34	36	48	24	40#	6"
CEW5X24TB28D2	24	28	10-1800	3/8	2900	3226	3224	5 1/2	38	34	36	48	24	40#	6"
BEW5X25TB12D4	25	12	5-1800	1/4	2560	3179	3098	1/2	39	39	33	72	36	40#	6"
BEW5X25TB15D4	25	15	5-1800	1/4	2560	3179	3098	1/2	39	39	33	72	36	40#	6"

TB Trolley Speeds 45 & 60 fpm - 1/2 hp 1800 rpm
80 fpm - 1/2 hp 1200 rpm
90 & 120 fpm - 3/4 hp 1800 rpm

Additional lifts, speeds and non-rotating rope available, consult factory.

Yale reserves the right to make product changes as necessary.

2 Part Double Reeving - D2
4 Part Double Reeving - D4

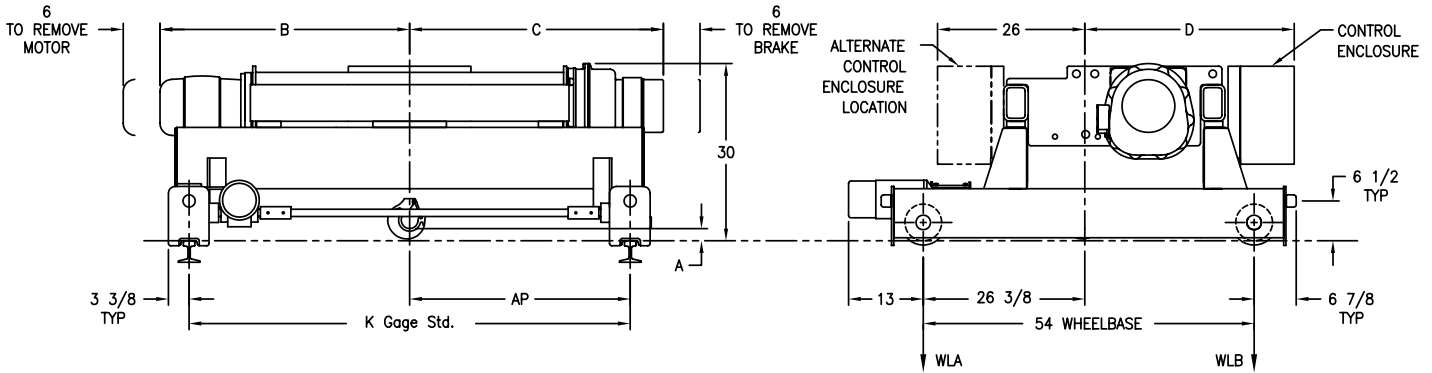

Drawing 23484302

Model Number	Lift (ft)	Speed fpm	Motor HP/RPM	Rope Dia.	Est Net Weight	WLA	WLB	A	B	C	D	K Gage Std.	AP (Gage/2)	Max Rail Size (ASCE)	Wheel Tread Dia.
CEW5X32TB19D2	32	19	7.5-1200	3/8	2940	3234	3234	5-1/2	41	37	36	60	30	40#	6"
CEW5X32TB28D2	32	28	10-1800	3/8	2980	3242	3247	5-1/2	41	37	36	60	30	40#	6"
BEW5X33TB12D4	33	12	5-1800	1/4	2620	3190	3117	1/2	44	44	33	72	36	40#	6"
BEW5X33TB15D4	33	15	5-1800	1/4	2620	3190	3117	1/2	44	44	33	72	36	40#	6"
CEW5X41TB19D2	41	19	7.5-1200	3/8	3000	3245	3253	5-1/2	45	40	36	60	30	40#	6"
CEW5X41TB28D2	41	28	10-1800	3/8	3030	3250	3263	5-1/2	45	40	36	60	30	40#	6"
CEW5X54TB19D2	54	19	7.5-1200	3/8	3100	3266	3284	5-1/2	49	45	36	72	36	40#	6"
CEW5X54TB28D2	54	28	10-1800	3/8	3140	3273	3297	5-1/2	49	45	36	72	36	40#	6"

TB Trolley Speeds 45 & 60 fpm - 1/2 hp 1800 rpm
80 fpm - 1/2 hp 1200 rpm
90 & 120 fpm - 3/4 hp 1800 rpm

Additional lifts, speeds and non-rotating rope available, consult factory.
Yale reserves the right to make product changes as necessary.

2 Part Double Reeving

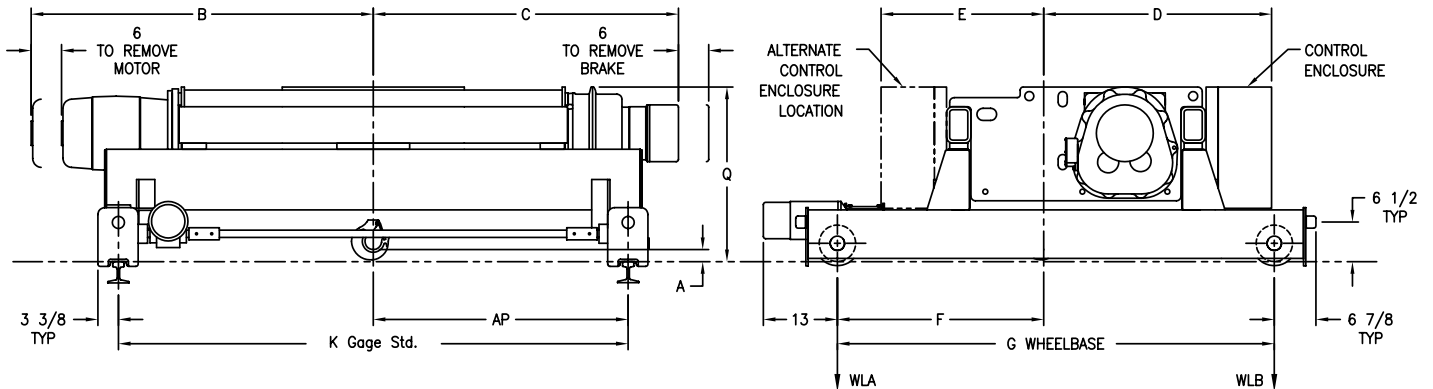

Drawing 23484303

Model Number	Lift (ft)	Speed fpm	Motor HP/RPM	Rope Dia.	Est Net Weight	WLA	WLB	A	B	C	D	E	F	G	K Gage Std.	AP (Gage/2)	Q	Max Rail Size (ASCE)	Wheel Tread Dia.
DEW5-71TB20D2	71	20	7.5-1200	3/8	3330	3313	3352	6-1/2	47	45	39	28	26-3/8	54	72	36	30	40#	6"
DEW5-71TB30D2	71	30	15-1800	3/8	3180	3287	3303	6-1/2	47	45	39	28	26-3/8	54	72	36	30	40#	6"
DEW5-94TB30D2	94	30	15-1800	3/8	3520	3505	3254	6-1/2	54	52	39	28	34	72	84	42	30	40#	6"
EEW5-105TB25D2	105	25	10-1800	3/8	4660	3687	3641	9-1/2	54	55	45	31	34	72	84	42	34	40#	6"
EEW5-105TB50D2	105	50	20-1800	3/8	4960	3743	3735	9-1/2	57	55	45	31	34	72	84	42	34	40#	6"
EEW5-147TB25D2	147	25	10-1800	3/8	5200	3794	3803	9-1/2	65	66	45	31	34	72	108	54	34	40#	6"
EEW5-147TB50D2	147	50	20-1800	3/8	5500	3850	3897	9-1/2	68	66	45	31	34	72	108	54	34	40#	6"

TB Trolley Speeds 45 & 60 fpm - 1/2 hp 1800 rpm
80 fpm - 1/2 hp 1200 rpm
90 & 120 fpm - 3/4 hp 1800 rpm

Additional lifts, speeds and non-rotating rope available, consult factory.

Yale reserves the right to make product changes as necessary.

2 Part Double Reeving - D2 4 Part Double Reeving - D4

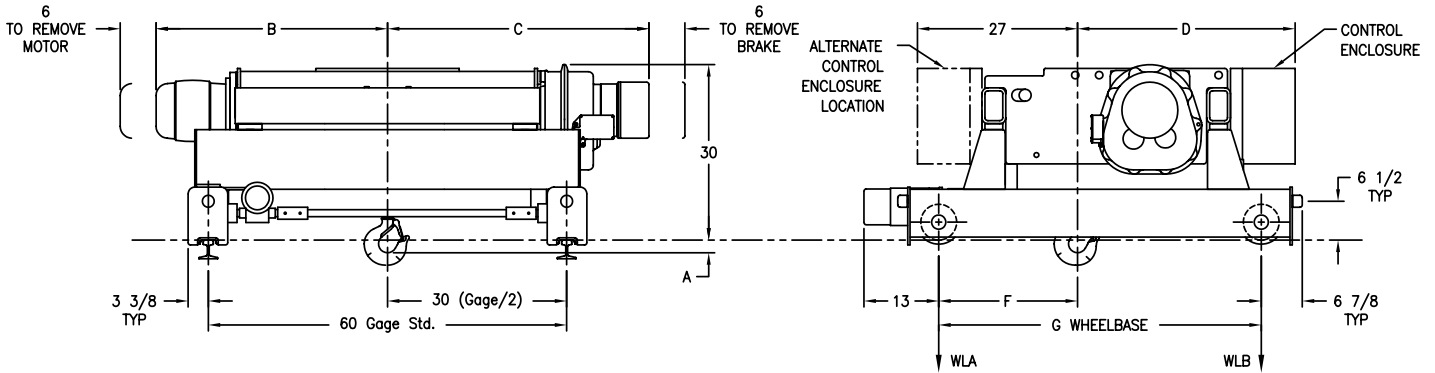

Drawing 23484304

Model Number	Lift (ft)	Speed fpm	Motor HP/RPM	Rope Dia.	Est Net Weight	WLA	WLB	A	B	C	D	F	G	Max Rail Size (ASCE)	Wheel Tread Dia.
CEW7.5X19TB8D4	19	8	5-1200	5/16	3100	5064	3985	1-1/2	37	37	35	23-1/4	54	40#	6"
CEW7.5X19TB14D4	19	14	7.5-1800	5/16	2870	5016	3918	1-1/2	41	37	35	23-1/4	54	40#	6"
DEW7.5-19TB19D4	19	19	10-1800	5/16	3030	5037	3977	2-1/2	36	34	38	23-1/4	54	40#	6"
CEW7.5X25TB8D4	25	8	5-1200	5/16	3170	5078	4005	1-1/2	40	40	35	23-1/4	54	40#	6"
CEW7.5X25TB14D4	25	14	7.5-1800	5/16	2940	5030	3938	1-1/2	45	40	35	23-1/4	54	40#	6"
DEW7.5-25TB19D4	25	19	10-1800	5/16	3110	5053	4001	2-1/2	39	37	38	23-1/4	54	40#	6"
DEW7.5X28TB33D2	28	33	20-1800	7/16	3480	4917	4318	1-1/2*	39	38	38	33	72	40#	6"

TB Trolley Speeds 45 & 60 fpm - 1/2 hp 1800 rpm
80 fpm - 3/4 hp 1200 rpm
90 & 120 fpm - 1 hp 1800 rpm

Additional lifts, speeds and non-rotating rope available, consult factory.
Yale reserves the right to make product changes as necessary.

*Distance above rail to hook saddle

2 Part Double Reeving - D2 4 Part Double Reeving - D4

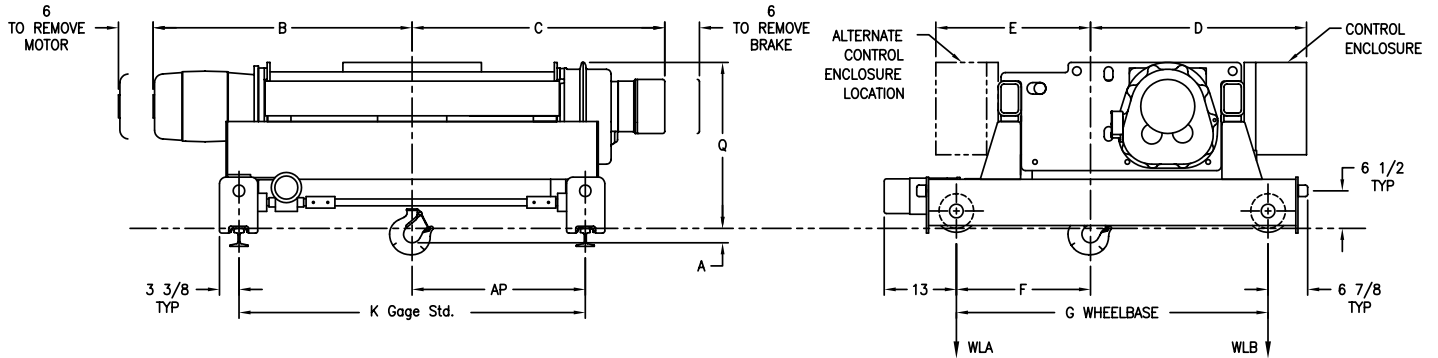

Drawing 23484305

Model Number	Lift (ft)	Speed fpm	Motor HP/RPM	Rope Dia.	Est Net Weight	WLA	WLB	A	B	C	D	E	F	G	K Gage Std.	AP (Gage/2)	Q	Max Rail Size (ASCE)	Wheel Tread Dia.
CEW7.5X32TB8D4	32	8	5-1200	5/16	3510	5017	4236	1/2*	45	45	35	27	32-1/2	72	72	36	30	40#	6"
CEW7.5X32TB14D4	32	14	7.5-1800	5/16	3290	4969	4173	1/2*	49	45	35	27	32-1/2	72	72	36	30	40#	6"
DEW7.5-32TB19D4	32	19	10-1800	5/16	3190	5069	4024	2-1/2	43	41	38	27	23-1/4	54	60	30	30	40#	6"
EEW7.5-32TB25D2	32	25	15-1800	7/16	3740	4944	4421	4-1/2*	38	38	43	30	33	72	60	30	32	40#	6"
DEW7.5X37TB33D2	37	33	20-1800	7/16	3550	4931	4339	1-1/2*	42	41	38	27	33	72	60	30	31	40#	6"
DEW7.5-42TB19D4	42	19	10-1800	5/16	3310	5051	4102	2-1/2	47	45	38	27	23-1/4	54	60	30	30	40#	6"
EEW7.5-43TB25D2	43	25	15-1800	7/16	3850	4966	4455	4-1/2*	41	41	43	30	33	72	60	30	32	40#	6"
DEW7.5X47TB33D2	47	33	20-1800	7/16	3640	4950	4366	1-1/2*	45	44	38	27	33	72	60	30	31	40#	6"

TB Trolley Speeds 45 & 60 fpm - 1/2 hp 1800 rpm
80 fpm - 3/4 hp 1200 rpm
90 & 120 fpm - 1 hp 1800 rpm

Additional lifts, speeds and non-rotating rope available, consult factory.

Yale reserves the right to make product changes as necessary.

*Distance above rail to hook saddle

2 Part Double Reeving - D2 4 Part Double Reeving - D4

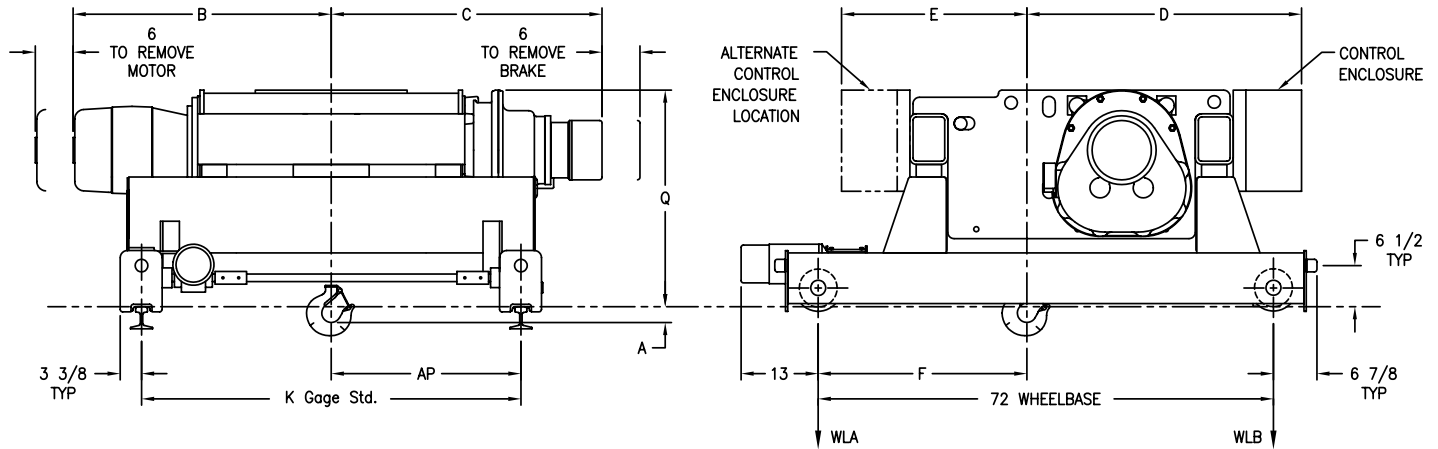

Drawing 23484306

Model Number	Lift (ft)	Speed fpm	Motor HP/RPM	Rope Dia.	Est Net Weight	WLA	WLB	A	B	C	D	E	F	K Gage Std.	AP (Gage/2)	Q	Max Rail Size (ASCE)	Wheel Tread Dia.
DEW7.5-55TB19D4	55	19	10-1800	5/16	3610	5023	4281	2-1/2	54	52	38	27	32-1/2	72	36	30	40#	6"
EEW7.5-55TB25D2	55	25	15-1800	7/16	3980	4991	4494	4-1/2*	44	44	43	30	33	60	30	32	40#	6"
DEW7.5X61TB33D2	61	33	20-1800	7/16	3820	4990	4417	1-1/2*	50	49	38	27	33	72	36	31	40#	6"
EEW7.5-71TB25D2	71	25	15-1800	7/16	4230	5044	4569	4-1/2*	49	49	43	30	33	72	36	32	40#	6"
DEW7.5X80TB33D2	80	33	20-1800	7/16	4050	5093	4431	1-1/2*	56	55	38	27	32-1/2	84	42	31	40#	6"
EEW7.5-91TB25D2	91	25	15-1800	7/16	4510	5103	4652	4-1/2*	55	55	43	30	33	84	42	32	40#	6"
EEW7.5-128TB38D2	128	38	20-1800	7/16	5480	4818	5420	4-1/2*	67	65	43	30	37-5/8	108	54	32	40#	6"

TB Trolley Speeds 45 & 60 fpm - 1/2 hp 1800 rpm
80 fpm - 3/4 hp 1200 rpm
90 & 120 fpm - 1 hp 1800 rpm

Additional lifts, speeds and non-rotating rope available, consult factory.
Yale reserves the right to make product changes as necessary.

*Distance above rail to hook saddle

2 Part Double Reeving

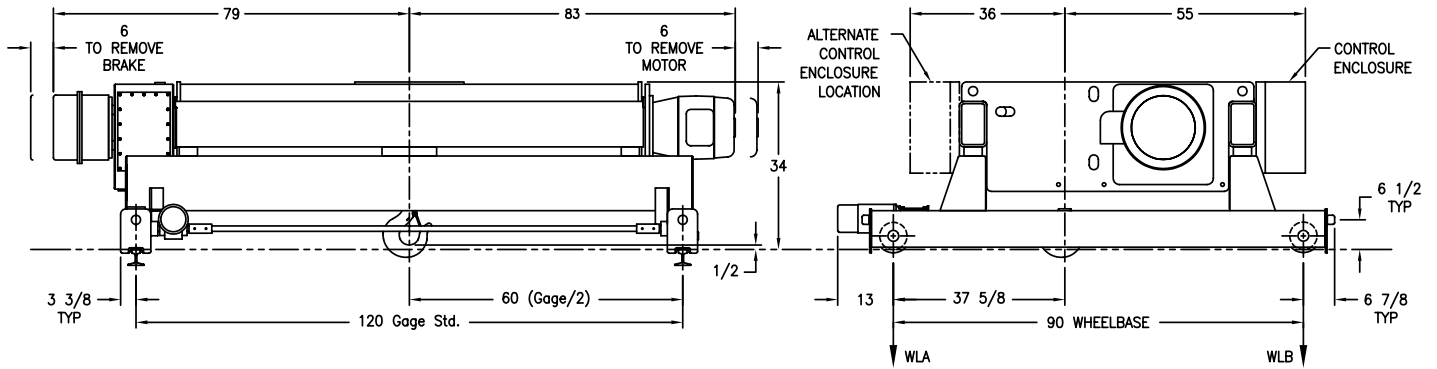

Drawing 23484307

Model Number	Lift (ft)	Speed fpm	Motor HP/RPM	Rope Dia.	Est Net Weight	WLA	WLB	Max Rail Size (ASCE)	Wheel Tread Dia.
FEW7.5-173TB35D2	173	35	20-1800	7/16	7390	6085	5109	40#	6"

TB Trolley Speeds 45 & 60 fpm - 1/2 hp 1800 rpm
 80 fpm - 3/4 hp 1200 rpm
 90 & 120 fpm - 1 hp 1800 rpm

Additional lifts, speeds and non-rotating rope available, consult factory.
Yale reserves the right to make product changes as necessary.

4 Part Double Reeving

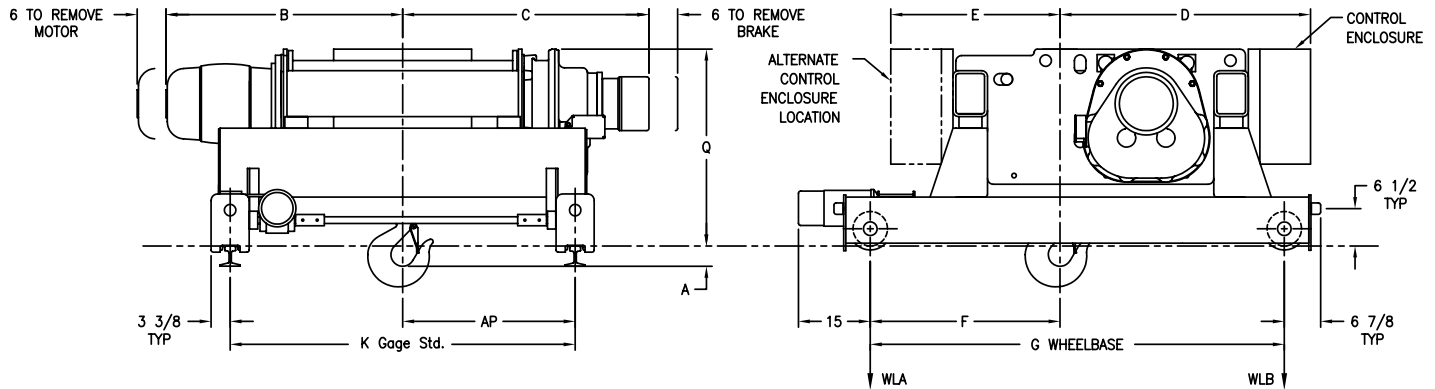

Drawing 23484308

Model Number	Lift (ft)	Speed fpm	Motor HP/RPM	Rope Dia.	Est Net Weight	WLA	WLB	A	B	C	D	E	F	G	K Gage Std.	AP (Gage/2)	Q	Max Rail Size (ASCE)	Wheel Tread Dia.
CEW10X20TB8D4	20	8	7.5-1200	3/8	3250	5282	6343	5-1/2	45	40	37	27	29-1/8	54	60	30	30	40#	6"
CEW10X20TB14D4	20	14	10-1800	3/8	3060	5252	6277	5-1/2	45	40	37	27	29-1/8	54	60	30	30	40#	6"
EEW10-23TB19D4	23	19	15-1800	3/8	4160	6380	5695	3-1/2	41	41	44	30	33	72	60	30	35	40#	6"
EEW10-23TB25D4	23	25	20-1800	3/8	4530	6452	5808	3-1/2	43	41	44	30	33	72	60	30	35	40#	6"
CEW10X25TB8D4	25	8	7.5-1200	3/8	3360	5300	6376	5-1/2	49	45	37	27	29-1/8	54	72	36	30	40#	6"
CEW10X25TB14D4	25	14	10-1800	3/8	3220	5279	6327	5-1/2	49	45	37	27	29-1/8	54	72	36	30	40#	6"
EEW10-30TB19D4	30	19	15-1800	3/8	4300	6407	5738	3-1/2	44	44	44	30	33	72	60	30	35	40#	6"
EEW10-30TB25D4	30	25	20-1800	3/8	4680	6481	5854	3-1/2	46	44	44	30	33	72	60	30	35	40#	6"

TB Trolley Speeds
 45 fpm - 1/2 hp 1800 rpm
 60 fpm - 3/4 hp 1800 rpm
 80 fpm - 1 hp 1200 rpm
 90 fpm - 1 hp 1800 rpm
 120 fpm - 1 1/2 hp 1800 rpm

Additional lifts, speeds and non-rotating rope available, consult factory.

Yale reserves the right to make product changes as necessary.

4 Part Double Reeving

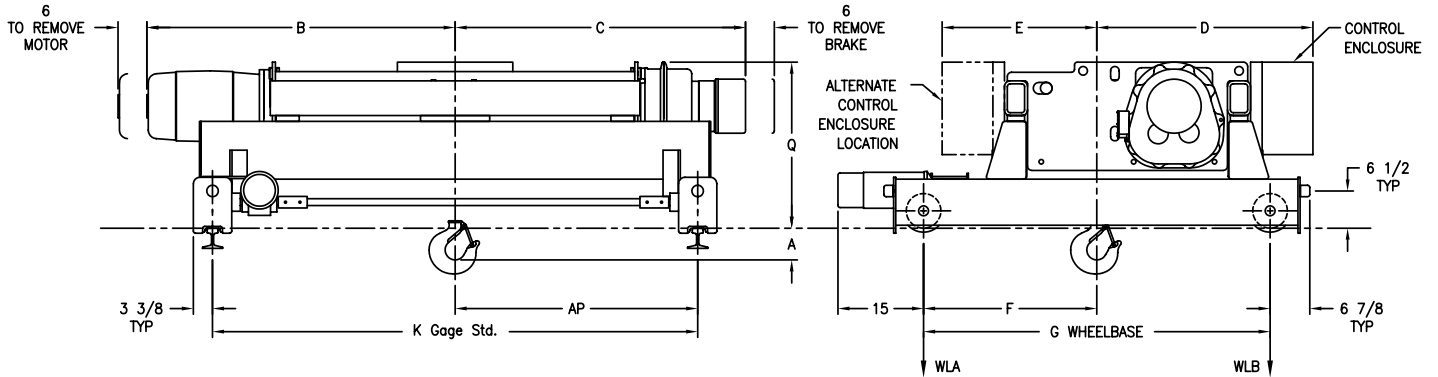

Drawing 23484309

Model Number	Lift (ft)	Speed fpm	Motor HP/RPM	Rope Dia.	Est Net Weight	WLA	WLB	A	B	C	D	E	F	G	K Gage Std.	AP (Gage/2)	Q	Max Rail Size (ASCE)	Wheel Tread Dia.
DEW10-35TB15D4	35	15	10-1800	3/8	3480	5776	5960	5-1/2	47	45	38	27	30	60	72	36	30	40#	6"
EEW10-38TB19D4	38	19	15-1800	3/8	4580	6466	5821	3-1/2	49	49	44	30	33	72	72	36	35	40#	6"
EEW10-38TB25D4	38	25	20-1800	3/8	4940	6536	5931	3-1/2	51	49	44	30	33	72	72	36	35	40#	6"
DEW10-46TB15D4	46	15	10-1800	3/8	3700	5776	6074	5-1/2	54	52	38	27	30	60	84	42	30	40#	6"
EEW10-50TB19D4	50	19	15-1800	3/8	4890	6531	5914	3-1/2	55	55	44	30	33	72	84	42	35	40#	6"
EEW10-50TB25D4	50	25	20-1800	3/8	5240	6599	6021	3-1/2	57	55	44	30	33	72	84	42	35	40#	6"
EEW10-71TB19D4	71	19	15-1800	3/8	5480	6654	6084	3-1/2	68	66	44	30	33	72	108	54	35	40#	6"
EEW10-71TB25D4	71	25	20-1800	3/8	5830	6722	6191	3-1/2	68	66	44	30	33	72	108	54	35	40#	6"

TB Trolley Speeds
 45 fpm - 1/2 hp 1800 rpm
 60 fpm - 3/4 hp 1800 rpm
 80 fpm - 1 hp 1200 rpm
 90 fpm - 1 hp 1800 rpm
 120 fpm - 1 1/2 hp 1800 rpm

Additional lifts, speeds and non-rotating rope available, consult factory.
Yale reserves the right to make product changes as necessary.

2 Part Double Reeving

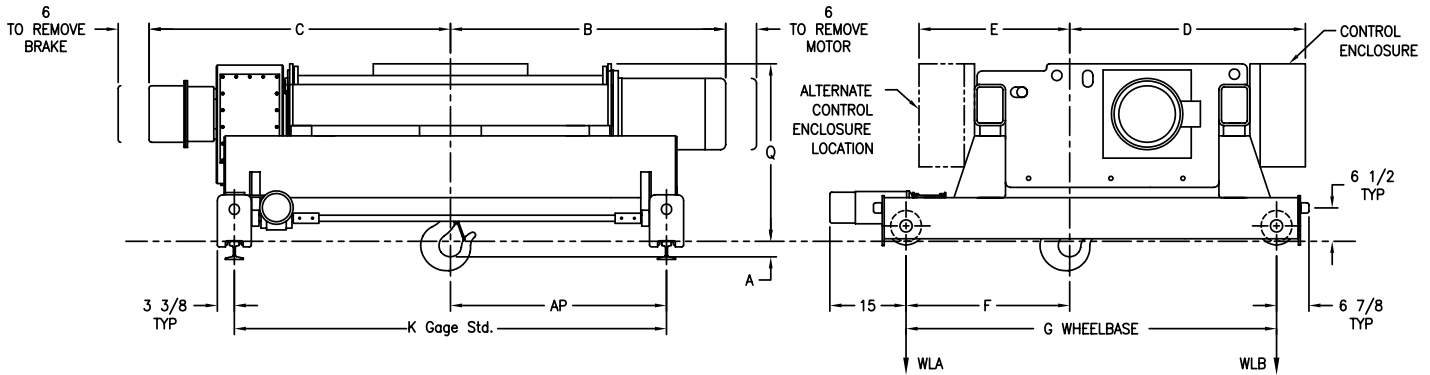

Drawing 23484310

Model Number	Lift (ft)	Speed fpm	Motor HP/RPM	Rope Dia.	Est Net Weight	WLA	WLB	A	B	C	D	E	F	G	K Gage Std.	AP (Gage/2)	Q	Max Rail Size (ASCE)	Wheel Tread Dia.
EEW10X33TB26D2	33	26	20-1800	1/2	4750	6646	5725	1/2	43	46	46	30	31-7/8	72	60	30	35	40#	6"
EEW10X44TB26D2	44	26	20-1800	1/2	4880	6671	5765	1/2	46	49	46	30	31-7/8	72	60	30	35	40#	6"
EEW10X57TB26D2	57	26	20-1800	1/2	4110	6527	5526	1/2	51	54	46	30	31-7/8	72	72	36	35	40#	6"
EEW10X75TB26D2	75	26	20-1800	1/2	5450	6789	5935	1/2	57	60	46	30	31-7/8	72	84	42	35	40#	6"
EEW10X106TB19D2	106	19	15-1800	1/2	5930	6890	6072	1/2	67	70	46	30	31-7/8	72	108	54	35	40#	6"
EEW10X106TB26D2	106	26	20-1800	1/2	5950	6894	6078	1/2	67	70	46	30	31-7/8	72	108	54	35	40#	6"
FEW10-150TB21D2	150	21	15-1800	1/2	7350	7532	6143	7-1/2	79	79	52	34	37-5/8	90	120	60	37	40#	6"
FEW10-150TB29D2	150	29	20-1800	1/2	7350	7532	6143	7-1/2	79	79	52	34	37-5/8	90	120	60	37	40#	6"
FEW10-150TB46D2	150	46	30-1800	1/2	7790	7637	6253	7-1/2	95	79	52	34	37-5/8	90	144	72	37	40#	6"

TB Trolley Speeds
 45 fpm - 1/2 hp 1800 rpm
 60 fpm - 3/4 hp 1800 rpm
 80 fpm - 1 hp 1200 rpm
 90 fpm - 1 hp 1800 rpm
 120 fpm - 1 1/2 hp 1800 rpm

Additional lifts, speeds and non-rotating rope available, consult factory.

Yale reserves the right to make product changes as necessary.

4 Part Double Reeving

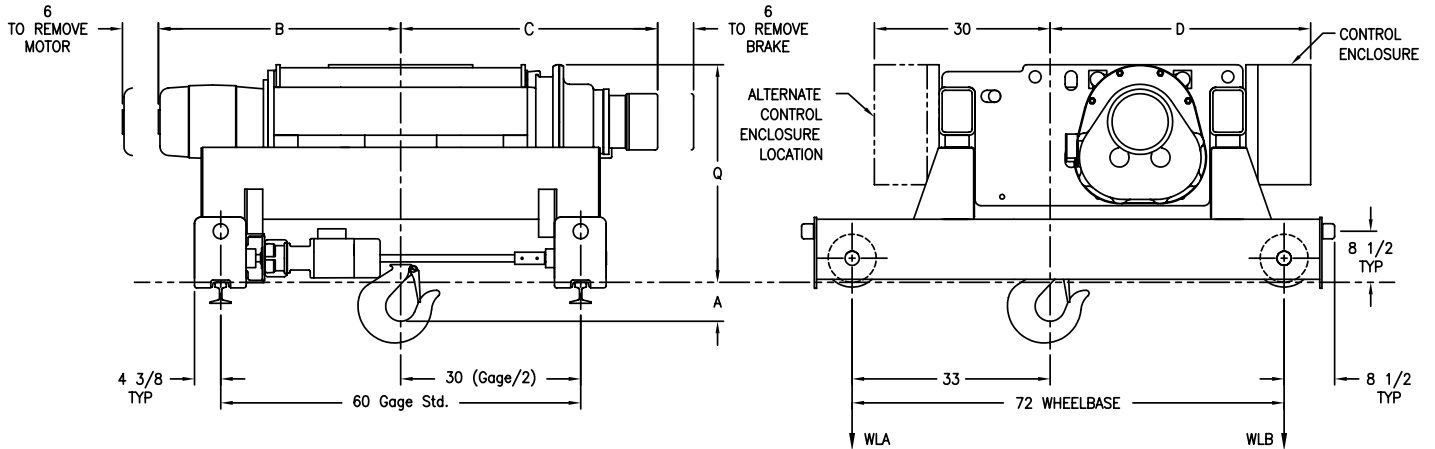

Drawing 23484311

Model Number	Lift (ft)	Speed fpm	Motor HP/RPM	Rope Dia.	Est Net Weight	WLA	WLB	A	B	C	D	Q	Max Rail Size (ASCE)	Wheel Tread Dia.
DEW15X17TB11D4	17	11	12-1800	7/16	4290	9146	7998	4-1/2	41	41	43	39	40#	8"
DEW15X17TB16D4	17	16	20-1800	7/16	4290	9146	7998	6-1/2	42	41	43	39	40#	8"
EEW15-19TB19D4	19	19	20-1800	7/16	4860	9247	8182	6-1/2	42	41	44	37	40#	8"
DEW15X22TB11D4	22	11	12-1800	7/16	4390	9166	8028	4-1/2	44	44	43	39	40#	8"
DEW15X22TB16D4	22	16	20-1800	7/16	4390	9166	8028	6-1/2	45	44	43	39	40#	8"
EEW15-25TB19D4	25	19	20-1800	7/16	5000	9274	8225	6-1/2	45	44	44	37	40#	8"

TB Trolley Speeds 50 & 75 fpm - 1 hp 1800 rpm
 100 fpm - 1½ hp 1800 rpm
 125 fpm - 2 hp 1800 rpm

Additional lifts, speeds and non-rotating rope available, consult factory.

Yale reserves the right to make product changes as necessary.

4 Part Double Reeving

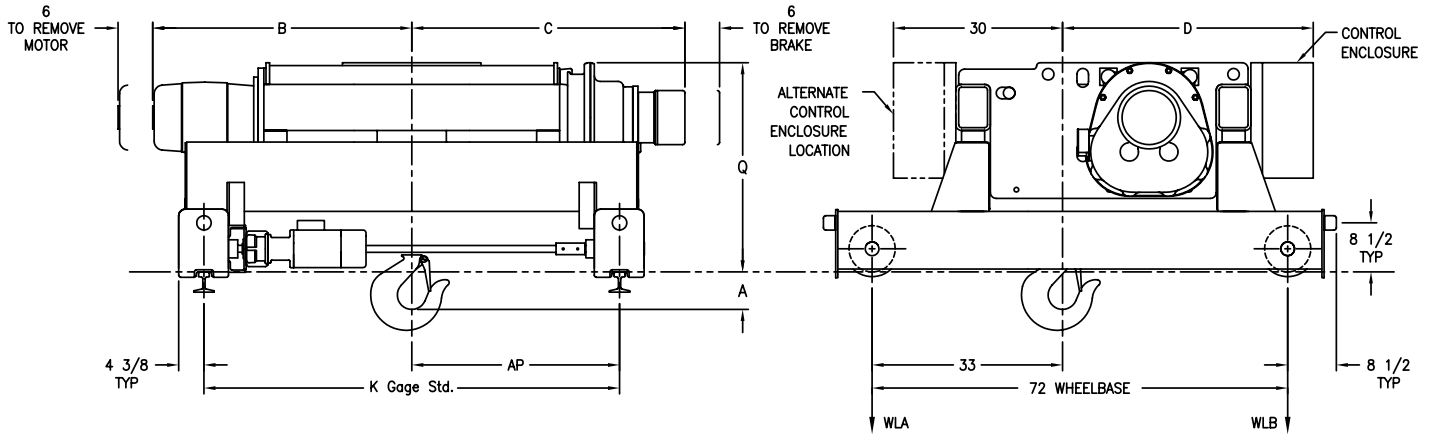

Drawing 23484312

Model Number	Lift (ft)	Speed fpm	Motor HP/RPM	Rope Dia.	Est Net Weight	WLA	WLB	A	B	C	D	K Gage Std.	AP (Gage/2)	Q	Max Rail Size (ASCE)	Wheel Tread Dia.
DEW15X29TB11D4	29	11	12-1800	7/16	4580	9206	8082	4-1/2	49	49	43	72	36	39	40#	8"
DEW15X29TB16D4	29	16	20-1800	7/16	4580	9206	8082	6-1/2	50	49	43	72	36	39	40#	8"
EEW15-33TB19D4	33	19	20-1800	7/16	5280	9331	8307	6-1/2	50	49	44	72	36	37	40#	8"
DEW15X38TB11D4	38	11	12-1800	7/16	4810	9254	8148	4-1/2	55	55	43	84	42	39	40#	8"
DEW15X38TB16D4	38	16	20-1800	7/16	4810	9254	8148	6-1/2	56	55	43	84	42	39	40#	8"
EEW15-43TB19D4	43	19	20-1800	7/16	5600	9396	8401	6-1/2	56	55	44	84	42	37	40#	8"
EEW15-61TB19D4	61	19	20-1800	7/16	6270	9532	8598	6-1/2	67	66	44	108	54	37	40#	8"

TB Trolley Speeds 50 & 75 fpm - 1 hp 1800 rpm
100 fpm - 1½ hp 1800 rpm
125 fpm - 2 hp 1800 rpm

Additional lifts, speeds and non-rotating rope available, consult factory.
Yale reserves the right to make product changes as necessary.

4 Part Double Reeving

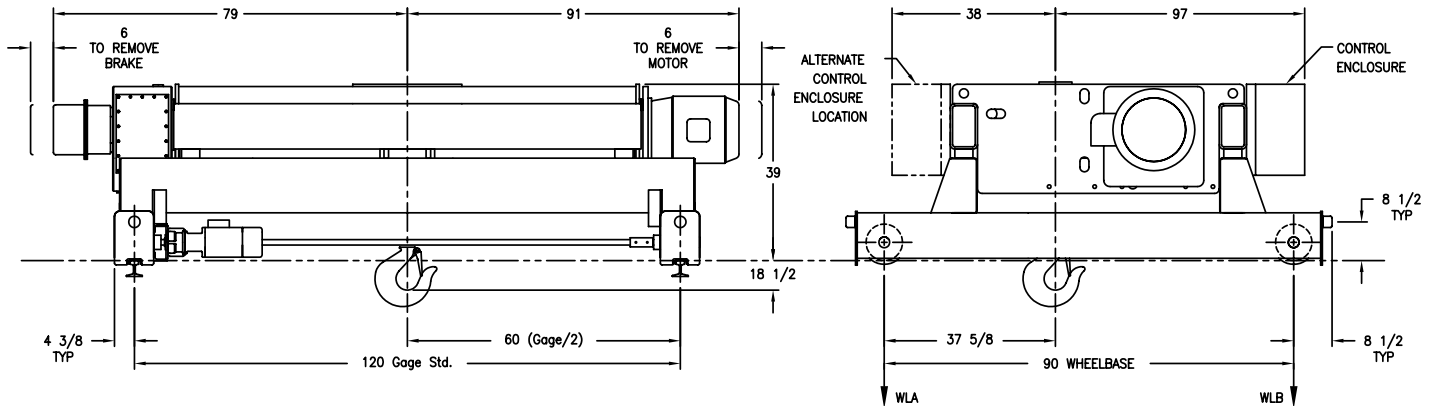

Drawing 23484313

Model Number	Lift (ft)	Speed fpm	Motor HP/RPM	Rope Dia.	Est Net Weight	WLA	WLB	Max Rail Size (ASCE)	Wheel Tread Dia.
FEW15-87TB18D4	87	18	20-1800	1/2	8250	10784	8341	40#	8"
FEW15-87TB23D4	87	23	25-1800	1/2	8570	10857	8428	40#	8"

TB Trolley Speeds 50 & 75 fpm - 1 hp 1800 rpm
 100 fpm - 1½ hp 1800 rpm
 125 fpm - 2 hp 1800 rpm

Additional lifts, speeds and non-rotating rope available, consult factory.

Yale reserves the right to make product changes as necessary.

6 Part Double Reeving

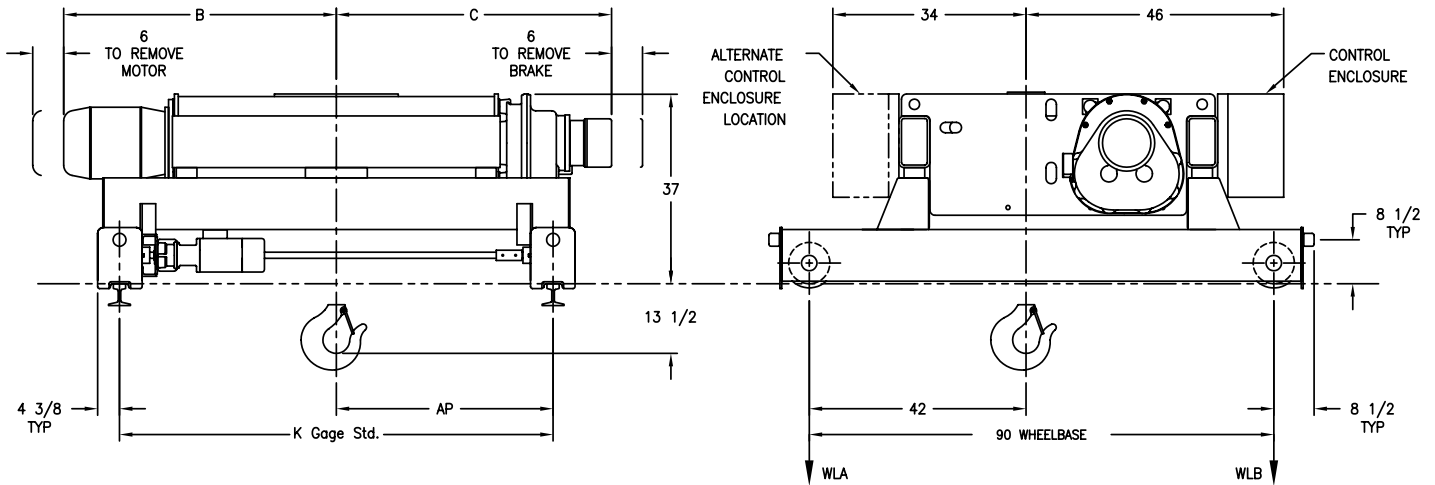

Drawing 23484314

Model Number	Lift (ft)	Speed fpm	Motor HP/RPM	Rope Dia.	Est Net Weight	WLA	WLB	B	C	K Gage Std.	AP (Gage/2)	Max Rail Size (ASCE)	Wheel Tread Dia.
EEW20-19TB8D6	19	8	12-1800	7/16	6250	12121	11003	49	49	72	36	40#	8"
EEW20-19TB13D6	19	13	20-1800	7/16	6600	12193	11106	51	49	72	36	40#	8"
EEW20-26TB8D6	26	8	12-1800	7/16	6590	12194	11101	55	55	84	42	40#	8"
EEW20-26TB13D6	26	13	20-1800	7/16	6930	12263	11201	57	55	84	42	40#	8"
EEW20-38TB13D6	38	13	20-1800	7/16	7570	12399	11383	67	65	108	52	40#	8"

TB Trolley Speeds
 50 fpm - 1 hp 1800 rpm
 75 fpm - 1½ hp 1800 rpm
 100 fpm - 2 hp 1800 rpm
 125 fpm - 3 hp 1800 rpm

Additional lifts, speeds and non-rotating rope available, consult factory.
Yale reserves the right to make product changes as necessary.

4 Part Double Reeving

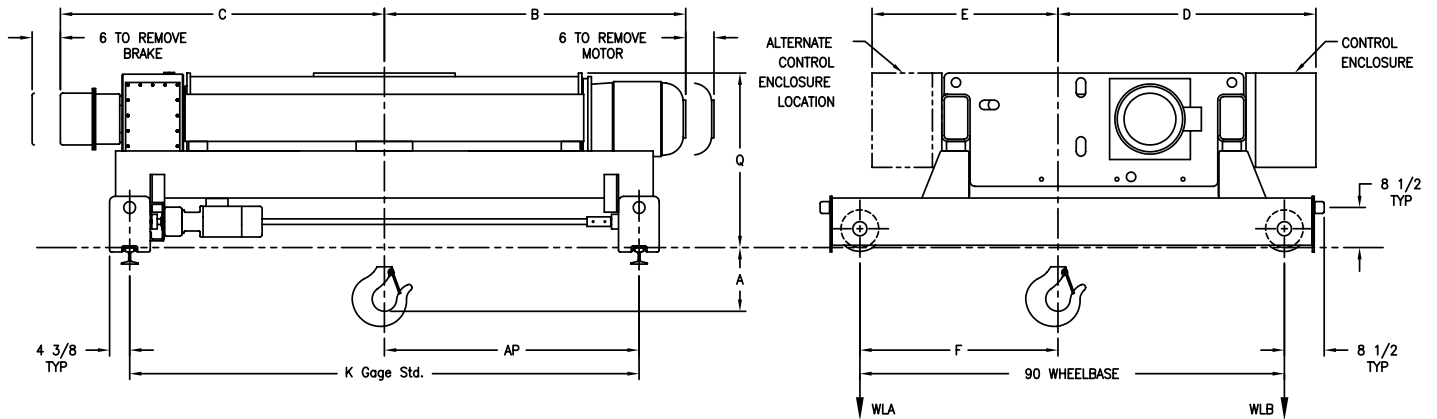

Drawing 23484315

Model Number	Lift (ft)	Speed fpm	Motor HP/RPM	Rope Dia.	Est Net Weight	WLA	WLB	A	B	C	D	E	F	K Gage Std.	AP (Gage/2)	Q	Max Rail Size (ASCE)	Wheel Tread Dia.
EEW20X22TB21D4	22	21	30-1800	1/2	6720	12163	11195	13-1/2	59	49	53	38	42	60	30	38	40#	8"
EEW20X28TB21D4	28	21	30-1800	1/2	6980	12217	11272	13-1/2	64	54	53	38	42	72	36	38	40#	8"
EEW20X37TB21D4	37	21	30-1800	1/2	7320	12286	11373	13-1/2	70	60	53	38	42	84	42	38	40#	8"
EEW20X53TB13D4	53	13	20-1800	1/2	7660	12358	11469	11-1/2	67	70	53	38	42	108	54	38	40#	8"
EEW20X53TB21D4	53	21	30-1800	1/2	7960	12416	11560	13-1/2	80	70	53	38	42	108	54	38	40#	8"
FEW20-75TB14D4	75	14	20-1800	1/2	8580	12858	11429	20-1/2	83	79	55	37	40-1/2	120	60	37	40#	8"
FEW20-75TB23D4	75	23	30-1800	1/2	9000	12946	11553	20-1/2	95	79	55	37	40-1/2	144	72	37	40#	8"
FEW20-92TB15D4	92	15	20-1200	1/2	8910	12929	11525	20-1/2	87	89	55	37	40-1/2	144	72	37	40#	8"

TB Trolley Speeds
 50 fpm - 1 hp 1800 rpm
 75 fpm - 1½ hp 1800 rpm
 100 fpm - 2 hp 1800 rpm
 125 fpm - 3 hp 1800 rpm

Additional lifts, speeds and non-rotating rope available, consult factory.
Yale reserves the right to make product changes as necessary.

2 Part Double Reeving

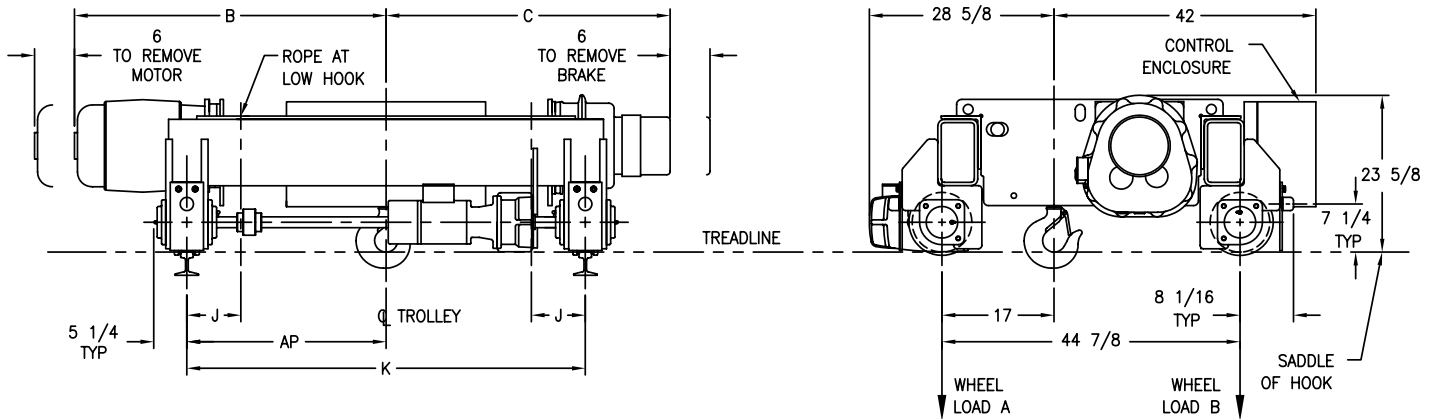

Drawing 23484401

Model Number	Lift (ft)	Speed fpm	Motor HP/RPM	Rope Dia.	Est Net Weight	WLA	WLB	B	C	J	K Gage Std.	AP (Gage/2)	Max Rail Size (ASCE)	Wheel Tread Dia.
CEW5X24TR19D2	24	19	7.5-1200	3/8	2830	2923	2527	38	34	31-1/8	48	24	60#	9"
CEW5X24TR28D2	24	28	10-1800	3/8	2830	2923	2527	38	34	31-1/8	48	24	60#	9"
CEW5X32TR19D2	32	19	7.5-1200	3/8	2870	3931	2539	41	37	10-1/8	48	24	60#	9"
CEW5X32TR28D2	32	28	10-1800	3/8	2870	3931	2539	41	37	10-1/8	48	24	60#	9"
CEW5X41TR19D2	41	19	7.5-1200	3/8	2920	3941	2554	45	40	6-5/8	48	24	60#	9"
CEW5X41TR28D2	41	28	10-1800	3/8	2920	3941	2554	45	40	6-5/8	48	24	60#	9"
CEW5X54TR19D2	54	19	7.5-1200	3/8	3100	3990	2603	49	45	8-1/8	60	30	60#	9"
CEW5X54TR28D2	54	28	10-1800	3/8	3100	3990	2603	49	45	8-1/8	60	30	60#	9"

TR Trolley Speeds
 50 fpm - 1/2 hp 1800 rpm
 75 fpm - 3/4 hp 1800 rpm
 100 fpm - 1 hp 1800 rpm

Additional lifts, speeds and non-rotating rope available, consult factory.
Yale reserves the right to make product changes as necessary.

2 Part Double Reeving

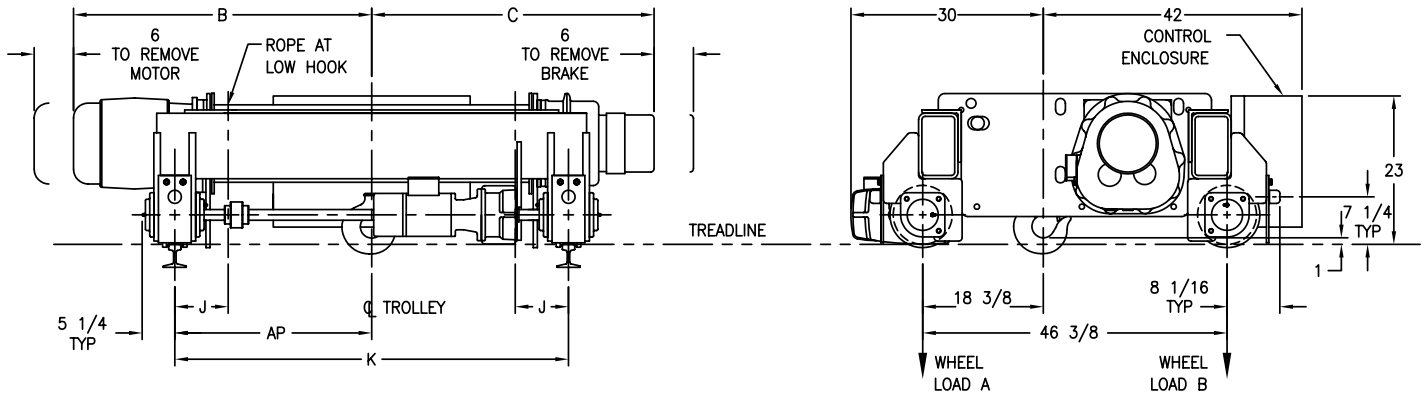

Drawing 23484402

Model Number	Lift (ft)	Speed fpm	Motor HP/RPM	Rope Dia.	Est Net Weight	WLA	WLB	B	C	J	K Gage Std.	AP (Gage/2)	Max Rail Size (ASCE)	Wheel Tread Dia.
DEW5-71TR20D2	71	20	7.5-1200	3/8	3140	3791	2821	47	45	8-1/8	60	30	60#	9"
DEW5-71TR30D2	71	30	15-1800	3/8	3140	3791	2821	47	45	8-1/8	60	30	60#	9"
DEW5-94TR30D2	94	30	15-1800	3/8	3440	3863	2907	54	52	7-5/8	72	36	60#	9"

TR Trolley Speeds
 50 fpm - 1/2 hp 1800 rpm
 75 fpm - 3/4 hp 1800 rpm
 100 fpm - 1 hp 1800 rpm

Additional lifts, speeds and non-rotating rope available, consult factory.
Yale reserves the right to make product changes as necessary.

2 Part Double Reeving

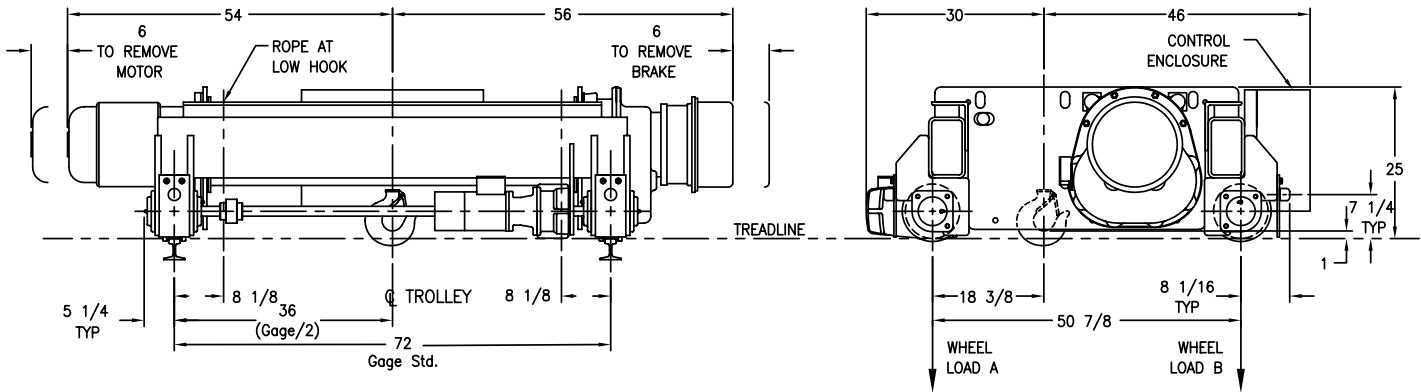

Drawing 23484403

Model Number	Lift (ft)	Speed fpm	Motor HP/RPM	Rope Dia.	Est Net Weight	WLA	WLB	Max Rail Size (ASCE)	Wheel Tread Dia.
EEW5-105TR50D2	105	50	20-1800	3/8	4620	4273	3084	60#	9"

TR Trolley Speeds
 50 fpm - 1/2 hp 1800 rpm
 75 fpm - 3/4 hp 1800 rpm
 100 fpm - 1 hp 1800 rpm

Additional lifts, speeds and non-rotating rope available, consult factory.
Yale reserves the right to make product changes as necessary.

4 Part Double Reeving

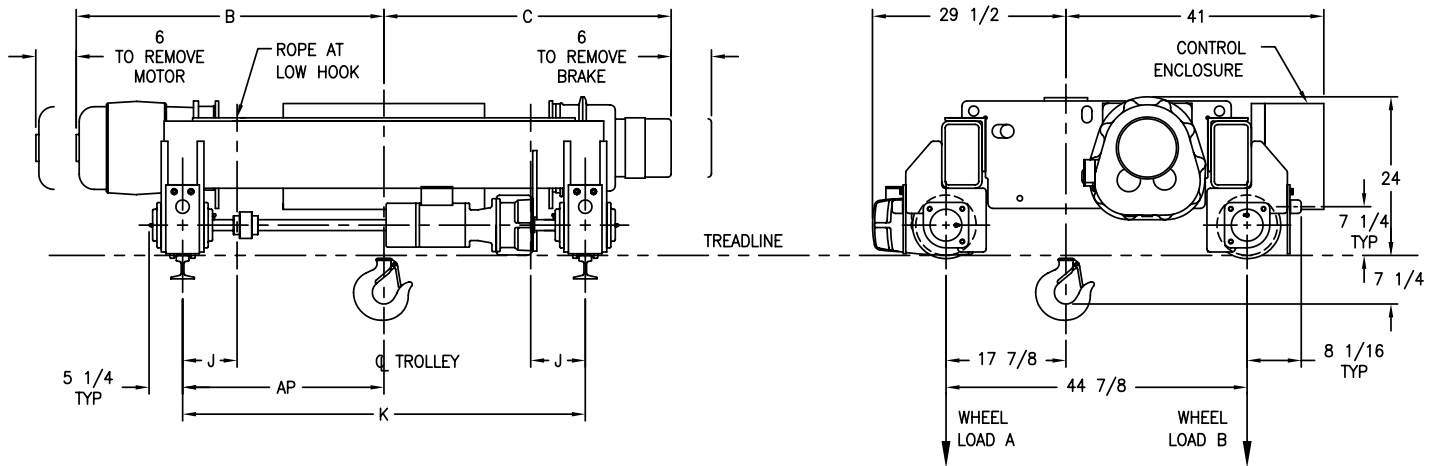

Drawing 23484404

Model Number	Lift (ft)	Speed fpm	Motor HP/ RPM	Rope Dia.	Est Net Weight	WLA	WLB	B	C	J	K Gage Std.	AP (Gage/2)	Max Rail Size (ASCE)	Wheel Tread Dia.
CEW7.5X19TR8D4	19	8	5-1200	5/16	2760	5384	3531	38	37	10-1/8	48	24	60#	9"
CEW7.5X19TR14D4	19	14	7.5-1800	5/16	2760	5384	3531	41	37	10-1/8	48	24	60#	9"
CEW7.5X25TR8D4	25	8	5-1200	5/16	2830	5398	3552	42	40	6-5/8	48	24	60#	9"
CEW7.5X25TR14D4	25	14	7.5-1800	5/16	2830	5398	3552	45	40	6-5/8	48	24	60#	9"
CEW7.5X32TR8D4	32	8	5-1200	5/16	3050	5455	3613	46	45	8-1/8	60	30	60#	9"
CEW7.5X32TR14D4	32	14	7.5-1800	5/16	3050	5455	3613	49	45	8-1/8	60	30	60#	9"

TR Trolley Speeds
 50 fpm - 3/4 hp 1800 rpm
 75 fpm - 1 hp 1800 rpm
 100 fpm - 1 hp 1800 rpm

Additional lifts, speeds and non-rotating rope available, consult factory.

Yale reserves the right to make product changes as necessary.

4 Part Double Reeving

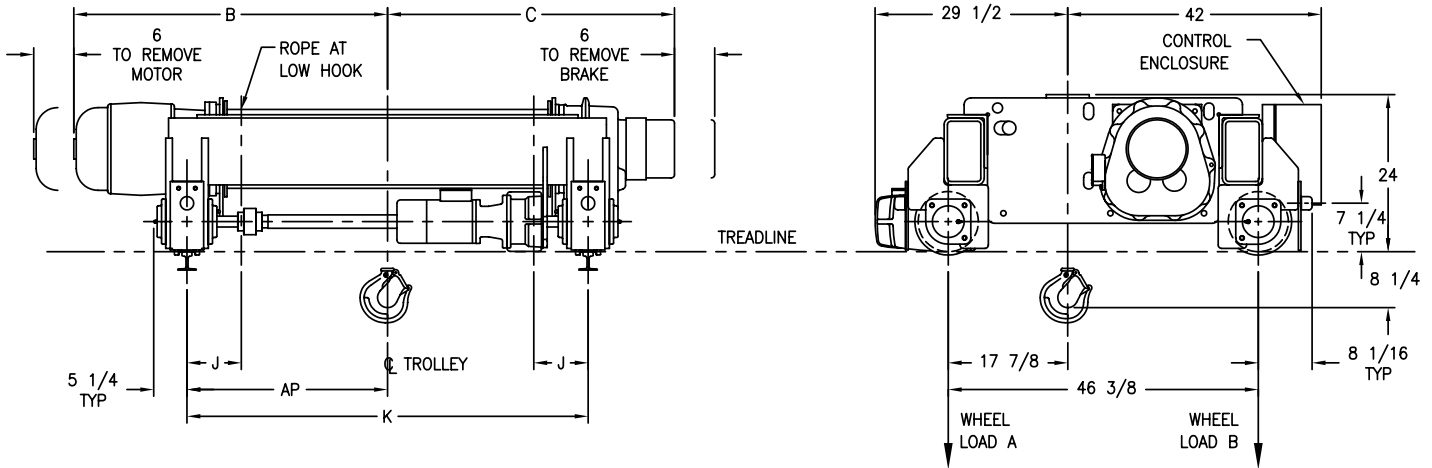

Drawing 23484405

Model Number	Lift (ft)	Speed fpm	Motor HP/RPM	Rope Dia.	Est Net Weight	WLA	WLB	B	C	J	K Gage Std.	AP (Gage/2)	Max Rail Size (ASCE)	Wheel Tread Dia.
DEW7.5-19TR19D4	19	19	10-1800	5/16	2920	5326	3669	36	34	13-1/8	48	24	60#	9"
DEW7.5-25TR19D4	25	19	10-1800	5/16	3000	5341	3693	39	37	10-1/8	48	24	60#	9"
DEW7.5-32TR19D4	32	19	10-1800	5/16	3080	5357	3717	43	41	6-5/8	48	24	60#	9"
DEW7.5-42TR19D4	42	19	10-1800	5/16	3310	5416	3781	47	45	8-1/8	60	30	60#	9"
DEW7.5-55TR19D4	55	19	10-1800	5/16	3580	5481	3856	54	52	7-5/8	72	36	60#	9"

TR Trolley Speeds 50 fpm - 3/4 hp 1800 rpm
 75 fpm - 1 hp 1800 rpm
 100 fpm - 1 hp 1800 rpm

Additional lifts, speeds and non-rotating rope available, consult factory.

Yale reserves the right to make product changes as necessary.

2 Part Double Reeving

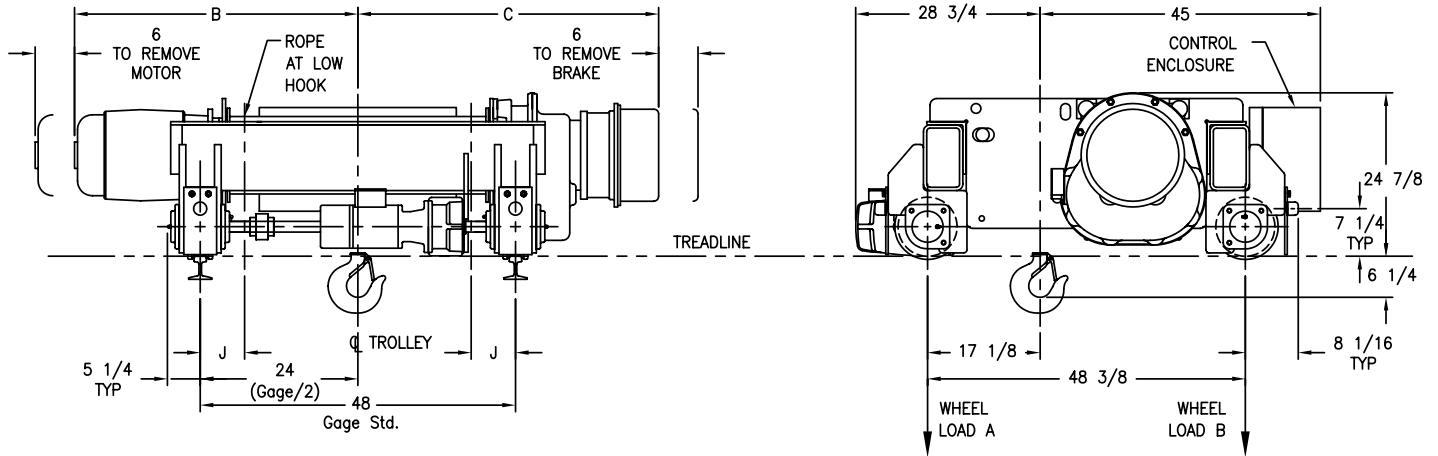

Drawing 23484406

Model Number	Lift (ft)	Speed fpm	Motor HP/RPM	Rope Dia.	Est Net Weight	WLA	WLB	B	C	J	Max Rail Size (ASCE)	Wheel Tread Dia.
DEW7.5X28TR33D2	28	33	20-1800	7/16	3190	5616	3514	39	40	13-1/4	60#	9"
DEW7.5X37TR33D2	37	33	20-1800	7/16	3260	5630	3535	42	43	10-1/4	60#	9"
DEW7.5X47TR33D2	47	33	20-1800	7/16	3350	5648	3562	45	46	6-3/4	60#	9"

TR Trolley Speeds 50 fpm - 3/4 hp 1800 rpm
 75 fpm - 1 hp 1800 rpm
 100 fpm - 1 hp 1800 rpm

Additional lifts, speeds and non-rotating rope available, consult factory.
Yale reserves the right to make product changes as necessary.

2 Part Double Reeving

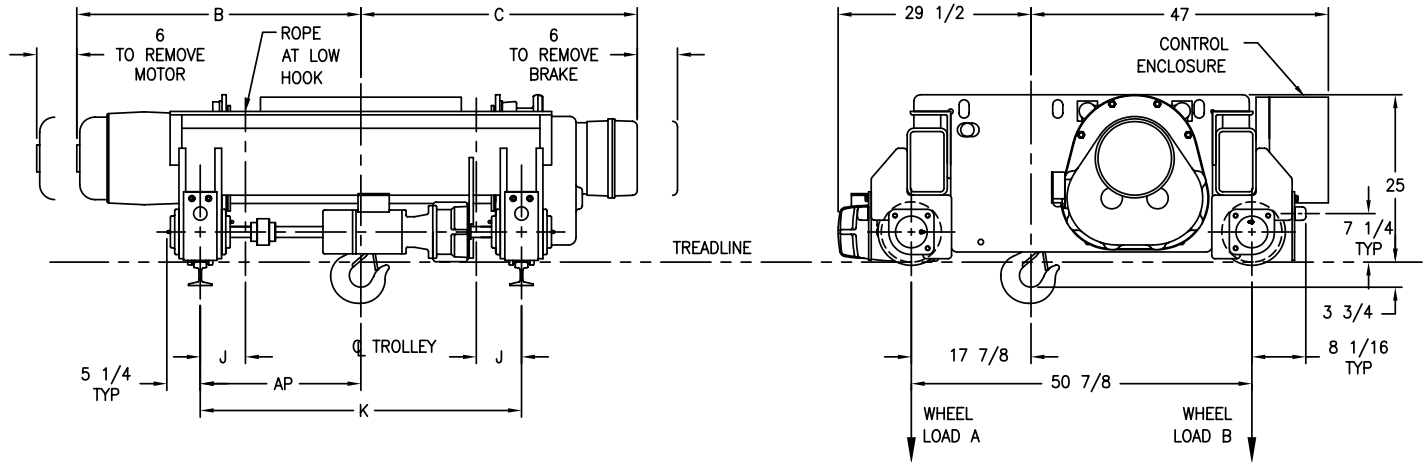

Drawing 23484407

Model Number	Lift (ft)	Speed fpm	Motor HP/RPM	Rope Dia.	Est Net Weight	WLA	WLB	B	C	J	K Gage Std.	AP (Gage/2)	Max Rail Size (ASCE)	Wheel Tread Dia.
EEW7.5-32TR25D2	32	25	15-1800	7/16	3450	5687	3573	38	38	13-3/8	48	24	60#	9"
EEW7.5-43TR25D2	43	25	15-1800	7/16	3561	5709	3606	41	41	10-3/8	48	24	60#	9"
EEW7.5-55TR25D2	55	25	15-1800	7/16	3690	5735	3645	44	44	6-7/8	48	24	60#	9"
EEW7.5-71TR25D2	71	25	15-1800	7/16	3990	5808	3729	49	49	8-3/8	60	30	60#	9"
EEW7.5-91TR25D2	91	25	15-1800	7/16	4320	5885	3822	55	55	8-3/8	72	36	60#	9"
EEW7.5-128TR38D2	128	38	20-1800	7/16	5340	6110	4116	67	65	9-7/8	96	48	60#	9"

TR Trolley Speeds
 50 fpm - 3/4 hp 1800 rpm
 75 fpm - 1 hp 1800 rpm
 100 fpm - 1 hp 1800 rpm

Additional lifts, speeds and non-rotating rope available, consult factory.
Yale reserves the right to make product changes as necessary.

2 Part Double Reeving

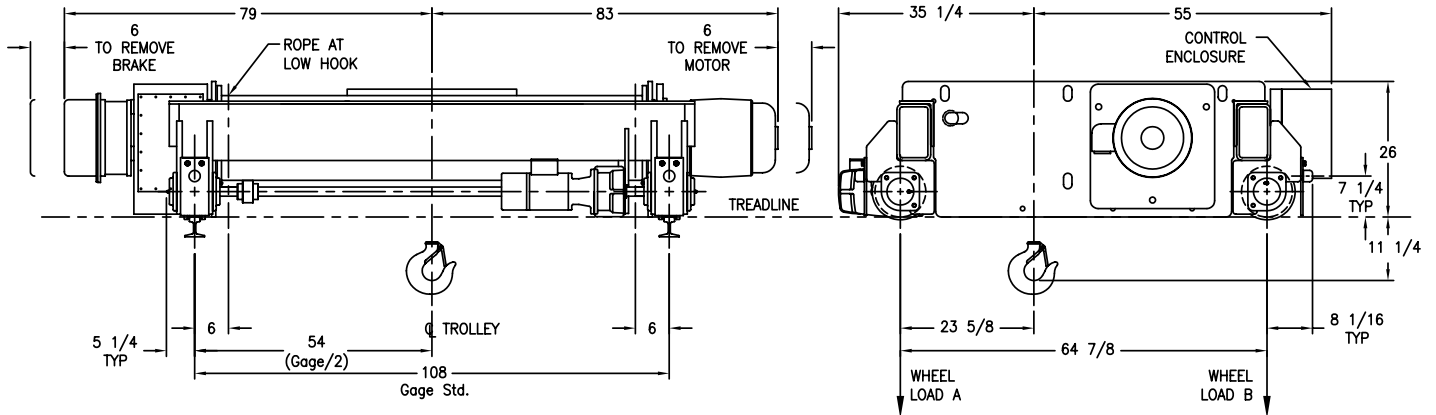

Drawing 23484408

Model Number	Lift (ft)	Speed fpm	Motor HP/RPM	Rope Dia.	Est Net Weight	WLA	WLB	Max Rail Size (ASCE)	Wheel Tread Dia.
FEW7.5-173TR35D2	173	35	20-1800	7/16	7250	6402	4781	60#	9"

TR Trolley Speeds
 50 fpm - 3/4 hp 1800 rpm
 75 fpm - 1 hp 1800 rpm
 100 fpm - 1 hp 1800 rpm

Additional lifts, speeds and non-rotating rope available, consult factory.
Yale reserves the right to make product changes as necessary.

4 Part Double Reeving

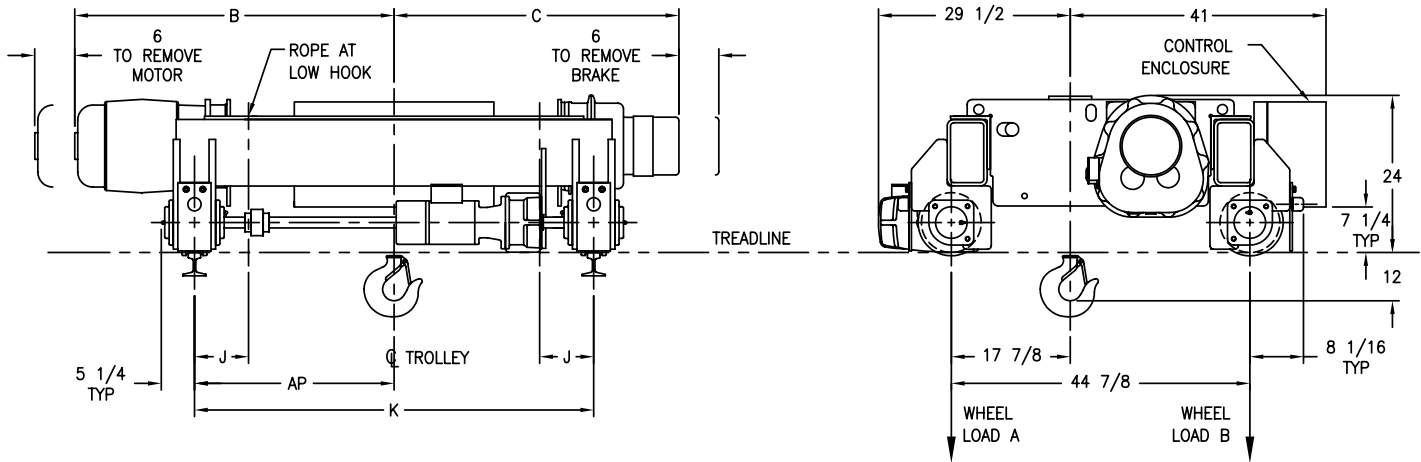

Drawing 23484409

Model Number	Lift (ft)	Speed fpm	Motor HP/RPM	Rope Dia.	Est Net Weight	WLA	WLB	B	C	J	K Gage Std.	AP (Gage/2)	Max Rail Size (ASCE)	Wheel Tread Dia.
CEW10X20TR8D4	20	8	7.5-1200	3/8	2950	6989	4521	45	40	6-5/8	48	24	60#	9"
CEW10X20TR14D4	20	14	10-1800	3/8	2950	6989	4521	45	40	6-5/8	48	24	60#	9"
CEW10X25TR8D4	25	8	7.5-1200	3/8	3170	7046	4582	49	45	8-1/8	60	30	60#	9"
CEW10X25TR14D4	25	14	10-1800	3/8	3170	7046	4582	49	45	8-1/8	60	30	60#	9"

TR Trolley Speeds
 50 fpm - 3/4 hp 1800 rpm
 75 fpm - 1 hp 1800 rpm
 100 fpm - 1 1/2 hp 1800 rpm

Additional lifts, speeds and non-rotating rope available, consult factory.
Yale reserves the right to make product changes as necessary.

4 Part Double Reeving

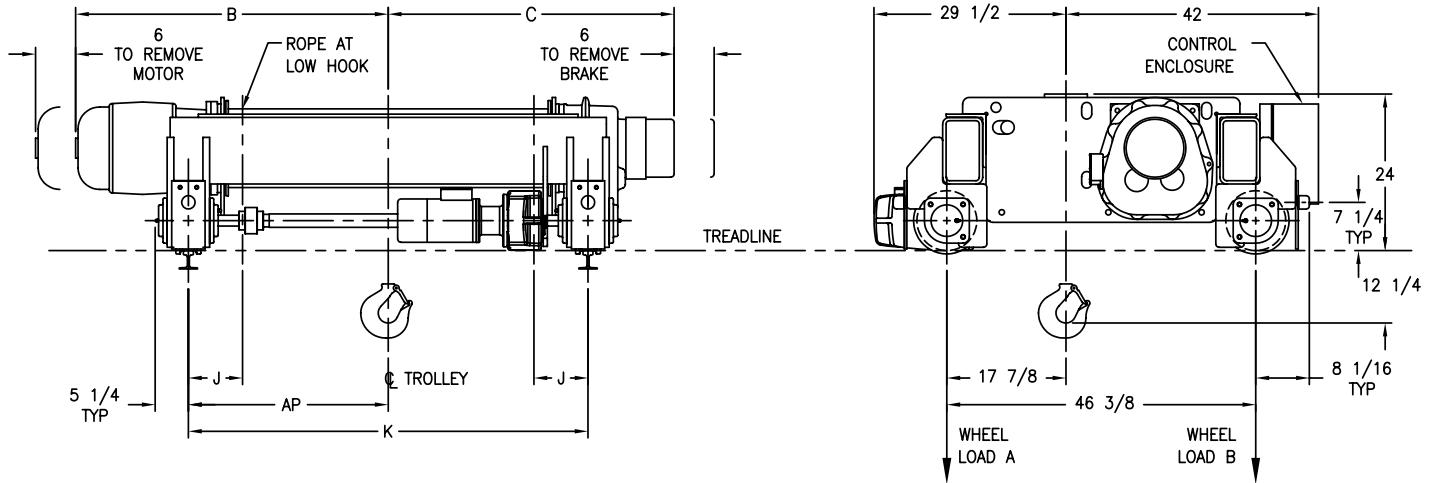

Drawing 23484410

Model Number	Lift (ft)	Speed fpm	Motor HP/RPM	Rope Dia.	Est Net Weight	WLA	WLB	B	C	J	K Gage Std.	AP (Gage/2)	Max Rail Size (ASCE)	Wheel Tread Dia.
DEW10-35TR15D4	35	15	10-1800	3/8	3400	6971	4772	47	45	8-1/8	60	30	60#	9"
DEW10-46TR15D4	46	15	10-1800	3/8	3690	7040	4853	54	52	7-5/8	72	36	60#	9"

TR Trolley Speeds
 50 fpm - 3/4 hp 1800 rpm
 75 fpm - 1 hp 1800 rpm
 100 fpm - 1 1/2 hp 1800 rpm

Additional lifts, speeds and non-rotating rope available, consult factory.
Yale reserves the right to make product changes as necessary.

4 Part Double Reeving

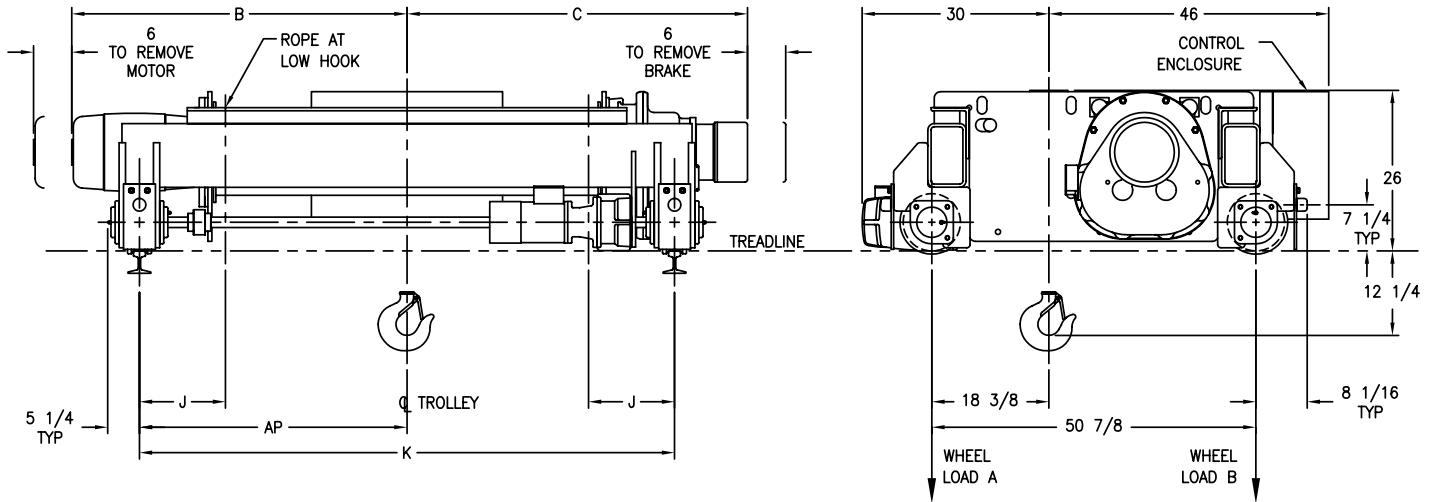

Drawing 23484411

Model Number	Lift (ft)	Speed fpm	Motor HP/RPM	Rope Dia.	Est Net Weight	WLA	WLB	B	C	J	K Gage Std.	AP (Gage/2)	Max Rail Size (ASCE)	Wheel Tread Dia.
EEW10-23TR19D4	23	19	15-1800	3/8	4240	7368	4786	41	41	10-1/8	48	24	60#	9"
EEW10-23TR25D4	23	25	20-1800	3/8	4240	7368	4786	43	43	10-1/8	48	24	60#	9"
EEW10-30TR19D4	30	19	15-1800	3/8	4390	7398	4831	44	44	6-5/8	48	24	60#	9"
EEW10-30TR25D4	30	25	20-1800	3/8	4390	7398	4831	46	46	6-5/8	48	24	60#	9"
EEW10-38TR19D4	38	19	15-1800	3/8	4700	7473	4919	49	49	8-1/8	60	30	60#	9"
EEW10-38TR25D4	38	25	20-1800	3/8	4700	7473	4919	51	51	8-1/8	60	30	60#	9"

TR Trolley Speeds
 50 fpm - 3/4 hp 1800 rpm
 75 fpm - 1 hp 1800 rpm
 100 fpm - 1 1/2 hp 1800 rpm

Additional lifts, speeds and non-rotating rope available, consult factory.

Yale reserves the right to make product changes as necessary.

4 Part Double Reeving

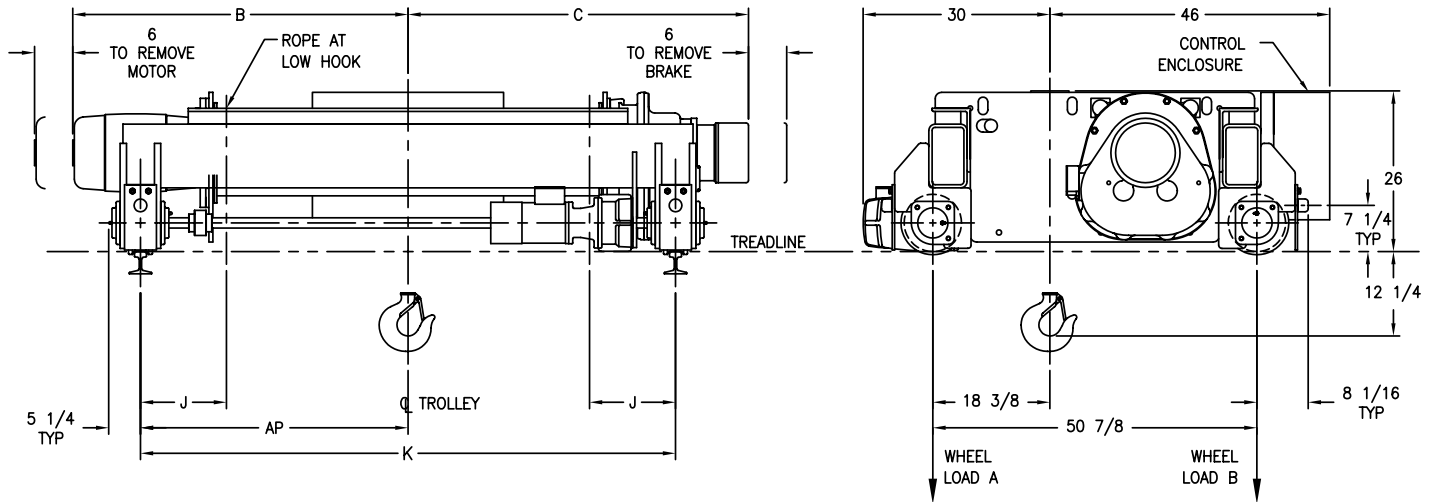

Drawing 23484412

Model Number	Lift (ft)	Speed fpm	Motor HP/RPM	Rope Dia.	Est Net Weight	WLA	WLB	B	C	J	K Gage Std.	AP (Gage/2)	Max Rail Size (ASCE)	Wheel Tread Dia.
EEW10-50TR19D4	50	19	15-1800	3/8	5050	7554	5018	55	55	8-1/8	72	36	60#	9"
EEW10-50TR25D4	50	25	20-1800	3/8	5050	7554	5018	57	57	8-1/8	72	36	60#	9"
EEW10-71TR19D4	71	19	15-1800	3/8	5690	7703	5198	65	65	9-5/8	96	48	60#	9"
EEW10-71TR25D4	71	25	20-1800	3/8	5690	7703	5198	67	67	9-5/8	96	48	60#	9"

TR Trolley Speeds 50 fpm - ¾ hp 1800 rpm
 75 fpm - 1 hp 1800 rpm
 100 fpm - 1½ hp 1800 rpm

Additional lifts, speeds and non-rotating rope available, consult factory.
Yale reserves the right to make product changes as necessary.

2 Part Double Reeving

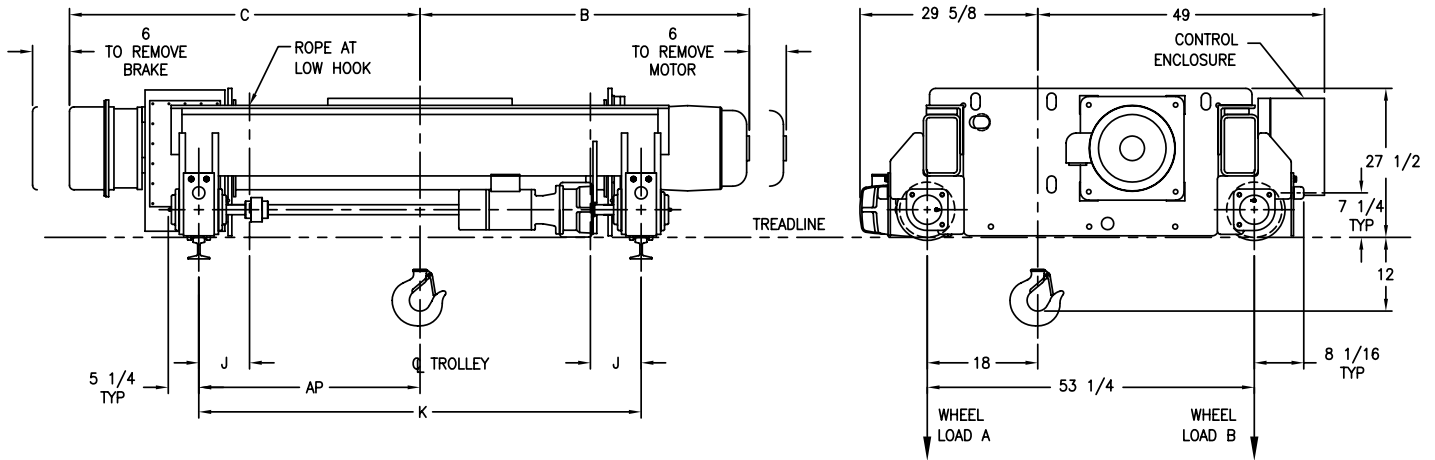

Drawing 23484413

Model Number	Lift (ft)	Speed fpm	Motor HP/RPM	Rope Dia.	Est Net Weight	WLA	WLB	B	C	J	K Gage Std.	AP (Gage/2)	Max Rail Size (ASCE)	Wheel Tread Dia.
EEW10X33TR26D2	33	26	20-1800	1/2	4460	7644	4621	43	46	10-1/4	48	24	60#	9"
EEW10X44TR26D2	44	26	20-1800	1/2	4590	7670	4660	46	49	6-3/4	48	24	60#	9"
EEW10X57TR26D2	57	26	20-1800	1/2	4700	7705	4687	51	54	8-1/4	60	30	60#	9"
EEW10X75TR26D2	75	26	20-1800	1/2	5260	7828	4849	57	60	8-1/4	72	36	60#	9"
EEW10X106TR19D2	106	19	15-1800	1/2	5810	7960	5002	67	70	9-3/4	96	48	60#	9"
EEW10X106TR26D2	106	26	20-1800	1/2	5810	7960	5002	67	70	9-3/4	96	48	60#	9"

TR Trolley Speeds
 50 fpm - ¾ hp 1800 rpm
 75 fpm - 1 hp 1800 rpm
 100 fpm - 1½ hp 1800 rpm

Additional lifts, speeds and non-rotating rope available, consult factory.

Yale reserves the right to make product changes as necessary.

2 Part Double Reeving

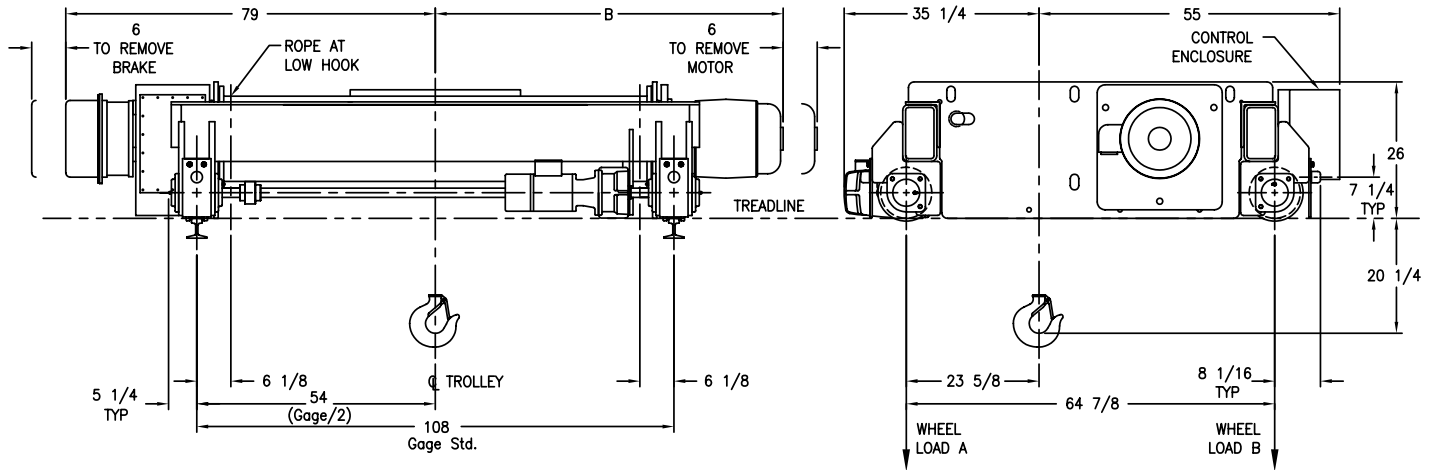

Drawing 23484414

Model Number	Lift (ft)	Speed fpm	Motor HP/RPM	Rope Dia.	Est Net Weight	WLA	WLB	B	Max Rail Size (ASCE)	Wheel Tread Dia.
FEW10-150TR21D2	150	21	15-1800	1/2	7210	7985	5679	79	60#	9"
FEW10-150TR29D2	150	29	20-1800	1/2	7210	7985	5679	83	60#	9"

TR Trolley Speeds
50 fpm - 3/4 hp 1800 rpm
75 fpm - 1 hp 1800 rpm
100 fpm - 1 1/2 hp 1800 rpm

Additional lifts, speeds and non-rotating rope available, consult factory.
Yale reserves the right to make product changes as necessary.

4 Part Double Reeving

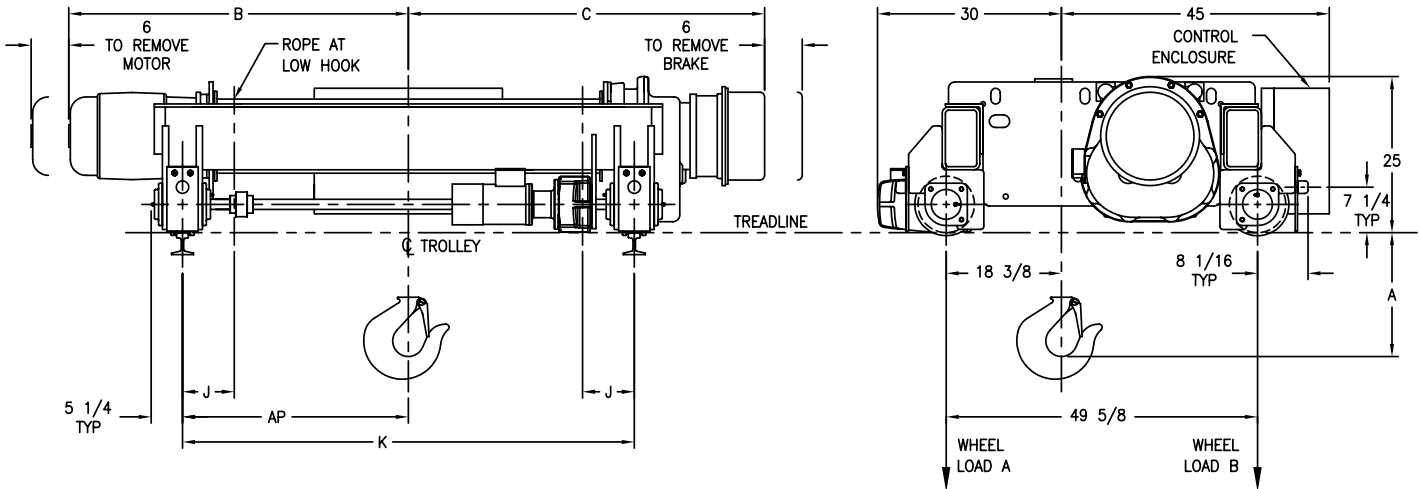

Drawing 23484415

Model Number	Lift (ft)	Speed fpm	Motor HP/RPM	Rope Dia.	Est Net Weight	WLA	WLB	B	C	J	K Gage Std.	AP (Gage/2)	Max Rail Size (ASCE)	Wheel Tread Dia.
DEW15X22TR11D4	22	11	12-1800	7/16	3730	10324	6575	44	44	6-3/4	48	24	60#	9"
DEW15X22TR16D4	22	16	20-1800	7/16	3730	10324	6575	45	46	6-3/4	48	24	60#	9"
DEW15X29TR11D4	29	11	12-1800	7/16	3970	10385	6642	49	48	8-1/4	60	30	60#	9"
DEW15X29TR16D4	29	16	20-1800	7/16	3970	10385	6642	50	50	8-1/4	60	30	60#	9"
DEW15X38TR11D4	38	11	12-1800	7/16	4250	10452	6720	55	55	7-3/4	72	36	60#	9"
DEW15X38TR16D4	38	16	20-1800	7/16	4250	10452	6720	56	57	7-3/4	72	36	60#	9"

TR Trolley Speeds
 50 fpm - 1 hp 1800 rpm
 75 fpm - 1½ hp 1800 rpm
 100 fpm - 2 hp 1800 rpm

Additional lifts, speeds and non-rotating rope available, consult factory.
Yale reserves the right to make product changes as necessary.

4 Part Double Reeving

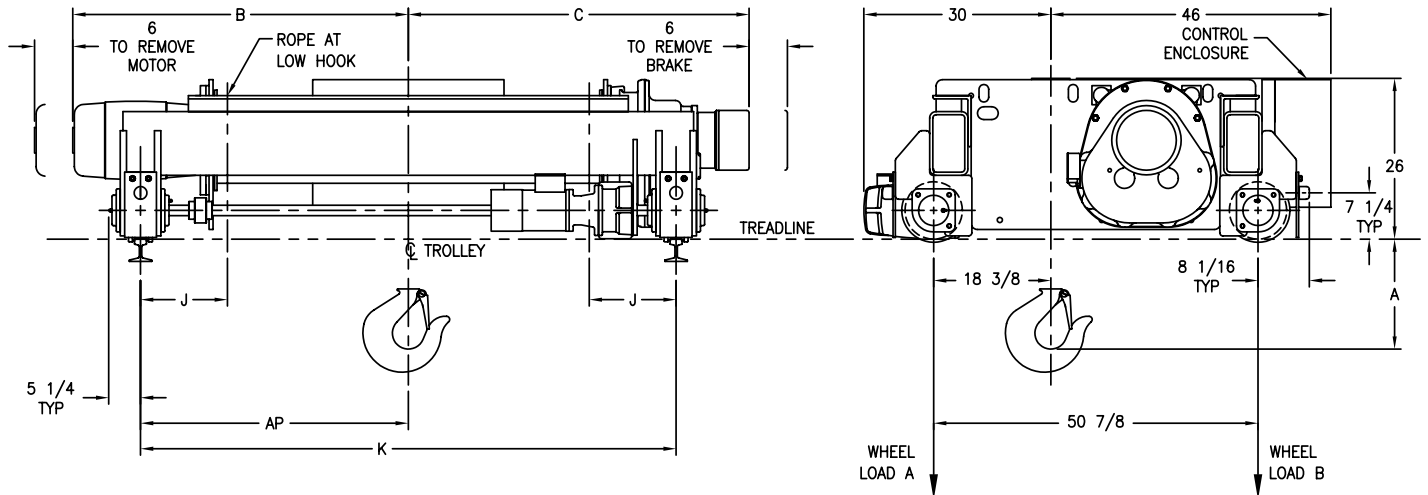

Drawing 23484416

Model Number	Lift (ft)	Speed fpm	Motor HP/RPM	Rope Dia.	Est Net Weight	WLA	WLB	B	C	J	K Gage Std.	AP (Gage/2)	Max Rail Size (ASCE)	Wheel Tread Dia.
EEW15-25TR12D4	25	12	12-1800	7/16	4340	10583	6622	44	44	6-3/4	48	24	60#	9"
EEW15-25TR19D4	25	19	20-1800	7/16	4340	10583	6622	45	44	6-3/4	48	24	60#	9"
EEW15-33TR12D4	33	12	12-1800	7/16	4670	10662	6716	49	49	8-1/4	60	30	60#	9"
EEW15-33TR19D4	33	19	20-1800	7/16	4670	10662	6716	50	49	8-1/4	60	30	60#	9"
EEW15-43TR12D4	43	12	12-1800	7/16	5040	10747	6821	55	55	8-1/4	72	36	60#	9"
EEW15-43TR19D4	43	19	20-1800	7/16	5040	10747	6821	56	55	8-1/4	72	36	60#	9"
EEW15-61TR12D4	61	12	12-1800	7/16	5810	10922	7039	66	66	9-3/4	96	48	60#	9"
EEW15-61TR19D4	61	19	20-1800	7/16	5810	10922	7039	67	66	9-3/4	96	48	60#	9"

TR Trolley Speeds
 50 fpm - 1 hp 1800 rpm
 75 fpm - 1½ hp 1800 rpm
 100 fpm - 2 hp 1800 rpm

Additional lifts, speeds and non-rotating rope available, consult factory.

Yale reserves the right to make product changes as necessary.

4 Part Double Reeving

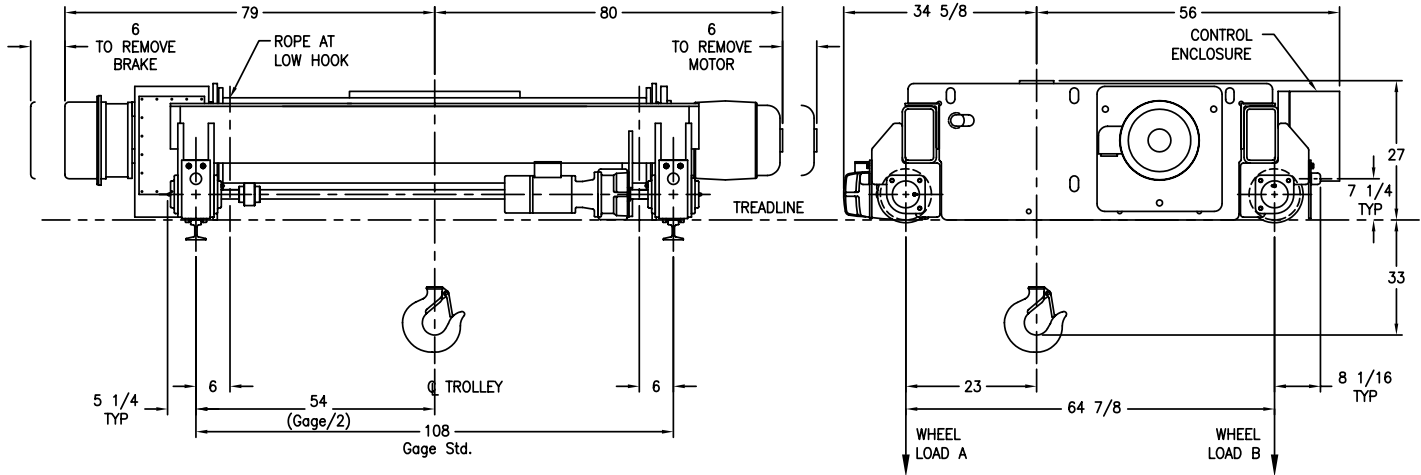

Drawing 23484417

Model Number	Lift (ft)	Speed fpm	Motor HP/RPM	Rope Dia.	Est Net Weight	WLA	WLB	Max Rail Size (ASCE)	Wheel Tread Dia.
FEW15-87TR18D4	87	18	20-1800	7/16	7710	11410	7504	60#	9"

TR Trolley Speeds
 50 fpm - 1 hp 1800 rpm
 75 fpm - 1½ hp 1800 rpm
 100 fpm - 2 hp 1800 rpm

Additional lifts, speeds and non-rotating rope available, consult factory.
Yale reserves the right to make product changes as necessary.

4 Part Double Reeving

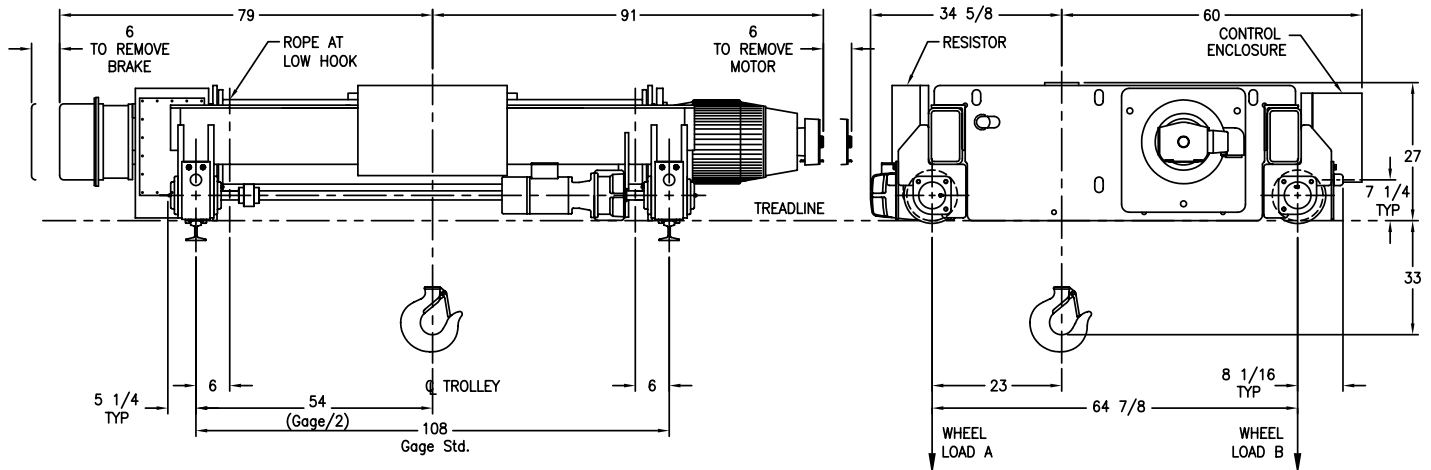

Drawing 23484418

Model Number	Lift (ft)	Speed fpm	Motor HP/RPM	Rope Dia.	Est Net Weight	WLA	WLB	Max Rail Size (ASCE)	Wheel Tread Dia.
FEW15-87TR23D4	87	23	25-1800	7/16	8030	11473	7600	60#	9"

TR Trolley Speeds
 50 fpm - 1 hp 1800 rpm
 75 fpm - 1½ hp 1800 rpm
 100 fpm - 2 hp 1800 rpm

Additional lifts, speeds and non-rotating rope available, consult factory.
Yale reserves the right to make product changes as necessary.

6 Part Double Reeving

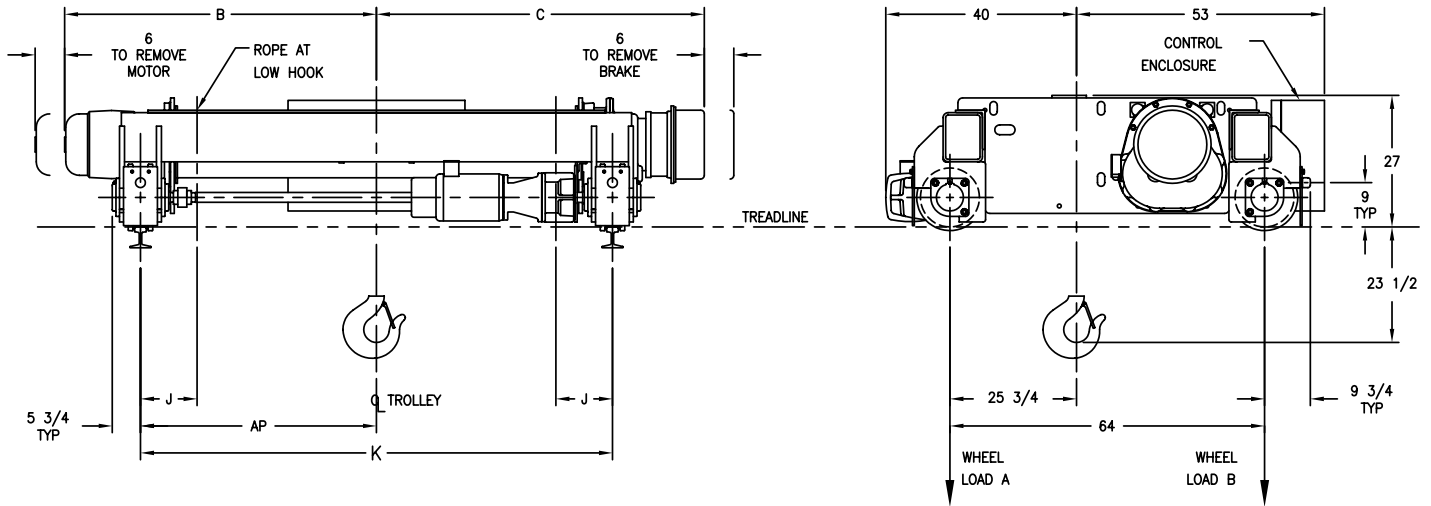

Drawing 23484419

Model Number	Lift (ft)	Speed fpm	Motor HP/RPM	Rope Dia.	Est Net Weight	WLA	WLB	B	C	J	K Gage Std.	AP (Gage/2)	Max Rail Size (ASCE)	Wheel Tread Dia.
EEW20-19TR8D6	19	8	12-1800	7/16	7000	13574	9986	49	51	8-1/4	60	30	85#	12"
EEW20-19TR13D6	19	13	20-1800	7/16	7000	13574	9986	51	51	8-1/4	60	30	85#	12"
EEW20-26TR8D6	26	8	12-1800	7/16	7420	13671	10105	55	57	8-1/4	72	36	85#	12"
EEW20-26TR13D6	26	13	20-1800	7/16	7420	13671	10105	57	57	8-1/4	72	36	85#	12"
EEW20-38TR13D6	38	13	20-1800	7/16	8200	13848	10324	67	68	9-3/4	96	48	85#	12"

TR Trolley Speeds
 60 fpm - 1½ hp 1800 rpm
 70 fpm - 2 hp 1800 rpm
 90 fpm - 3 hp 1800 rpm

Additional lifts, speeds and non-rotating rope available, consult factory.
Yale reserves the right to make product changes as necessary.

4 Part Double Reeving

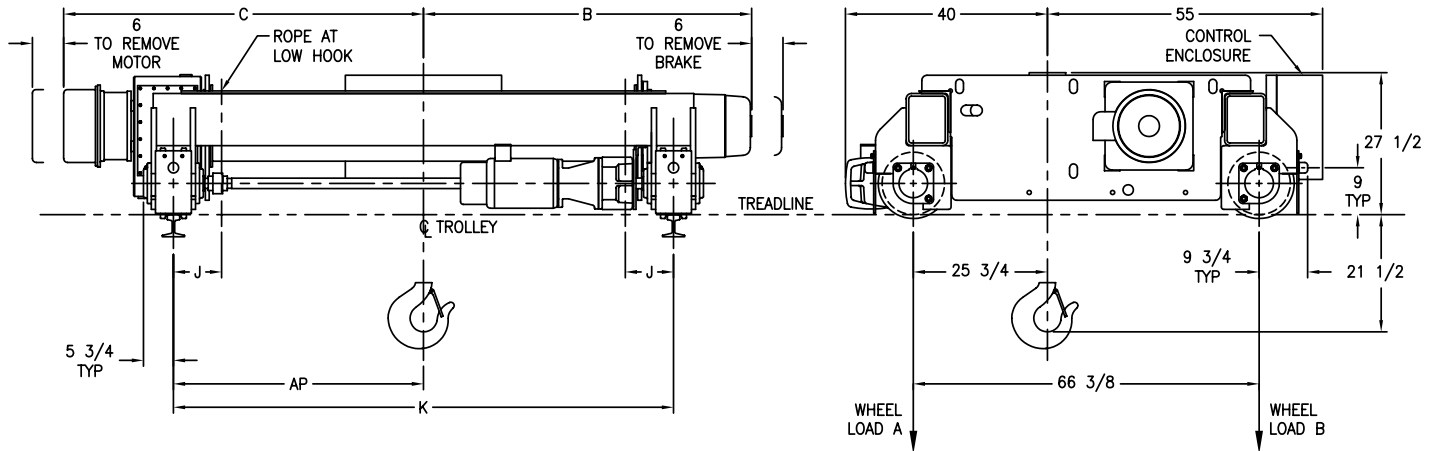

Drawing 23484420

Model Number	Lift (ft)	Speed fpm	Motor HP/RPM	Rope Dia.	Est Net Weight	WLA	WLB	B	C	J	K Gage Std.	AP (Gage/2)	Max Rail Size (ASCE)	Wheel Tread Dia.
EEW20X22TR9D4	22	9	12-1800	1/2	6770	13801	9631	45	49	6-1/2	48	24	85#	12"
EEW20X22TR13D4	22	13	20-1800	1/2	6770	13801	9631	45	49	6-1/2	48	24	85#	12"
EEW20X28TR9D4	28	9	12-1800	1/2	7080	13878	9722	50	54	8	60	30	85#	12"
EEW20X28TR13D4	28	13	20-1800	1/2	7080	13878	9722	50	54	8	60	30	85#	12"
EEW20X37TR9D4	37	9	12-1800	1/2	7510	13978	9844	56	60	8	72	36	85#	12"
EEW20X37TR13D4	37	13	20-1800	1/2	7510	13978	9844	56	60	8	72	36	85#	12"
EEW20X53TR9D4	53	9	12-1800	1/2	8290	14155	10062	67	70	9-1/2	96	48	85#	12"
EEW20X53TR13D4	53	13	20-1800	1/2	8290	14155	10062	67	70	9-1/2	96	48	85#	12"

TR Trolley Speeds 60 fpm - 1½ hp 1800 rpm
 70 fpm - 2 hp 1800 rpm
 90 fpm - 3 hp 1800 rpm

Additional lifts, speeds and non-rotating rope available, consult factory.
Yale reserves the right to make product changes as necessary.

4 Part Double Reeving

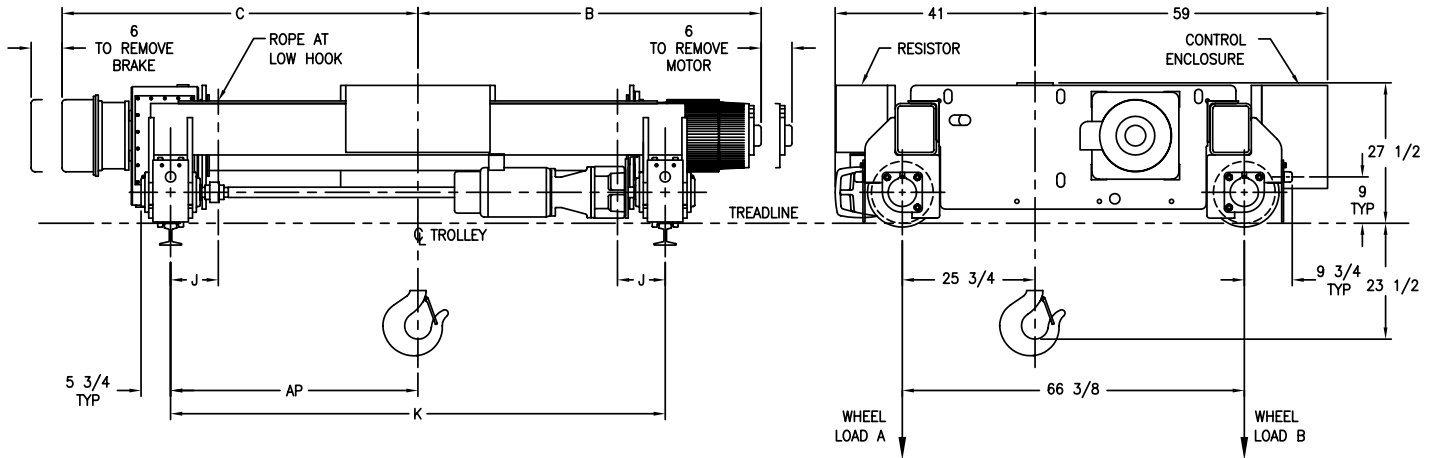

Drawing 23484421

Model Number	Lift (ft)	Speed fpm	Motor HP/RPM	Rope Dia.	Est Net Weight	WLA	WLB	B	C	J	K Gage Std.	AP (Gage/2)	Max Rail Size (ASCE)	Wheel Tread Dia.
EEW20X22TR21D4	22	21	30-1800	1/2	7070	13861	9721	59	49	6-1/2	48	24	85#	12"
EEW20X28TR21D4	28	21	30-1800	1/2	7380	13938	9812	64	54	8	60	30	85#	12"
EEW20X37TR21D4	37	21	30-1800	1/2	7810	14037	9934	70	60	8	72	36	85#	12"
EEW20X53TR21D4	53	21	30-1800	1/2	8590	14215	10153	80	70	9-1/2	96	48	85#	12"

TR Trolley Speeds 60 fpm - 1½ hp 1800 rpm
 70 fpm - 2 hp 1800 rpm
 90 fpm - 3 hp 1800 rpm

Additional lifts, speeds and non-rotating rope available, consult factory.
Yale reserves the right to make product changes as necessary.

4 Part Double Reeving

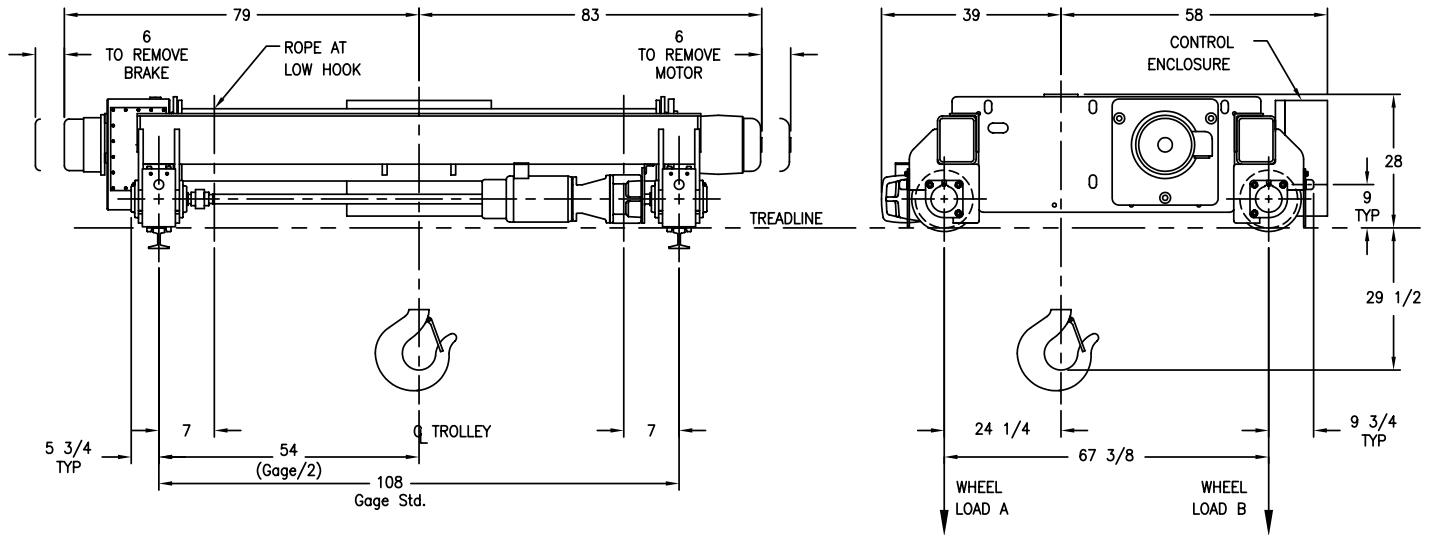

Drawing 23484422

Model Number	Lift (ft)	Speed fpm	Motor HP/RPM	Rope Dia.	Est Net Weight	WLA	WLB	Max Rail Size (ASCE)	Wheel Tread Dia.
FEW20-75TR14D4	75	14	20-1800	1/2	9280	14816	9899	85#	12"

TR Trolley Speeds
 60 fpm - 1½ hp 1800 rpm
 70 fpm - 2 hp 1800 rpm
 90 fpm - 3 hp 1800 rpm

Additional lifts, speeds and non-rotating rope available, consult factory.
Yale reserves the right to make product changes as necessary.

4 Part Double Reeving

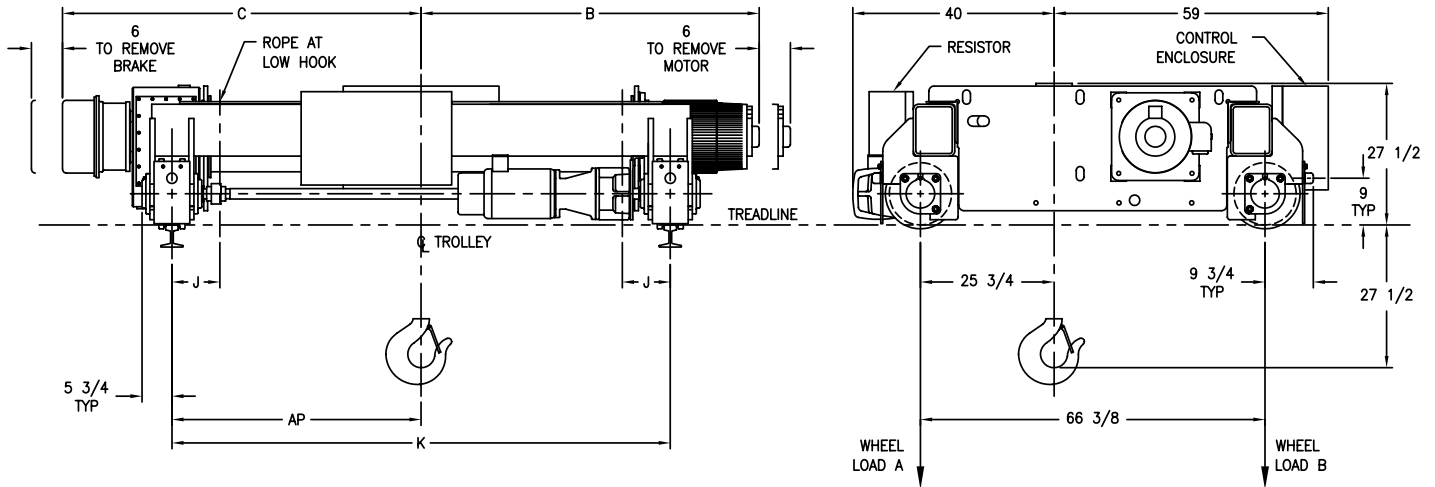

Drawing 23484423

Model Number	Lift (ft)	Speed fpm	Motor HP/RPM	Rope Dia.	Est Net Weight	WLA	WLB	B	C	J	K Gage Std.	AP (Gage/2)	Max Rail Size (ASCE)	Wheel Tread Dia.
EEW25X25TR9D4	25	9	20-1800	9/16	8010	17125	11941	50	54	8-3/8	60	30	85#	12"
EEW25X25TR13D4	25	13	25-1800	9/16	8010	17125	11941	51	54	8-3/8	60	30	85#	12"
EEW25X33TR9D4	33	9	20-1800	9/16	8630	17262	12120	56	60	8-3/8	72	36	85#	12"
EEW25X33TR13D4	33	13	25-1800	9/16	8630	17262	12120	57	60	8-3/8	72	36	85#	12"
EEW25X47TR13D4	47	13	25-1800	9/16	9720	17501	12431	67	70	9-7/8	96	48	85#	12"

TR Trolley Speeds
 60 fpm - 2 hp 1800 rpm
 70 fpm - 3 hp 1800 rpm
 90 fpm - 3 hp 1800 rpm

Additional lifts, speeds and non-rotating rope available, consult factory.
Yale reserves the right to make product changes as necessary.

4 Part Double Reeving

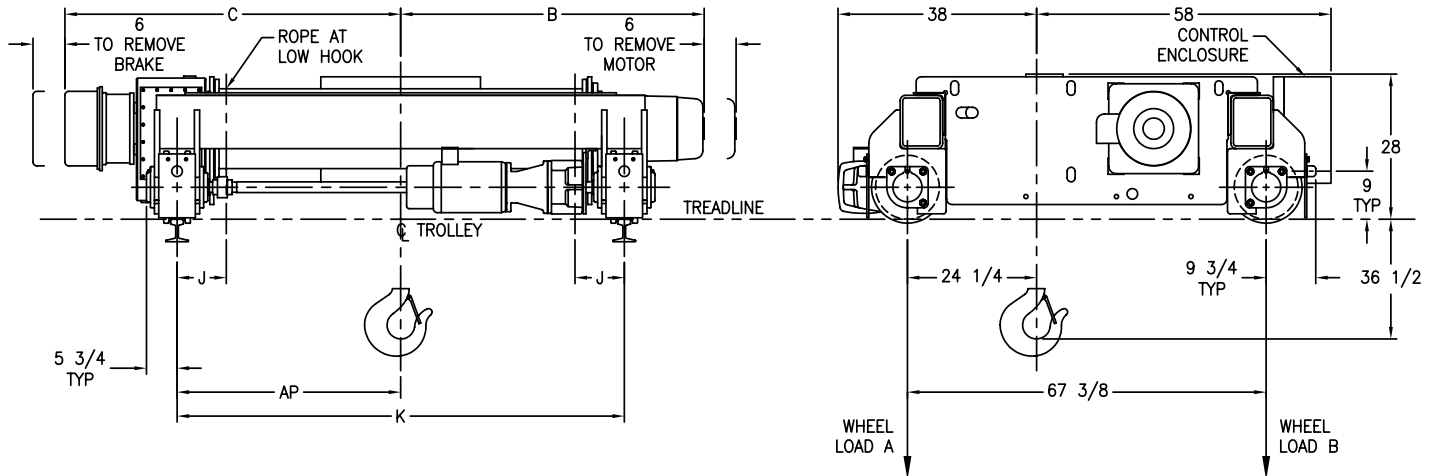

Drawing 23484424

Model Number	Lift (ft)	Speed fpm	Motor HP/RPM	Rope Dia.	Est Net Weight	WLA	WLB	B	C	J	K Gage Std.	AP (Gage/2)	Max Rail Size (ASCE)	Wheel Tread Dia.
FEW25-23TR7D4	23	7	15-1200	9/16	7000	17760	10750	49	49	7	48	24	85#	12"
FEW25-23TR11D4	23	11	20-1800	9/16	7000	17760	10750	49	49	7	48	24	85#	12"
FEW25-30TR7D4	30	7	15-1200	9/16	7400	17860	10850	55	55	8	60	30	85#	12"
FEW25-30TR11D4	30	11	20-1800	9/16	7400	17860	10850	55	55	8	60	30	85#	12"
FEW25-45TR7D4	45	7	15-1200	9/16	8200	18060	11050	65	65	10	84	42	85#	12"
FEW25-45TR11D4	45	11	20-1800	9/16	8200	18060	11050	65	65	10	84	42	85#	12"
FEW25-67TR7D4	67	7	15-1200	9/16	9200	18310	11300	79	79	7	108	54	85#	12"
FEW25-67TR11D4	67	11	20-1800	9/16	9200	18310	11300	79	79	7	108	54	85#	12"

TR Trolley Speeds 60 fpm - 2 hp 1800 rpm
 70 fpm - 3 hp 1800 rpm
 90 fpm - 3 hp 1800 rpm

Additional lifts, speeds and non-rotating rope available, consult factory.
Yale reserves the right to make product changes as necessary.

4 Part Double Reeving

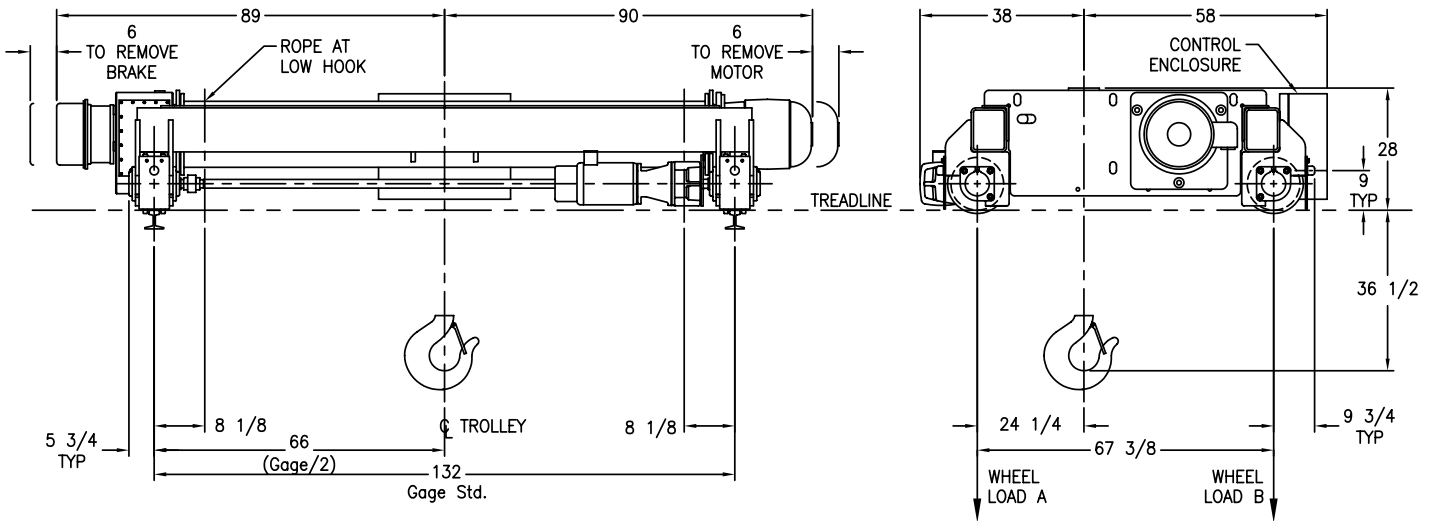

Drawing 23484425

Model Number	Lift (ft)	Speed fpm	Motor HP/RPM	Rope Dia.	Est Net Weight	WLA	WLB	Max Rail Size (ASCE)	Wheel Tread Dia.
FEW25-82TR12D4	82	12	20-1200	9/16	10990	18489	12088	85#	12"

TR Trolley Speeds
 60 fpm - 2 hp 1800 rpm
 70 fpm - 3 hp 1800 rpm
 90 fpm - 3 hp 1800 rpm

Additional lifts, speeds and non-rotating rope available, consult factory.
Yale reserves the right to make product changes as necessary.

6 Part Double Reeving

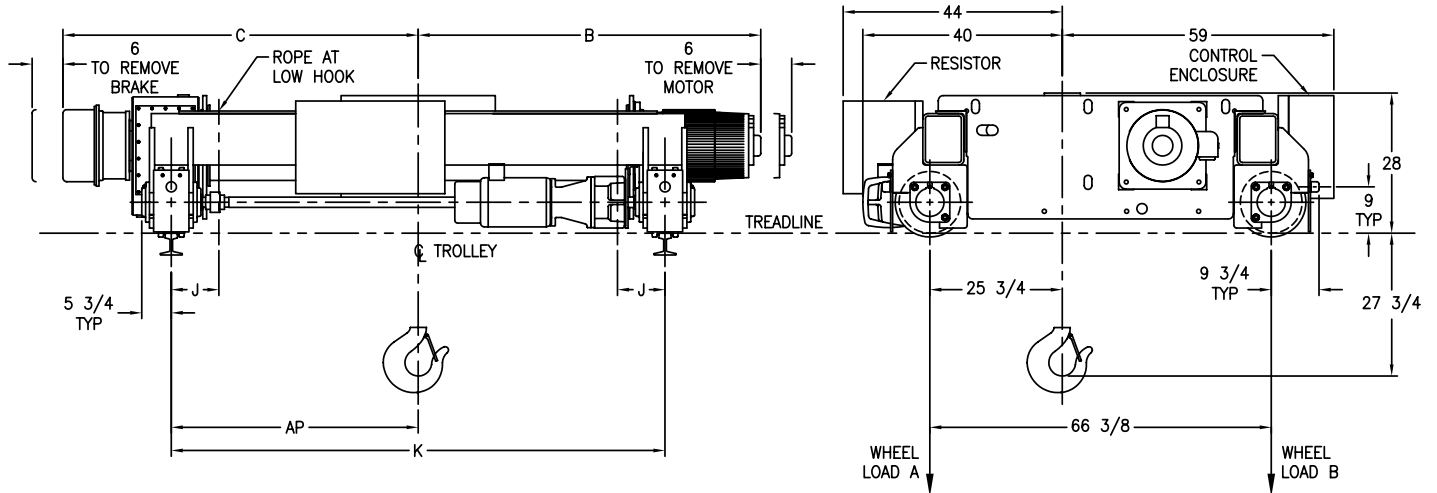

Drawing 23484426

Model Number	Lift (ft)	Speed fpm	Motor HP/RPM	Rope Dia.	Est Net Weight	WLA	WLB	B	C	J	K Gage Std.	AP (Gage/2)	Max Rail Size (ASCE)	Wheel Tread Dia.
EEW30X23TR8D6	23	8	20-1800	1/2	8370	20270	13981	60	61	8-1/4	72	36	85#	12"
EEW30X23TR10D6	23	10	25-1800	1/2	8370	20270	13981	65	61	8-1/4	72	36	85#	12"
EEW30X23TR14D6	23	14	30-1800	1/2	8370	20270	13981	65	61	8-1/4	72	36	85#	12"
EEW30X33TR8D6	33	8	20-1800	1/2	9120	20442	14191	70	71	9-3/4	96	48	85#	12"
EEW30X33TR10D6	33	10	25-1800	1/2	9120	20442	14191	75	71	9-3/4	96	48	85#	12"
EEW30X33TR14D6	33	14	30-1800	1/2	9120	20442	14191	75	71	9-3/4	96	48	85#	12"

TR Trolley Speeds 60 fpm - 2 hp 1800 rpm
70 fpm - 3 hp 1800 rpm
90 fpm - 3 hp 1800 rpm

Additional lifts, speeds and non-rotating rope available, consult factory.
Yale reserves the right to make product changes as necessary.

6 Part Double Reeving

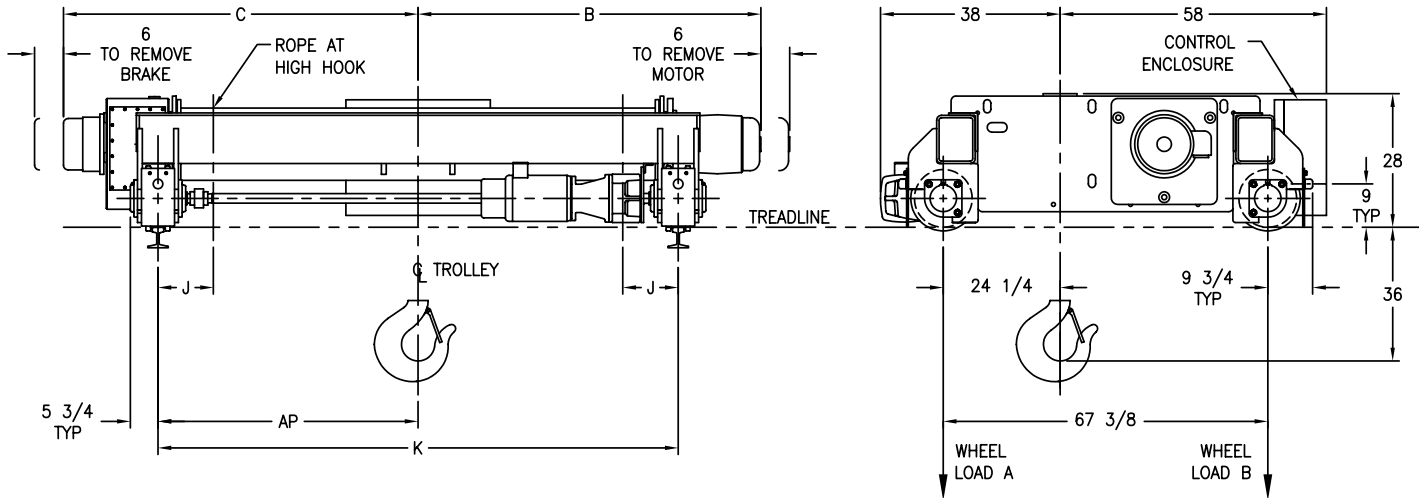

Drawing 23484427

Model Number	Lift (ft)	Speed fpm	Motor HP/RPM	Rope Dia.	Est Net Weight	WLA	WLB	B	C	J	K Gage Std.	AP (Gage/2)	Max Rail Size (ASCE)	Wheel Tread Dia.
FEW30-20TR7D6	20	7	15-1800	1/2	8000	21210	12800	56	56	7-1/2	60	30	85#	12"
FEW30-20TR10D6	20	10	20-1800	1/2	8000	21210	12800	56	56	7-1/2	60	30	85#	12"
FEW30-31TR7D6	31	7	15-1800	1/2	8700	21380	12980	66	66	9-1/2	84	42	85#	12"
FEW30-31TR10D6	31	10	20-1800	1/2	8700	21380	12980	66	66	9-1/2	84	42	85#	12"
FEW30-47TR7D6	47	7	15-1800	1/2	9700	21630	13230	79	79	6-1/2	108	54	85#	12"
FEW30-47TR10D6	47	10	20-1800	1/2	9700	21630	13230	79	79	6-1/2	108	54	85#	12"
FEW30-58TR10D6	58	10	20-1200	1/2	11320	21755	13987	89	89	8-1/2	132	66	85#	12"

TR Trolley Speeds
 60 fpm - 2 hp 1800 rpm
 70 fpm - 3 hp 1800 rpm
 90 fpm - 3 hp 1800 rpm

Additional lifts, speeds and non-rotating rope available, consult factory.
Yale reserves the right to make product changes as necessary.

6 Part Double Reeving

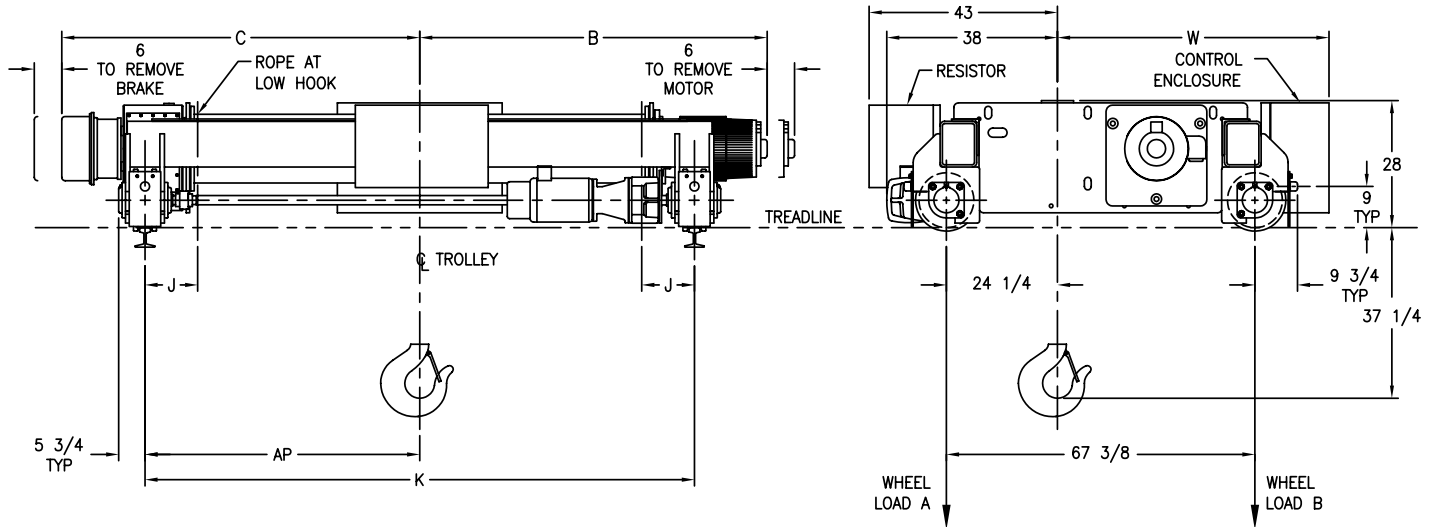

Drawing 23484428

Model Number	Lift (ft)	Speed fpm	Motor HP/RPM	Rope Dia.	Est Net Weight	WLA	WLB	B	C	J	K Gage Std.	AP (Gage/2)	W	Max Rail Size (ASCE)	Wheel Tread Dia.
FEW35-28TR7D6	28	7	20-1800	9/16	9640	24577	15313	66	66	9-1/2	84	42	58	85#	12"
FEW35-28TR12D6	28	12	30-1800	9/16	9640	24577	15313	75	66	9-1/2	84	42	62	85#	12"
FEW35-42TR7D6	42	7	20-1800	9/16	10930	24857	15684	79	79	6-1/2	108	54	58	85#	12"
FEW35-42TR12D6	42	12	30-1800	9/16	10930	24857	15684	90	79	6-1/2	108	54	62	85#	12"

TR Trolley Speeds 60 fpm - 3 hp 1800 rpm
 70 fpm - 3 hp 1800 rpm
 90 fpm - 4 hp 1800 rpm

Additional lifts, speeds and non-rotating rope available, consult factory.

Yale reserves the right to make product changes as necessary.