



YALE·LIFT-TECH™

Crane Kits

*1/4 - 5 Ton Capacity
Spans to 48 feet*

Specifications

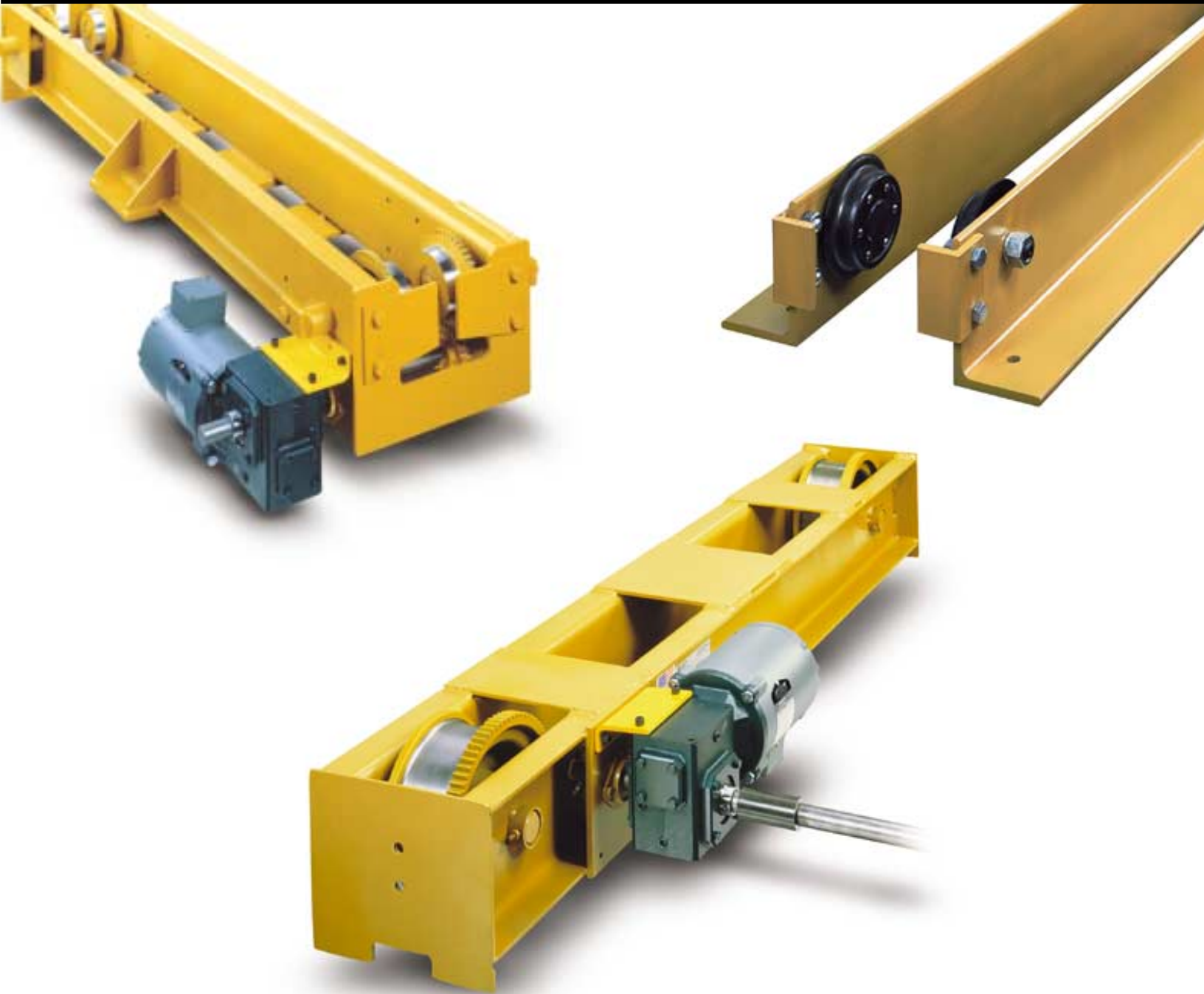

This Yale•Lift-Tech bulletin contains specifications and clearances for single girder crane kits with spans to 48' and capacities to 5 ton. These bridge kits are available in a wide variety to meet the exact requirements of your crane application.

Index

Subject	Page No.
Underhung	
Push Type Kits	3-5
Hand Geared Kits	6-7
Motor Driven Kits	8-13
Top Running	
Push and Hand Geared Kits	14-16
Motor Driven Kits	17-22
General Information	23-24

Capacity 1/2 - 5 tons/Spans to 36 feet

These Crane bridge kits contain all the parts needed to build underhung single girder crane bridges, except the bridge beam, cross shaft and trolley stop angles. An illustrated, easy-to-understand assembly manual is included in each kit.

Push type kits contain:

Each kit includes one pair of end trucks and the required hardware for attaching truck frames to bridge I-Beam.

Material to be Purchased Locally:

- One length of American Standard Section I-Beam or wide flange which must be a minimum length of 16 inches longer than the span for 3-ton bridge and 18-1/2 inches longer than the span for 5-ton bridge. See chart on page 5 to select proper beam size and the charts on page 4 for outline dimensions.
- Four trolley stop angles must be cut to size and attached to bridge beam.

Push Type Underhung Crane Kits

Maximum Capacity (tons)	Maximum Span (ft)	Kit Code	Runway Beam Flange Adj. Range	Wheel Type	Wheel Size (in)	Max. Wheel Load Per Pair (lbs)	Approximate Shipping Wt. (lbs)
Angle Construction Trucks							
1/2	30	905360	3" - 8"	Pressed Steel Wheels	4	1444	300
1	24	905360		Spark Resistant Wheels			
2	30	905361	3-3/8" - 8"	Pressed Steel Wheels	5	2730	310
		905362		Forged Steel Wheels	4		320
		905362PT	3-1/4"	Patented Track Wheels			
		905362SR	3-3/8" - 8"	Spark Resistant Wheels			
Channel Construction Trucks							
3	36	905368	3-3/8" - 5-1/2"	Forged Steel Wheels	4	4240	380
		905368W1	5-1/2" - 8"				390
		905368W2	8" - 10-1/2"				400
		905368SR	3-3/8" - 5-1/2"	Spark Resistant Wheels			380
		905368PT	3-1/4"	Patented Track Wheels			
	24	905368S	3-3/8" - 5-1/2"	3' - 0" Short Wheelbase			330
5	36	905524	4" - 6-1/4"	Forged Steel Wheels	6-1/2	7520	550
		905524W1	6-3/8" - 9"				560
		905524W2	9" - 11-1/2"				570
		905524PT	3-1/4"	Patented Track Wheels			550
		905524SR		Spark Resistant Wheels			
	24	905524S	4" - 6-1/4"	3' - 0" Short Wheelbase			495

**Push type bridges with
angle end trucks**
Catalog 905360, 905361 and
905362

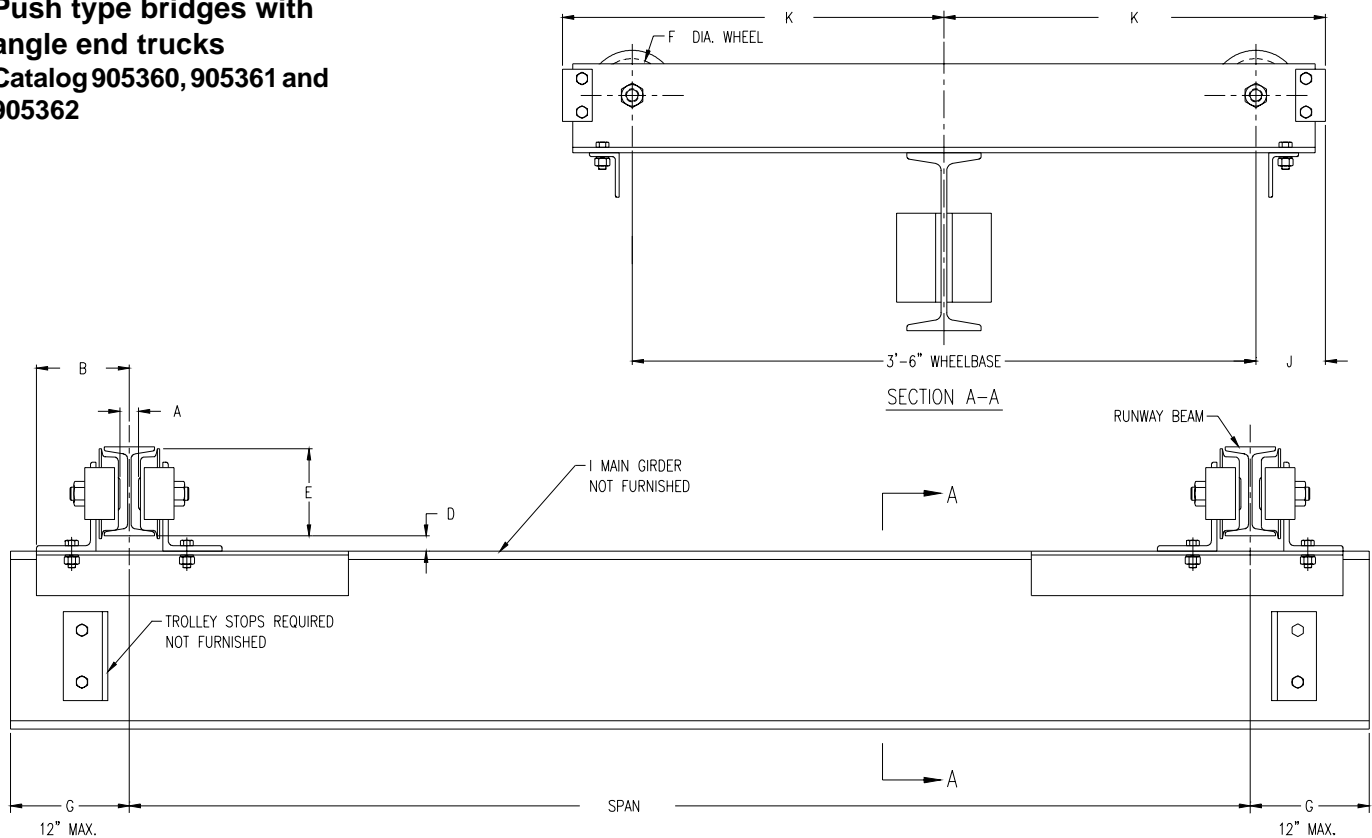

**Push type bridges with
channel end trucks**
Catalog 905368 and 905524

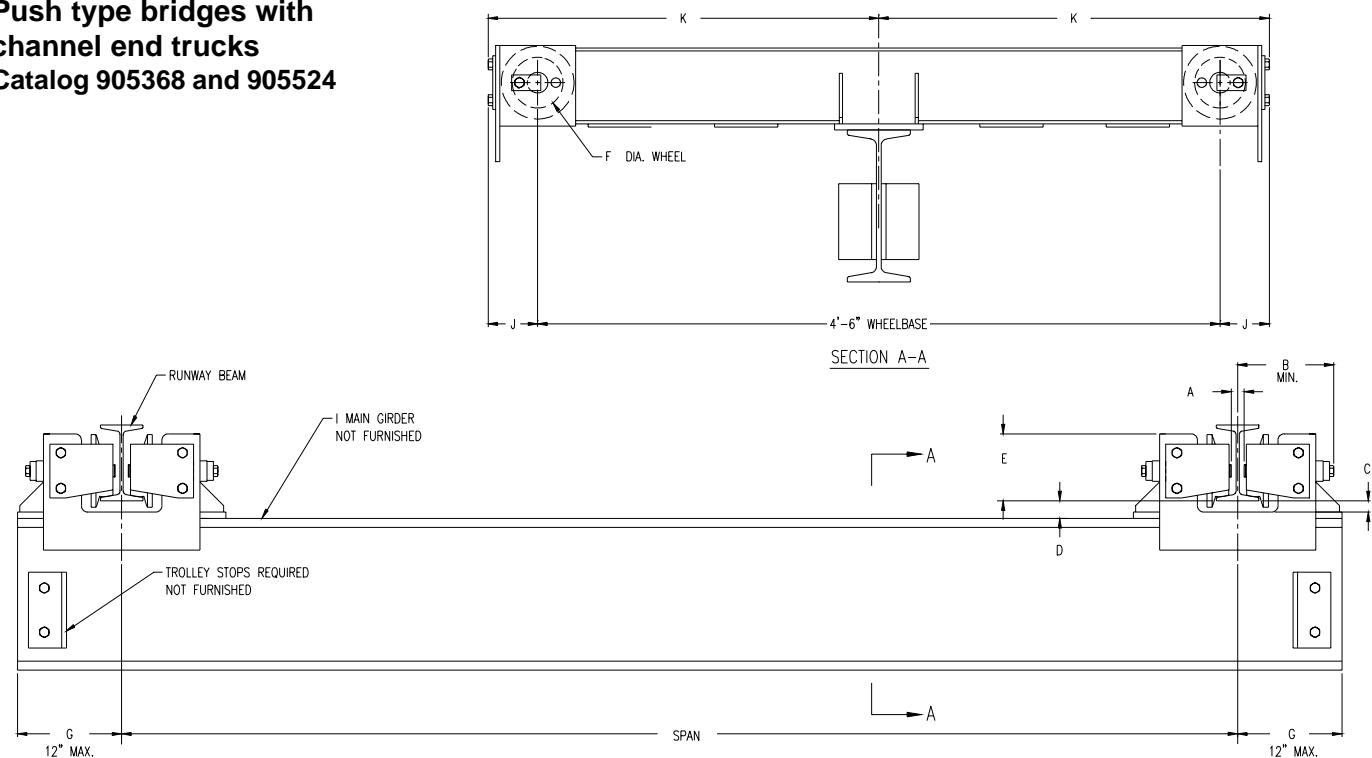

Dimension C = Dimension D Minus 1/2 inch

Bridge Girder Beam Sizes For - Push or Hand Geared Crane**

For Spans to (ft)	Rated Capacity* (tons)							
	1/4	1/2	1	1-1/2	2	3	4	5
10	S6x12.5	S7x15.3	S7x15.3	S8x18.4	S10x25.4	S12x40.8	S12x40.8	S12x40.8
12	S6x12.5	S7x15.3	S7x15.3	S10x25.4	S10x25.4	S12x40.8	S12x40.8	S18x54.7
14	S7x15.3	S7x15.3	S7x15.3	S10x25.4	S12x31.8	S12x40.8	S12x40.8	S18x54.7
16	S7x15.3	S7x15.3	S8x18.4	S10x25.4	S12x31.8	S12x40.8	S12x40.8	S18x54.7
18	S7x15.3	S7x15.3	S10x25.4	S10x25.4	S12x31.8	S12x40.8	S15x42.9	S18x54.7
20	S7x15.3	S8x18.4	S10x25.4	S12x31.8	S12x31.8	S12x40.8	S18x54.7	S18x54.7
22	S8x18.4	S10x25.4	S10x25.4	S12x31.8	S12x40.8	S18x54.7	S18x54.7	S20x66
24	S8x18.4	S10x25.4	S12x31.8	S12x40.8	S12x40.8	S18x54.7	S18x54.7	S20x66
26	S10x25.4	S10x25.4	S12x31.8	S12x40.8	S15x42.9	S18x54.7	S20x66	S24x80
28	S10x25.4	S10x25.4	S12x40.8	S12x40.8	S18x54.7	S20x66	S20x66	S24x80
30	S10x25.4	S12x31.8	S12x40.8	S18x54.7	S18x54.7	S20x66	S18x54.7C9x13.4	S24x80
32	S10x25.4	S12x31.8	S12x40.8	S18x54.7	S15x42.9C8x11.5	S18x54.7C9x13.4	S18x54.7C9x13.4	S20x66C9x13.4
34	S12x31.8	S12x40.8	S15x42.9	S18x54.7	S15x42.9C8x11.5	S18x54.7C9x13.4	S18x54.7C9x13.4	S20x66C9x13.4
36	S12x31.8	S12x40.8	S18x54.7	S15x42.9C8x11.5	S15x42.9C8x11.5	S18x54.7C9x13.4	S20x66C9x13.4	S20x66C9x13.4

* Rated capacity is based on maximum combined hoist and trolley weights of 500 pounds for 1/4, 1/2 and 1 ton hoists; 1100 pounds for 1 1/2 and 2 ton hoists; 1600 pounds for 3 and 4 ton hoists; 2000 pounds for 5 ton hoists. Bridge designed in accordance with CMAA Specification No. 74.

**Beam sizes listed are American Standard I-Beam and channel sections. Use ASTM A36 grade steel, first quality, free of rust and excessive mill scale.

Clearance Dimensions (in.) For Push Type Cranes

Product Code	Rated Capacity* (tons)	Max. Span (ft)	Runway Beam Sizes**			A	B	C	D	E	F Wheel Dia.	G Min.	H	J†	K
			Min. Beam Width	Min. Flange Width	Max. Flange Width										
Push Type Kit															
905360	1/2	30	S5x10	3	8	1-1/4	6-1/16	—	1-5/8	4-13/16	4	8	—	4-3/4	2' - 1-3/4"
	1	24				1-3/8	6-1/4		1-1/16	5-7/8	5				
905361	2	30	S6x12.5	3-3/8	8	1-1/4	6-11/16	—	1-9/16	5-13/16	4	8-1/4	—	—	—
905362						1-1/8	7-13/16		15/16	1-7/16					
905368	3	36	S8x18.4	4	5-1/2	1-1/8	7-13/16	15/16	1-7/16	5-1/8	4	8-1/4	14	4	2' - 7"
905524	5				6-1/4	3/4	8-11/16	13/16	1-5/16	8			6-1/2	9-3/8	14-5/8

**Runway beam sizes shown indicate range of beams that trucks will fit. For proper runway size, consult qualified engineer or architect.

End trucks for wider flange beams or 3-1/4" patented track are available.

Dimensions A, B, C, D and E are based on minimum beam.

† Dimension with rubber bumpers: 3 ton catalogs 905368 = 7 3/8 and 5 ton catalogs 905524 = 8-7/8.

Capacity 1/2 - 5 tons/Spans to 36 feet

These Crane bridge kits contain all the parts needed to build underhung single girder crane bridges, except the bridge beam, cross shaft and trolley stop angles. An illustrated, easy-to-understand assembly manual is included in each kit.

Hand geared kits contain:

- End trucks (1 pair) complete with driving pinion and attachment hardware
- Cross shaft support (quantity based upon span)
- Drive couplings (quantity based upon span)
- Chain wheel and chain guide
- 36 foot length of hand chain with open connecting link

Material to be Purchased Locally:

- One length of American Standard Section I-Beam or wide flange which must be a minimum length of 16 inches longer than the span for 3-ton bridge and 18-1/2 inches longer than the span for 5-ton bridge. See chart on page 5 to select proper beam size and the chart on page 7 for outline dimensions.
- Four trolley stop angles must be cut to size and attached to bridge beam.
- Hand Geared Bridges Only. One inch diameter cross shaft is required. Length depends on span and is determined by referring to outline dimensions on page 7.

Max. Capacity (tons)	Max. Span (ft)	Kit Code	End Truck Code Number	Kit Consists Of:				Wheel Size and Type	Max. Wheel Load per pair (lbs)	Approx. Shipping wt. (lbs)
				Cross Shaft Support Assembly		Cross Shaft Coupling				
				Qty.	Code Number	Qty.	Code Number			
Standard										
3	15	B03/15UHG	905369 4' - 6" WB	1	905373	2	905374	4" dia. geared solid forged steel wheels	4240	440
	22	B03/22UHG		2		2				442
	29	B03/29UHG		3		3				446
	36	B03/36UHG		4		3				448
5	15	B05/15UHG	905525 4' - 6" WB	1	905373	2	905374	6-1/2" dia. geared solid forged steel wheels	7520	520
	22	B05/22UHG		2		2				522
	29	B05/29UHG		3		3				526
	36	B05/36UHG		4		3				528
Spark Resistant										
3	15	B03/15UHGSR	905369SR 4' - 6" WB	1	905373	2	905374	4" dia. geared bronze wheels	4240	480
	22	B03/22UHGSR		2		2				482
	29	B03/29UHGSR		3		3				486
	36	B03/36UHGSR		4		3				488
5	15	B05/15UHGSR	905525SR 4' - 6" WB	1	905373	2	905374	6-1/2" dia. geared bronze wheels	7520	570
	22	B05/22UHGSR		2		2				572
	29	B05/29UHGSR		3		3				576
	36	B05/36UHGSR		4		3				578

Kit Consists of: 904550 Hand Chain Wheel
36' Hand Chain
1 Hand Chain Link

2 End Trucks
Cross Shaft Support as noted above
Cross Shaft Coupling as noted above

Shaft Diameter is 1"
For Runway Flange Widths of 3³/₈" - 5¹/₂" 3 ton
For Runway Flange Widths of 4" - 6¹/₄" 5 ton

Hand geared bridges with channel end trucks Catalog 905369 and 905525

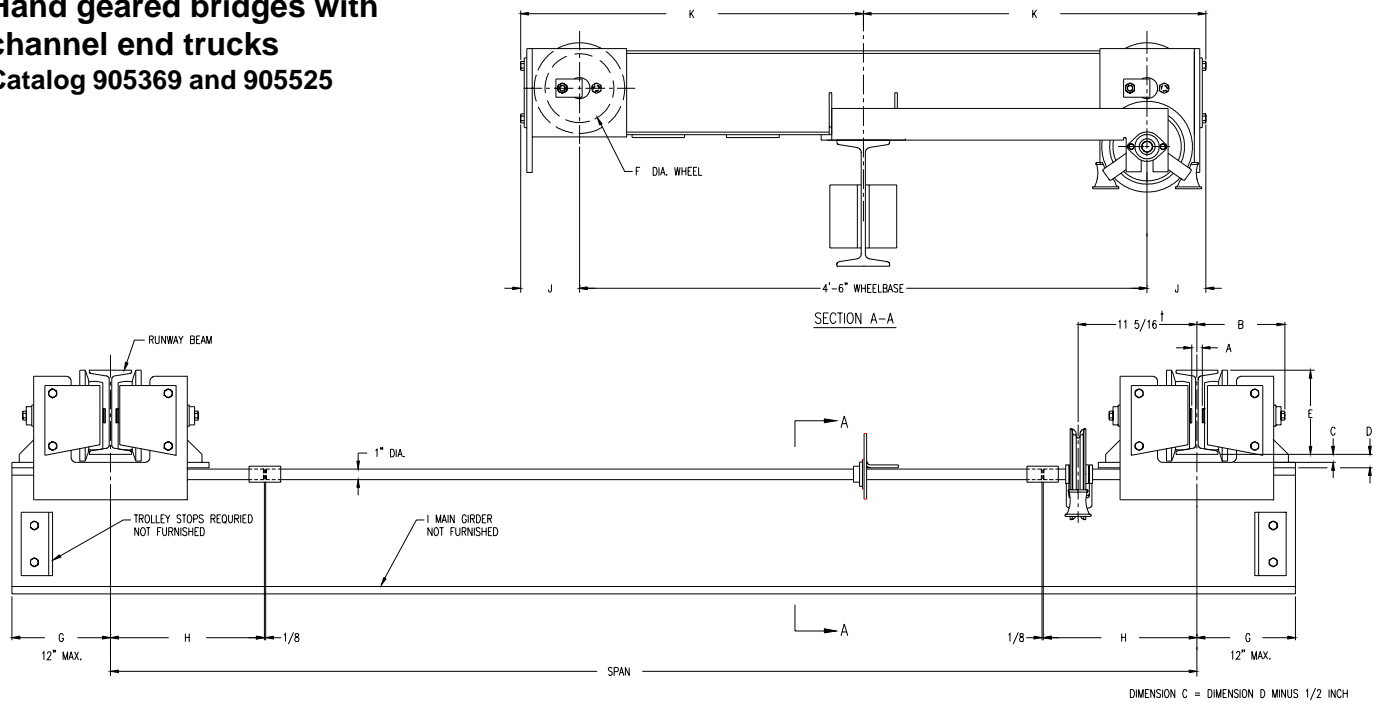

Clearance Dimensions (in.)

Product Code	Rated Capacity (tons)	Max. Span (ft)	Runway Beam Sizes**			A	B	C	D	E	F Wheel Dia.	G Min.	H	J†	K
			Min Beam Width	Min. Flange Width	Max. Flange Width										
Hand Geared Type End Trucks															
905369	3	36	S6x12.5	3-3/8	5-1/2	1-1/8	7-13/16	15/16	1-7/16	5-1/8	4	8-1/4	14	5-1/4	2' - 7"
905525	5		S8x18.4	4	6-1/4	3/4	8-11/16	13/16	1-5/16	8	6-1/2	9-3/8	14-5/8	5-1/2	2' - 8-5/8"

**Runway beam sizes shown indicate range of beams that trucks will fit. For proper runway size, consult qualified engineer or architect.

End trucks for wider flange beams or 3-1/4" patented track are available.

Dimensions A, B, C, D and E are based on minimum beam.

† Dimension with rubber bumpers: 3 ton catalogs 905369 = 7 3/8 and 5 ton catalogs 905525 = 8-7/8.

Motor Driven with Single Drive Capacity 1/4 to 3 ton/Spans to 36 feet

Max. Capacity (tons)	Max. span (ft)	Speed (fpm)	Kit Code 1 Speed	Kit Consists Of:					Approx Shipping (lbs)		
				End Trucks Code Number	Gear Reducer	Cross Shaft Support (Qty)	Cross Shaft Coupling (Qty)	Controls & Motors	1 Speed	2 Speed	
1/4 thru 3	8	55	B03/08UC*55	905369 4'-6" WB	905378	0			1 each Control	524	544
		70	B03/08UC*70		905377						
		110	B03/08UC*110		905376						
	15	55	B03/15UC*55		905378	1	2		1 each Control	544	564
		70	B03/15UC*70		905377						
		110	B03/15UC*110		905376						
	22	55	B03/22UC*55		905378	2			1 each ½ hp motor	564	584
		70	B03/22UC*70		905377						
		110	B03/22UC*110		905376						
	29	55	B03/29UC*55		905378	3			1 each Disconnect (see below)	586	606
		70	B03/29UC*70		905377						
		110	B03/29UC*110		905376						
	36	55	B03/36UC*55		905378	4	3			606	626
		70	B03/36UC*70		905377						
		110	B03/36UC*110		905376						

For runway flange width of 3-3/8" - 5-1/2"

Max wheel load per pair - 4240 lbs.

Wheels - 4" diameter solid forged steel

* **Specify:** 1 = Single Speed

2 = Two Speed

Motor and Controls for Single Drive Underhung Cranes

208 - 230 Volt			460 Volt			575 volt		
1/2 hp Motor (1) req'd	Control (1) req'd	Disconnect Switch (1) req'd	1/2 hp Motor (1) req'd	Control (1) req'd	Disconnect Switch (1) req'd	1/2 hp Motor (1) req'd	Control (1) req'd	Disconnect Switch (1) req'd
Single Speed								
905381	44600301	905388	905381	44600303	905389	905382	44600304	905389
Two Speed								
905394	44600341	905388	905395	44600343	905389	905396	44600344	905389

Single phase available

NEMA1 Enclosures Standard

Motor Driven with Single Drive Capacity 1/4 - 5 ton/Spans to 36 feet

Max. Capacity (tons)	Max. span (ft)	Speed (fpm)	Kit Code 1 Speed	Kit Consists Of:					Approx Shipping (lbs)	
				End Trucks Code Number	Gear Reducer	Cross Shaft Support (Qty)	Cross Shaft Coupling (Qty)	Controls & Motors	1 Speed	2 Speed
1/4 thru 5	8	50	B05/08UC*50	905525 4'-6" WB	905378	0		1 each Control 1 each ½ hp motor 1 each Disconnect (see below)	644	664
		65	B05/08UC*65		905377					
		100	B05/08UC*100		905376					
	15	50	B05/15UC*50		905378	1	2		664	684
		65	B05/15UC*65		905377					
		100	B05/15UC*100		905376					
	22	50	B05/22UC*50		905378	2			684	704
		65	B05/22UC*65		905377					
		100	B05/22UC*100		905376					
	29	50	B05/29UC*50		905378	3			704	724
		65	B05/29UC*65		905377					
		100	B05/29UC*100		905376					
	36	50	B05/36UC*50		905378	4	3		724	744
		65	B05/36UC*65		905377					
		100	B05/36UC*100		905376					

- For Runway Flange Widths of 4"-6¼"

***Specify:** 1=Single Speed Max wheel load per pair - 7520 lbs.
2=Two Speed Wheels - 6½" diameter solid forged steel

Motor and Controls for Single Drive Underhung Cranes

208 - 230 Volt			460 Volt			575 volt		
1/2 hp Motor (1) req'd	Control (1) req'd	Disconnect Switch (1) req'd	1/2 hp Motor (1) req'd	Control (1) req'd	Disconnect Switch (1) req'd	1/2 hp Motor (1) req'd	Control (1) req'd	Disconnect Switch (1) req'd
Single Speed								
905381	44600301	905388	905381	44600303	905389	905382	44600304	905389
Two Speed								
905394	44600341	905388	905395	44600343	905389	905396	44600344	905389

Single phase available

NEMA1 Enclosures Standard

Control panel includes mainline contactor, bridge fusing, reversing contactor and 115 volt control circuit transformer.

Motor Driven with Dual Drive Underhung

Capacity 1/4 - 3 ton/Spans to 48 feet

Max. Capacity (tons)	Max. Span (ft)	Speed (fpm)	Kit Code No.	Kit Consists of			Approximate Shipping Weight (lbs)	
				End Truck Code No.	Gear Reducer (Qty 2)	Controls & Motors	1 Speed	2 Speed
3	36	55	B03/36UD*55	905369 4' - 6" WB	905378	1 each Control 2 each 1/2 hp Motor 1 each Disconnect (See Below)	545	565
		70	B03/36UD*70		905377			
		110	B03/36UD*110		905376			
	48	55	Not Available					
		70	B03/48UD*70	905380	905377	1 each Control 2 each 1/2 hp Motor 1 each Disconnect (See Below)	645	665
		110	B03/48UD*100	6' - 0" WB	905376			

- For Runway Flange Widths of 3³/₈"-5¹/₂"
Single phase not available

* Specify: 1 = Single Speed
2 = Two Speed

Capacity 1/4 - 5 ton/Spans to 36 feet

Max. Capacity (tons)	Max. Span (ft)	Speed (fpm)	Kit Code	Kit Consists Of:			Approx Shipping wt (lbs)	
				End Truck Code Number	Gear Reducer (Qty 2)	Controls & Motors	1 Speed	2 Speed
Standard								
1/4 thru 5	36	50	B05/36UD*50	905525 4'-6" WB	905378	1 each Control 2 each 1/2 hp Motor 1 each Disconnect (see below)	665	685
		65	B05/36UD*65		905377			
		100	B05/36UD*100		905376			

- For Runway Flange Widths of 4"-6¹/₄"
Single phase not available

* Specify: 1 = Single Speed
2 = Two Speed

Motor & Controls for Dual Drive Underhung Cranes

Max. Span (ft)	Travel Speed (fpm)	Number of Speeds	200 - 208 Volt Power			230 Volt Power		
			Motor 2 Req'd	Control 1 Req'd	Disconnect Switch 1 Req'd	Motor 2 Req'd	Control 1 Req'd	Disconnect Switch 1 Req'd
36	50, 70 and 100	Single	1/2 HP 905381	44600311	905388	1/2 HP 905381	44600311	905388
		Two	1/2 HP 32879624	44600351	905388	1/2 HP 905394	44600351	905388
48	50	Not Available						
	70 and 100	Single	1/2 HP 905381	44600311	905388	1/2 HP 905381	44600311	905388
		Two	1/2 HP 32879624	44600351	905388	1/2 HP 905394	44600351	905388
			460 Volt Power			575 Volt Power		
36	50, 70 and 100	Single	1/2 HP 905381	44600313	905389	1/2 HP 905382	44600314	905389
		Two	1/2 HP 905395	44600343	905389	1/2 HP 905396	44600344	905389
48	50	Not Available						
	70 and 100	Single	1/2 HP 905381	44600313	905389	1/2 HP 905382	44600314	905389
		Two	1/2 HP 905395	44600343	905389	1/2 HP 905396	44600344	905389

Single phase not available

NEMA 1 Enclosures Standard

Control panel includes mainline contactor, bridge fusing, reversing contactor and 115 volt control circuit transformer.

Bridge Girder Beam Sizes For Various Spans - Motor Driven Crane American Standard Wide Flange Beams

BEAM SIZES FOR VARIOUS SPANS								
Spans To	(*) RATED LOAD IN TONS of 2000#							
	1/4	1/2	1	1-1/2	2	3	4	5
Push or Hand Geared Crane (54" Wheelbase)								
10 ft.	W 6x12	W 6x12	W 8x15	W 10x19	W 12x22	W 10x30	W 14x38	W 18x46
12 ft.	W 6x12	W 6x12	W 8x15	W 10x19	W 12x22	W 12x35	W 18x40	W 18x46
14 ft.	W 6x12	W 6x12	W 8x15	W 10x19	W 10x26	W 12x35	W 18x40	W 18x46
16 ft.	W 6x12	W 8x15	W 8x18	W 10x26	W 14x26	W 14x38	W 16x45	W 16x50
18 ft.	W 8x15	W 8x18	W 8x18	W 10x26	W 10x30	W 18x40	W 16x45	W 18x55
20 ft.	W 8x15	W 8x18	W 8x21	W 10x26	W 10x30	W 18x40	W 18x46	W 16x57
22 ft.	W 8x18	W 8x18	W 10x26	W 10x30	W 14x34	W 12x45	W 16x50	W 16x57
24 ft.	W 8x18	W 8x21	W 10x26	W 10x30	W 12x35	W 16x45	W 16x50	W 16x57
26 ft.	W 8x21	W 10x22	W 10x30	W 12x35	W 14x38	W 14x48	W 14x53	W 18x60
28 ft.	W 10x22	W 10x26	W 10x30	W 14x38	W 12x40	W 14x48	W 16x57	W 18x65
30 ft.	W 10x22	W 10x26	W 14x34	W 12x40	W 14x43	W 14x53	W 18x65	W 18x71
32 ft.	W 10x26	W 10x30	W 12x35	W 14x43	W 14x48	W 18x60	W 16x67	W 16x77
34 ft.	W 10x26	W 12x30	W 14x38	W 14x48	W 14x48	W 18x65	W 16x67	W 16x77
36 ft.	W 10x30	W 14x34	W 12x40	W 14x48	W 14x53	W 16x67	W 16x77	W 16x89
Motor Driven Crane (54" Wheelbase)								
10 ft.	W 6x12	W 6x12	W 8x15	W 10x19	W 12x22	W 12x35	W 18x40	W 18x46
12 ft.	W 6x12	W 6x12	W 8x15	W 10x19	W 10x26	W 12x35	W 18x40	W 18x46
14 ft.	W 6x12	W 6x12	W 8x18	W 10x26	W 14x26	W 14x38	W 10x45	W 16x50
16 ft.	W 6x12	W 8x15	W 8x18	W 10x26	W 10x30	W 18x40	W 16x45	W 14x53
18 ft.	W 8x15	W 8x18	W 8x21	W 10x26	W 10x30	W 18x40	W 18x46	W 16x57
20 ft.	W 8x18	W 8x18	W 8x21	W 10x30	W 10x30	W 10x45	W 12x50	W 16x57
22 ft.	W 8x18	W 8x21	W 10x26	W 10x30	W 12x35	W 16x45	W 16x50	W 16x57
24 ft.	W 8x18	W 8x21	W 10x26	W 14x34	W 14x38	W 14x48	W 14x53	W 18x65
26 ft.	W 8x21	W 10x26	W 10x30	W 12x35	W 12x40	W 12x50	W 16x57	W 18x65
28 ft.	W 10x22	W 10x26	W 10x33	W 12x40	W 12x40	W 14x53	W 18x65	W 18x71
30 ft.	W 10x26	W 10x30	W 12x35	W 12x40	W 12x45	W 14x53	W 16x67	W 14x74
32 ft.	W 10x26	W 10x30	W 14x38	W 12x45	W 14x48	W 14x61	W 16x67	W 16x77
34 ft.	W 10x30	W 14x34	W 12x40	W 14x48	W 14x53	W 16x67	W 16x67	W 16x89
36 ft.	W 10x30	W 12x35	W 12x40	W 14x53	W 14x61	W 16x67	W 16x77	W 16x89
Motor Driven Crane Dual Drive - (72" Wheelbase)								
38 ft.	W 12x35	W 12x40	W 14x48	W 14x61	W 16x67	W 16x77	—	—
40 ft.	W 12x40	W 12x45	W 14x53	W 16x67	W 16x67	W 16x89	—	—
42 ft.	W 12x40	W 14-x48	W 14x61	W 16x67	W 16x67	W 18x86	—	—
44 ft.	W 14x43	W 14x48	W 14x61	W 16x67	W 16x77	W 18x86	—	—
46 ft.	W 14x48	W 14x53	W 16x67	W 16x77	W 18x76	W 18x97	—	—
48 ft.	W 14x53	W 14x61	W 16x67	W 18x76	W 18x86	W 21x101	—	—

* Rated load is based on maximum combined hoist and trolley weights of: 500 pounds for 1/4, 1/2 and 1 ton hoists; 1100 pounds for 1½ and 2 ton hoists; 1600 pounds for 3 and 4 ton hoists; 2000 pounds for 5 ton hoists. Bridge designed in accordance with latest edition of CMAA Specification No. 74, using Lift-Tech trolleys.

Bridge Girder Selection Table "S" Beams (American Standard I-Beams and Channel Sections)

(**) BEAM SIZES FOR VARIOUS SPANS								
Spans To	(*) RATED LOAD IN TONS of 2000#							
	1/4	1/2	1	1-1/2	2	3	4	5
Motor Driven Crane (54" Wheelbase)								
10 ft.	S 6x12.5	S 6x12.5	S 6x12.5	S 10x25.4	S 10x25.4	S 12x40.8	S 12x40.8	S 12x40.8
12 ft.	S 6x12.5	S 6x12.5	S 7x15.3	S 10x25.4	S 12x31.8	S 12x40.8	S 12x40.8	S 18x54.7
14 ft.	S 6x12.5	S 6x12.5	S 7x15.3	S 10x25.4	S 12x31.8	S 12x40.8	S 12x40.8	S 18x54.7
16 ft.	S 6x12.5	S 7x15.3	S 8x18.4	S 10x25.4	S 12x31.8	S 12x40.8	S 18x54.7	S 18x54.7
18 ft.	S 7x15.3	S 8x18.4	S 10x25.4	S 12x31.8	S 12x31.8	S 18x54.7	S 18x54.7	S 20x66
20 ft.	S 7x15.3	S 8x18.4	S 10x25.4	S 12x31.8	S 12x40.8	S 18x54.7	S 18x54.7	S 20x66
22 ft.	S 8x18.4	S 10x25.4	S 12x31.8	S 12x40.8	S 12x40.8	S 18x54.7	S 20x66	S 20x66
24 ft.	S 10x25.4	S 10x25.4	S 12x31.8	S 12x40.8	S 18x54.7	S 20x66	S 20x66	S 24x80
26 ft.	S 10x25.4	S 10x25.4	S 12x40.8	S 18x54.7	S 18x54.7	S 20x66	S 18x54.7 w/C 9x13.4	S 24x80
28 ft.	S 10x25.4	S 12x31.8	S 12x40.8	S 18x54.7	S 12x40.8 w/C 8x11.5	S 18x54.7 w/C 9x13.4	S 18x54.7 w/C 9x13.4	S 20x66 w/C 9x13.4
30 ft.	S 10x25.4	S 12x31.8	S 12x40.8	S 18x54.7	S 12x40.8 w/C 8x11.5	S 18x54.7 w/C 9x13.4	S 18x54.7 w/C 9x13.4	S 20x66 w/C 9x13.4
32 ft.	S 12x31.8	S 12x40.8	S 18x54.7	S 12x40.8 w/C 8x11.5	S 15x42.9 w/C 8x11.5	S 18x54.7 w/C 9x13.4	S 18x54.7 w/C 10x15.3	S 20x66 w/C 9x13.4
34 ft.	S 12x40.8	S 12x40.8	S 18x54.7	S 15x42.9 w/C 8x11.5	S 15x42.9 w/C 8x11.5	S 18x54.7 w/C 9x13.4	S 20x66 w/C 9x13.4	S 20x66 w/C 9x13.4
36 ft.	S 12x40.8	S 12x40.8	S 12x31.8 w/C 9x13.4	S 15x42.9 w/C 8x11.5	S 15x42.9 w/C 8x11.5	S 18x54.7 w/C 12x20.7	S 20x66 w/C 9x13.4	S 20x66 w/C 12x20.7

* Rated load is based on maximum combined hoist and trolley weights of: 500 pounds for 1/4, 1/2 and 1 ton hoists; 1100 pounds for 1½ and 2 ton hoists; 1600 pounds for 3 and 4 ton hoists; 2000 pounds for 5 ton hoists. Bridge designed in accordance with latest edition of CMAA Specification No. 74, using Lift-Tech trolleys.

** Beam sizes listed are American Standard I-Beam and Channel sections. Use ASTM A36 grade steel, first quality, free of rust and excessive mill scale.

Dual Drive

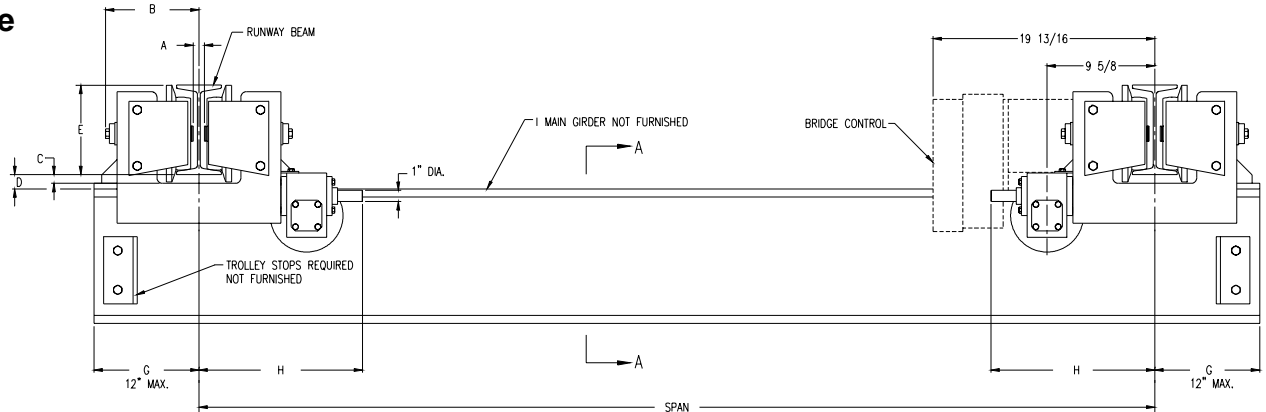

Single Drive

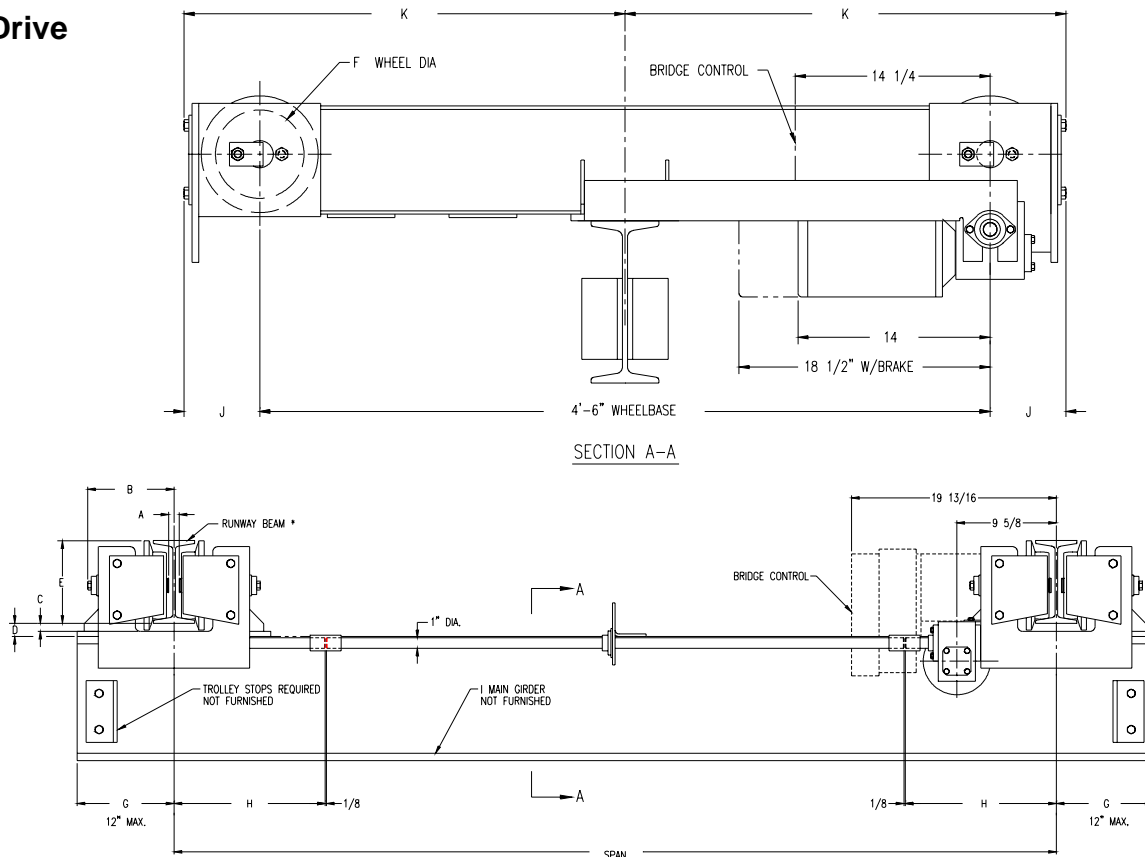

Clearance Dimensions (in.)

Product Code	Rated Capacity (tons)	* Max. Span (ft)	Runway Beam Sizes**			A	B	C	D	E	F Wheel Dia.	G Min.	H	J†	K	Max. Wheel Load Per Pair (lbs)	Approx. Shipping Wt (lbs)
			Min Beam Width	Min. Flange Width	Max. Flange Width												
905369	1/4 - 3	36	S6x12.5	3-3/8	5-1/2	1-1/8	7-13/16	15/16	1-7/16	5-1/8	4	8-1/4	14	4	2' - 7"	4240	400
905525	5	36	S8x18.4	4	6-1/4	3/4	8-11/16	13/16	1-5/16	8	6-1/2	9-3/8	14-5/8	5-1/2	2' - 8-5/8"	7520	480

**Runway beam sizes shown indicate range of beams that trucks will fit. For proper runway size, consult qualified engineer or architect.
End trucks for wider flange beams or 3-1/4" patented track are available.

Dimensions A, B, C, D and E are based on minimum beam.

† Dimension with rubber bumpers: 3 ton catalogs 905369 = 7 3/8 and 5 ton catalogs 905525 = 8-7/8.

* For spans from 36' up to 48' consult factory.

Push & Hand Geared Type Kits

Capacity 1/2 - 5 tons/Spans to 36 feet

Crane bridge kits contain all the parts needed to build top running single girder crane bridges, except for the bridge beam, cross shaft (when required) and trolley stop angles.

Push type kits contain:

- End trucks (1 pair)
- Complete attachment hardware



Hand geared kits contain:

- End trucks (1 pair) complete with driving pinion and attachment hardware
- Cross shaft support (quantity based upon span)
- Drive couplings (quantity based upon span)
- Chain wheel and chain guide
- 36 foot length of hand chain with open connecting link

Material to be purchased locally:

- American standard section I-beam or wide flange that is at least 9 1/4" longer than the bridge span
- Four trolley stop angles must be cut to size and attached to bridge beam
- For hand geared bridges only: 1" diameter cross shaft to match span. Please refer to dimension chart on page 16

Push Type Top Running Kits

Kit Code	Maximum Capacity (tons)	Maximum Span (ft)	Description	Maximum Wheel Load Per Pair (lbs)	Approximate Shipping Wt. (lbs)
904535	5	36	8" Ductile Iron Wheels 4'-6" WB	6500	450
904535SR			8" Spark Resistant Wheels 4'-6" WB		
904535S		24	8" Ductile Iron Wheels 3'-0" Short Wheel Base		405

Each kit includes one pair of end trucks and the required hardware to attach truck frames to bridge I-beam.

Hand Geared Top Running Capacity 1/4 - 5 tons/Spans to 36 feet

Max. Capacity (tons)	Max. Span (ft)	Kit Code	End Truck Code Number	Kit Consists Of:				Approx. Shipping wt. (lbs)	Wheel Size and Type	Max. Wheel Load per pair (lbs)
				Cross Shaft Bearing Assembly		Cross Shaft Coupling				
				Qty.	Code Number	Qty.	Code Number			
Standard										
1/4 thru 5	15	B05/15TH	904536 4' - 6" WB	1	904540	2	905374	500	8" dia. geared ductile iron	6500
	22	B05/22TH		2		2		515		
	29	B05/29TH		3		3		532		
	36	B05/36TH		4		3		549		
Spark Resistant										
1/4 thru 5	15	B05/15THSR	904536SR 4' - 6" WB	1	904540	2	905374	550	8" dia. geared bronze	6500
	22	B05/22THSR		2		2		565		
	29	B05/29THSR		3		3		582		
	36	B05/36THSR		4		3		599		

Kit Consists of: 904550 Hand Chain Wheel
36' Hand Chain
1 Hand Chain Link

2 End Trucks
Cross Shaft Bearing as noted above
Cross Shaft Coupling as noted above

Shaft Diameter is 1"

Bridge Girder Beam Sizes For Push or Hand Geared Cranes**

For Spans to (ft)	Rated Capacity* (tons)							
	1/4	1/2	1	1-1/2	2	3	4	5
10	S6x12.5	S7x15.3	S7x15.3	S8x18.4	S10x25.4	S12x40.8	S12x40.8	S12x40.8
12	S6x12.5	S7x15.3	S7x15.3	S10x25.4	S10x25.4	S12x40.8	S12x40.8	S18x54.7
14	S7x15.3	S7x15.3	S7x15.3	S10x25.4	S12x31.8	S12x40.8	S12x40.8	S18x54.7
16	S7x15.3	S7x15.3	S8x18.4	S10x25.4	S12x31.8	S12x40.8	S12x40.8	S18x54.7
18	S7x15.3	S7x15.3	S10x25.4	S10x25.4	S12x31.8	S12x40.8	S15x42.9	S18x54.7
20	S7x15.3	S8x18.4	S10x25.4	S12x31.8	S12x31.8	S12x40.8	S18x54.7	S18x54.7
22	S8x18.4	S10x25.4	S10x25.4	S12x31.8	S12x40.8	S18x54.7	S18x54.7	S20x66
24	S8x18.4	S10x25.4	S12x31.8	S12x40.8	S12x40.8	S18x54.7	S18x54.7	S20x66
26	S10x25.4	S10x25.4	S12x31.8	S12x40.8	S15x42.9	S18x54.7	S20x66	S24x80
28	S10x25.4	S10x25.4	S12x40.8	S12x40.8	S18x54.7	S20x66	S20x66	S24x80
30	S10x25.4	S12x31.8	S12x40.8	S18x54.7	S18x54.7	S20x66	S18x54.7C9x13.4	S24x80
32	S10x25.4	S12x31.8	S12x40.8	S18x54.7	S15x42.9C8x11.5	S18x54.7C9x13.4	S18x54.7C9x13.4	S20x66C9x13.4
34	S12x31.8	S12x40.8	S15x42.9	S18x54.7	S15x42.9C8x11.5	S18x54.7C9x13.4	S18x54.7C9x13.4	S20x66C9x13.4
36	S12x31.8	S12x40.8	S18x54.7	S15x42.9C8x11.5	S15x42.9C8x11.5	S18x54.7C9x13.4	S20x66C9x13.4	S20x66C9x13.4

* Rated capacity is based on maximum combined hoist and trolley weights of 500 pounds for 1/4, 1/2 and 1 ton hoists; 1100 pounds for 1 1/2 and 2 ton hoists; 1600 pounds for 3 and 4 ton hoists; 2000 pounds for 5 ton hoists. Bridge designed in accordance with CMAA Specification No. 74.

**Beam sizes listed are American standard I-Beam and channel sections. Use ASTM A36 grade steel, first quality, free of rust and excessive mill scale.

Outline Dimensions

Push Type

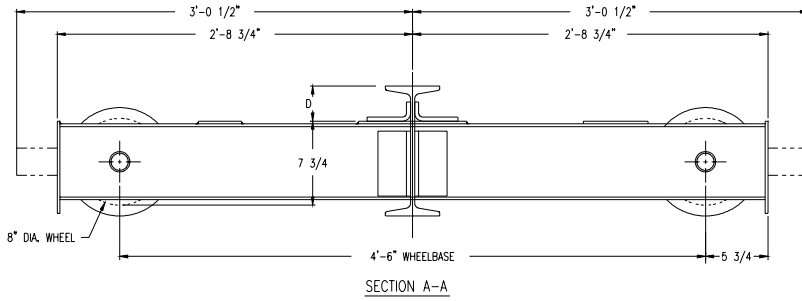

Beams (Depth)	D
6", 7", 8", 10" & 12"	3-1/4"
15", 18" & 20"	4-3/4"

$$J = 7\text{-}3/4" + D + 3"$$

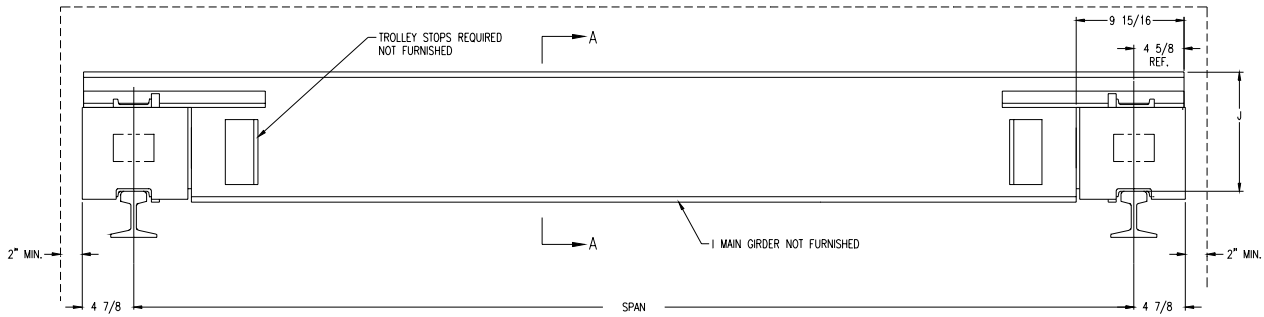

Hand Geared

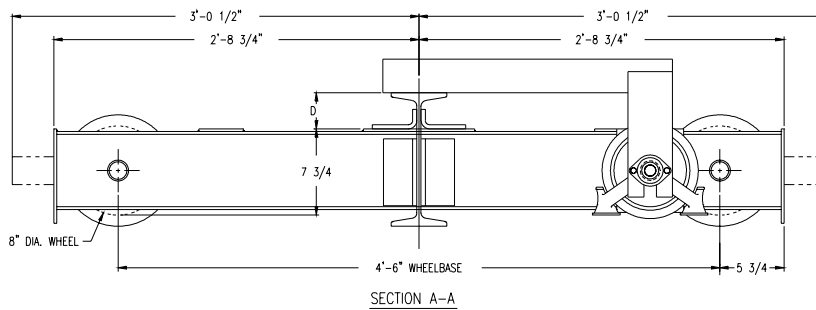

Beams (Depth)	D
6", 7", 8", 10" & 12"	3-1/4"
15", 18" & 20"	4-3/4"

$$J = 7\text{-}3/4" + D + 3"$$

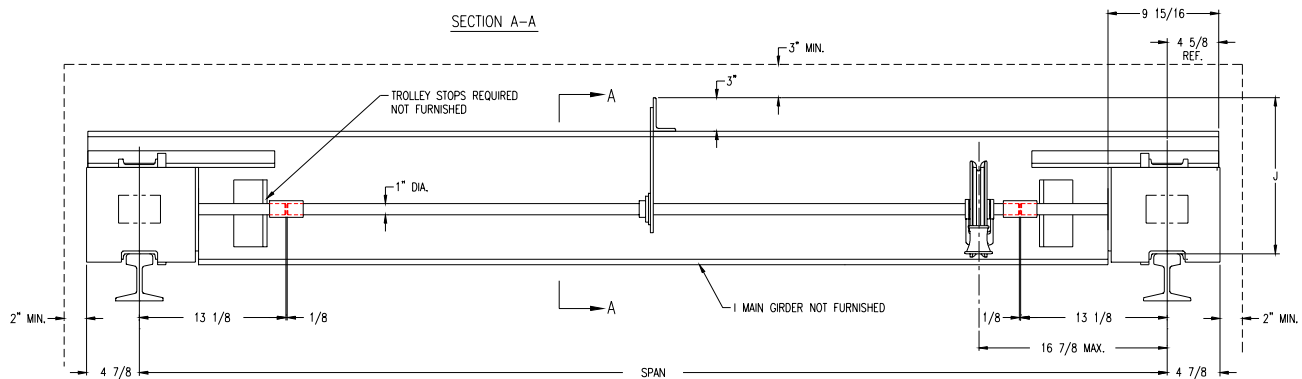

Motor Driven with Single Drive Capacity 1/4 - 5 ton/Spans to 36 feet

Max. Capacity (tons)	Max. Span (ft)	Speed (fpm)	Kit Code	Kit Consists Of:					Approx. Shipping wt (lbs)	
				End Truck Code Number	Gear Reducer	Cross Shaft Support (Qty)	Cross Shaft Coupling (Qty)	Controls & Motors	1 Speed	2 Speed
Standard										
1/4 thru 5	8	50	B05/08TC*50	904536 4'-6" WB	905378	0	2	1 each Control 1 each ½ hp Motor 1 each Disconnect (see below)	529	554
		70	B05/08TC*70		905377					
		100	B05/08TC*100		905376					
	15	50	B05/15TC*50		905378	1				
		70	B05/15TC*70		905377					
		100	B05/15TC*100		905376					
	22	50	B05/22TC*50		905378	2				
		70	B05/22TC*70		905377					
		100	B05/22TC*100		905376					
	29	50	B05/29TC*50		905378	3				
		70	B05/29TC*70		905377					
		100	B05/29TC*100		905376					
	36	50	B05/36TC*50		905378	4				
		70	B05/36TC*70		905377					
		100	B05/36TC*100		905376					

*Specify: 1=Single Speed
2=Two Speed

Motor & Controls for Single Drive Top Running Cranes

208 - 230 Volt			460 Volt			575 volt		
1/2 hp Motor (1) req'd	Control (1) req'd	Disconnect Switch (1) req'd	1/2 hp Motor (1) req'd	Control (1) req'd	Disconnect Switch (1) req'd	1/2 hp Motor (1) req'd	Control (1) req'd	Disconnect Switch (1) req'd
Single Speed								
905381	44600381	905388	905381	44600383	905389	905382	44600384	905389
Two Speed								
905394	44600391	905388	905395	44600393	905389	905396	44600394	905389

Single Phase Available
NEMA 1 Enclosures Standard
Control panel includes mainline contactor, bridge fusing, reversing contactor and 115 volt control circuit transformer.

Motor Driven with Dual Drive Capacity 1/4 to 5 ton/Spans to 48 feet

Max. Capacity (tons)	Max. Span (ft)	Speed (fpm)	Rail Size (# / yd)	Kit Consists of				Approximate Shipping Weight (lbs)	
				Kit Code Number	End Truck Code Number	Gear Reducer (Qty. 2)	Controls & Motor	1 Speed	2 Speed
5	36	50	25 to 40	B05/36TD*50	904536 4' - 6" WB	905378	1 each Control 2 each 1/2 hp Motor 1 each Disconnect (See Page 19)	575	615
		70		B05/36TD*70		905377			
		100		B05/36TD*100		905376			
	48	40	50	Not Available				675	715
			70	B05/48TD*70	904549	905377	1 each Control 2 each 3/4 hp Motor 1 each Disconnect (See Page 19)		
			100	B05/48TD*100	6' - 0" WB	905376			

*Specify: 1=Single Speed
2=Two Speed



**Top Running
Single Drive Kit**



**Top Running
Dual Drive Kit**

Motor & Controls for Dual Drive Top Running Cranes

Max. Span (ft)	Travel Speed (fpm)	No. of Speeds	200 - 208 Volt Power			230 Volt Power		
			Motor 2 Req'd	Control 1 Req'd	Disconnect Switch 1 Req'd	Motor 2 Req'd	Control 1 Req'd	Disconnect Switch 1 Req'd
36	50, 70 and 100	Single	1/2 hp 905381	44600326	905388	1/2 hp 905381	44600326	905388
		Two	1/2 hp 32879624	44600336	905388	1/2 hp 905394	44600336	905388
48	50	–	Not Available			Not Available		
	70	Single	1/2 hp 905381	44600326	905388	1/2 hp 905381	44600326	905388
		Two	1/2 hp 32879624	44600336	905388	1/2 hp 905394	44600336	905388
	100	Single	3/4 hp 32879542	44600329	905388	3/4 hp 32879542	44600329	905388
		Two	3/4 hp 32879643	44600339	905388	3/4 hp 32879635	44600339	905388

Max. Span (ft)	Travel Speed (fpm)	No. of Speeds	460 Volt Power			575 Volt Power		
			Motor 2 Req'd	Control 1 Req'd	Disconnect Switch 1 Req'd	Motor 2 Req'd	Control 1 Req'd	Disconnect Switch 1 Req'd
36	50, 70 and 100	Single	1/2 hp 905381	44600383	905389	1/2 hp 905382	44600384	905389
		Two	1/2 hp 905395	44600393	905389	1/2 hp 905396	44600394	905389
48	50	–	Not Available			Not Available		
	70	Single	1/2 hp 905381	44600383	905389	1/2 hp 905382	44600384	905389
		Two	1/2 hp 905395	44600393	905389	1/2 hp 905396	44600394	905389
	100	Single	3/4 hp 32879542	44600327	905389	3/4 hp 32879543	44600328	905389
		Two	3/4 hp 32879636	44600337	905389	3/4 hp 32879637	44600338	905389

Single Phase Not Available

NEMA 1 Enclosures Standard

Control panel includes mainline contactor, bridge fusing, reversing contactor and 115 volt control circuit transformer.

Bridge Girder Beam Sizes For Top Running Motor Driven Cranes American Standard I-Beams and Channel Selections

(**) BEAM SIZES FOR VARIOUS SPANS								
Spans To	(*) RATED LOAD IN TONS OF 2000#							
	1/4	1/2	1	1-1/2	2	3	4	5
Motor Driven Crane - 54" Wheelbase								
10 ft.	S 6x12.5	S 6x12.5	S 6x12.5	S 10x25.4	S 10x25.4	S 12x40.8	S 12x40.8	S 12x40.8
12 ft.	S 6x12.5	S 6x12.5	S 7x15.3	S 10x25.4	S 12x31.8	S 12x40.8	S 12x40.8	S 18x54.7
14 ft.	S 6x12.5	S 6x12.5	S 7x15.3	S 10x25.4	S 12x31.8	S 12x40.8	S 12x40.8	S 18x54.7
16 ft.	S 6x12.5	S 7x15.3	S 8x18.4	S 10x25.4	S 12x31.8	S 12x40.8	S 18x54.7	S 18x54.7
18 ft.	S 7x15.3	S 8x18.4	S 10x25.4	S 12x31.8	S 12x31.8	S 18x54.7	S 18x54.7	S 20x66
20 ft.	S 7x15.3	S 8x18.4	S 10x25.4	S 12x31.8	S 12x40.8	S 18x54.7	S 18x54.7	S 20x66
22 ft.	S 8x18.4	S 10x25.4	S 12x31.8	S 12x40.8	S 12x40.8	S 18x54.7	S 20x66	S 20x66
24 ft.	S 10x25.4	S 10x25.4	S 12x31.8	S 12x40.8	S 18x54.7	S 20x66	S 20x66	S 24x80
26 ft.	S 10x25.4	S 10x25.4	S 12x40.8	S 18x54.7	S 18x54.7	S 20x66	S 18x54.7 w/C 9x13.4	S 24x80
28 ft.	S 10x25.4	S 12x31.8	S 12x40.8	S 18x54.7	S 12x40.8 w/C 8x11.5	S 18x54.7 w/C 9x13.4	S 18x54.7 w/C 9x13.4	S 20x66 w/C 9x13.4
30 ft.	S 10x25.4	S 12x31.8	S 12x40.8	S 18x54.7	S 12x40.8 w/C 8x11.5	S 18x54.7 w/C 9x13.4	S 18x54.7 w/C 9x13.4	S 20x66 w/C 9x13.4
32 ft.	S 12x31.8	S 12x40.8	S 18x54.7	S 12x40.8 w/C 8x11.5	S 15x42.9 w/C 8x11.5	S 18x54.7 w/C 9x13.4	S 18x54.7 w/C 10x15.3	S 20x66 w/C 9x13.4
34 ft.	S 12x40.8	S 12x40.8	S 18x54.7	S 15x42.9 w/C 8x11.5	S 15x42.9 w/C 8x11.5	S 18x54.7 w/C 9x13.4	S 20x66 w/C 9x13.4	S 20x66 w/C 9x13.4
36 ft.	S 12x40.8	S 12x40.8	S 12x31.8 w/C 9x13.4	S 15x42.9 w/C 8x11.5	S 15x42.9 w/C 8x11.5	S 18x54.7 w/C 20x20.7	S 20x66 w/C 9x13.4	S 20x66 w/C 12x20.7

* Rated capacity is based on maximum combined hoist and trolley weights of 500 pounds for 1/4, 1/2 and 1 ton hoists; 1100 pounds for 1-1/2 and 2 ton hoists; 1600 pounds for 3 and 4 ton hoists; 2000 pounds for 5 ton hoists. Bridge designed in accordance with CMAA Specification No. 74. Use ASTM A36 grade steel, first quality, free of rust and excessive mill scale.

** Beam sizes listed are American Standard I-Beam and Channel sections. Use ASTM A36 grade steel, first quality, free of rust and excessive mill scale.

American Standard Wide Flange Beam Selections

BEAM SIZES FOR VARIOUS SPANS								
Spans To	(*) RATED LOAD IN TONS OF 2000#							
	1/4	1/2	1	1-1/2	2	3	4	5
Push or Hand Geared Crane - 54" Wheelbase								
10 ft.	W 6x12	W 6x12	W 8x15	W 10x19	W 12x22	W 10x30	W 14x38	W 18x46
12 ft.	W 6x12	W 6x12	W 8x15	W 10x19	W 12x22	W 12x35	W 18x40	W 18x46
14 ft.	W 6x12	W 6x12	W 8x15	W 10x19	W 10x26	W 12x35	W 18x40	W 18x46
16 ft.	W 6x12	W 8x15	W 8x18	W 10x26	W 14x26	W 14x38	W 16x45	W 16x50
18 ft.	W 8x15	W 8x18	W 8x18	W 10x26	W 10x30	W 18x40	W 16x45	W 18x55
20 ft.	W 8x15	W 8x18	W 8x21	W 10x26	W 10x30	W 18x40	W 18x46	W 16x57
22 ft.	W 8x18	W 8x18	W 10x26	W 10x30	W 14x34	W 12x45	W 16x50	W 16x57
24 ft.	W 8x18	W 8x21	W 10x26	W 10x30	W 12x35	W 16x45	W 16x50	W 16x57
26 ft.	W 8x21	W 10x22	W 10x30	W 12x35	W 14x38	W 14x48	W 14x53	W 18x60
28 ft.	W 10x22	W 10x26	W 10x30	W 14x38	W 12x40	W 14x48	W 16x57	W 18x65
30 ft.	W 10x22	W 10x26	W 14x34	W 12x40	W 14x43	W 14x53	W 18x65	W 18x71
32 ft.	W 10x26	W 10x30	W 12x35	W 14x43	W 14x48	W 18x60	W 16x67	W 16x77
34 ft.	W 10x26	W 12x30	W 14x38	W 14x48	W 14x48	W 18x65	W 16x67	W 16x77
36 ft.	W 10x30	W 14x34	W 12x40	W 14x48	W 14x53	W 16x67	W 16x77	W 16x89
Motor Driven Crane - Single Drive - 36" and 54" Wheelbase								
10 ft.	W 6x12	W 6x12	W 8x15	W 10x19	W 12x22	W 12x35	W 18x40	W 18x46
12 ft.	W 6x12	W 6x12	W 8x15	W 10x19	W 10x26	W 12x35	W 18x40	W 18x46
14 ft.	W 6x12	W 6x12	W 8x18	W 10x26	W 14x26	W 14x38	W 10x45	W 16x50
16 ft.	W 6x12	W 8x15	W 8x18	W 10x26	W 10x30	W 18x40	W 16x45	W 14x53
18 ft.	W 8x15	W 8x18	W 8x21	W 10x26	W 10x30	W 18x40	W 18x46	W 16x57
20 ft.	W 8x18	W 8x18	W 8x21	W 10x30	W 10x30	W 10x45	W 12x50	W 16x57
22 ft.	W 8x18	W 8x21	W 10x26	W 10x30	W 12x35	W 16x45	W 16x50	W 16x57
24 ft.	W 8x18	W 8x21	W 10x26	W 14x34	W 14x38	W 14x48	W 14x53	W 18x65
26 ft.	W 8x21	W 10x26	W 10x30	W 12x35	W 12x40	W 12x50	W 16x57	W 18x65
28 ft.	W 10x22	W 10x26	W 10x33	W 12x40	W 12x40	W 14x53	W 18x65	W 18x71
30 ft.	W 10x26	W 10x30	W 12x35	W 12x40	W 12x45	W 14x53	W 16x67	W 14x74
32 ft.	W 10x26	W 10x30	W 14x38	W 12x45	W 14x48	W 14x61	W 16x67	W 16x77
34 ft.	W 10x30	W 14x34	W 12x40	W 14x48	W 14x53	W 16x67	W 16x67	W 16x89
36 ft.	W 10x30	W 12x35	W 12x40	W 14x53	W 14x61	W 16x67	W 16x77	W 16x89
Motor Driven Crane - Dual Drive - 72" Wheelbase								
38 ft.	W12x35	W12x40	W14x48	W14x61	W16x67	W16x77	W16x89	W18x97
40 ft.	W12x40	W12x45	W14x53	W16x67	W16x67	W16x89	W18x86	W21x101
42 ft.	W12x40	W14x48	W14x61	W16x67	W16x67	W18x86	W18x97	W21x101
44 ft.	W14x43	W14x48	W14x61	W16x67	W16x77	W18x86	W21x101	W21x111
46 ft.	W14x48	W14x53	W16x67	W16x77	W18x76	W18x97	W21x101	W21x111
48 ft.	W14x53	W14x61	W16x67	W18x76	W18x86	W21x101	W21x111	W21x122

* Rated capacity is based on maximum combined hoist and trolley weights of 500 pounds for 1/4, 1/2 and 1 ton hoists; 1100 pounds for 1-1/2 and 2 ton hoists; 1600 pounds for 3 and 4 ton hoists; 2000 pounds for 5 ton hoists. Bridge designed in accordance with CMAA Specification No. 74. Use ASTM A36 grade steel, first quality, free of rust and excessive mill scale.

Single Drive

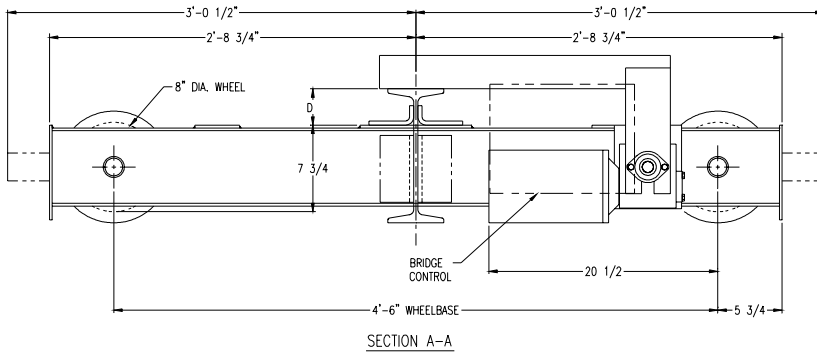

Beams (Depth)	D
6", 7", 8", 10" & 12"	3-1/4"
15", 18" & 20"	4-3/4"

$$J=7-3/4" + D + 3"$$

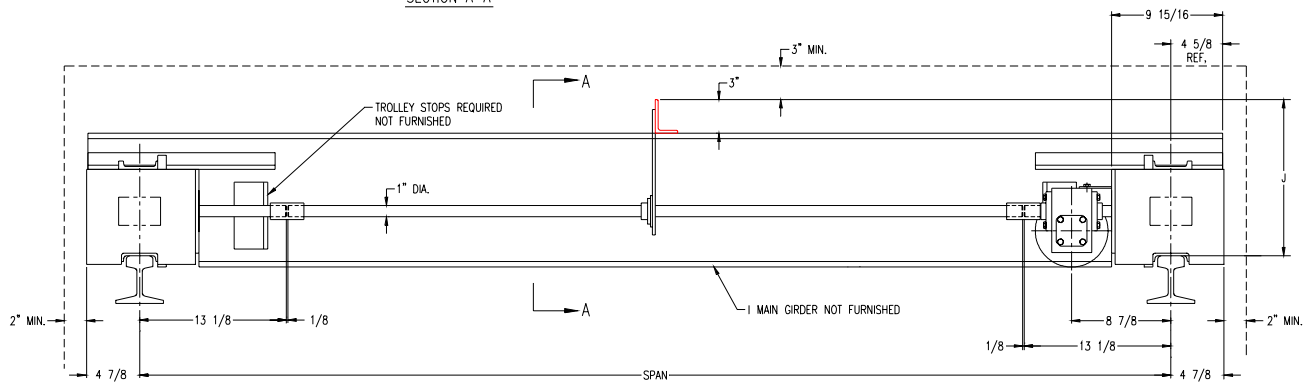

Dual Drive - 36' Spans*

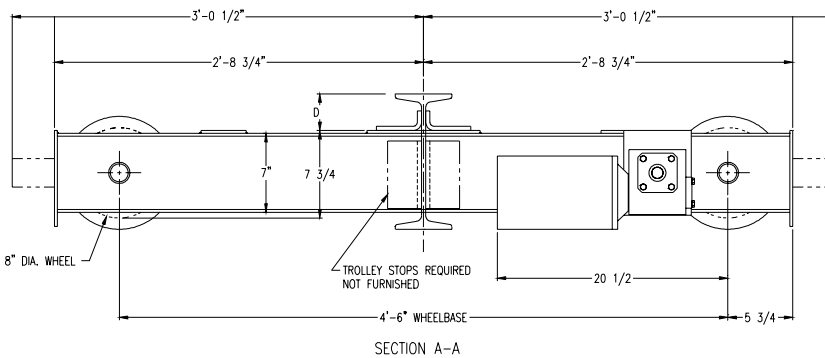

Beams (Depth)	D
6", 7", 8", 10" & 12"	3-1/4"
15", 18" & 20"	4-3/4"

$$J=7-3/4" + D + 3"$$

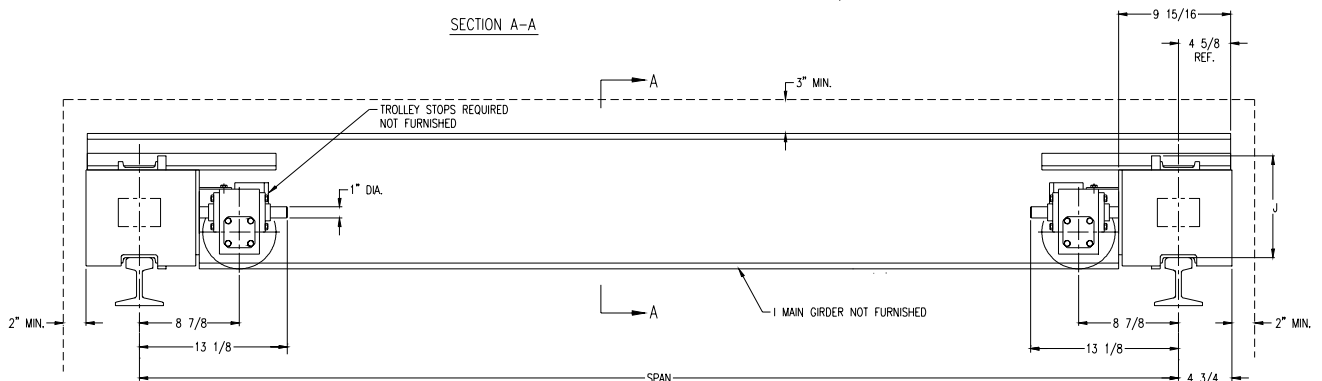

* For spans from 36' up to 48' consult factory.

Top Running

End truck frames are steel channel box section weldment for a strong, rigid construction. End truck plates serve as rail sweeps for bridge protection and anti-drop stops, as required by CMAA Specification No. 74. The standard truck wheelbase is 4'-6" or 6'-0", suitable for spans to 36 feet or 48 feet respectively, meeting the CMAA span to wheelbase ratio limit of 8 to 1. Wheels are 8" diameter of high strength ductile iron, with a hardness of 220 BHN. Wheels have cylindrical tread designed for a minimum recommended rail of ASCE 20 lbs. Maximum size runway rail for minimum CMAA Specification No. 74 float of ¼" is ASCE 45 lbs. Width between wheel flanges is 2-3/4". Wheel bearings are lifetime lubricated precision ball bearings. They provide a minimum of 5000 hours performance in accordance with CMAA Specification No. 74. Maximum allowable wheel load (determined in accordance with CMAA Specification No. 74) is 6500 pounds (per pair).

Underhung

The end truck is a rigid steel weldment, reinforced at the wheel axles and girder connection. The truck is welded of formed channel sides and structural steel plates complete with welded girder pads and end plates forming a rigid "U" shaped structure. The wheels are solid forged steel and rotate on two sealed lifetime-lubricated ball bearings. The wheels are heat treated with a hardness of 300 BHN. The single flange wheels have a compound tread for operation on American Standard I-beam or wide flange beams. Wheel diameter is 4 inch on 3 ton trucks and 6 ½ inch on 5 ton trucks. Patented track wheels are available for both capacities. The push type and geared type underhung end trucks are designed in accordance with CMAA Specification No. 74. The maximum wheel load is determined in accordance with CMAA Specification No. 74.

Gear Reducers

A right-angle, shaft mounted worm drive gear reducer can be mounted at either end of the bridge. The gear reducers can be mounted on either top running or underhung end trucks. Traverse reducer provides stopping motion of the bridge within a distance in feet equal to 10 percent of full load speed in feet per minute (traveling at maximum speed with maximum rated load).

	3-Ton 36' Span Underhung	3-Ton 48' Span Underhung	5-Ton 36' Span Underhung	5-Ton 36' Span Top Running	5-Ton 48' Span Top Running	Catalog Number
Traverse Speed	110 fpm	110 fpm	100 fpm	100 fpm	100 fpm	905376
Traverse Speed	70 fpm	70 fpm	65 fpm	70 fpm	70 fpm	905377
Traverse Speed	55 fpm	–	50 fpm	50 fpm	–	905378

Cross Shaft Support

The cross shaft support, with its antifriction lifetime-lubricated bearings, support the cross shaft. For hand geared and single drive motor driven cranes, cross shafts are required. The cross shafts are to be 1" diameter AISI 1018 cold drawn steel.

Cross Shaft Coupling

The cross shaft couplings connect the cross shaft to the pinion shaft at each end truck, as well as couple sections of cross shaft.

Motor

Drive motor is a ½ or a ¾ horsepower, NEMA design 30-minute rated TENV with Class "F" insulation squirrel cage motor. The motor is provided with thermal overload protection as standard, C-faced mounted to the gear reducer. Single speed, two speed, three phase, and single phase motors (½ hp only) are available. Voltages available in single and two speed are 208-230-460-575 volt-3ph-60Hz, Voltages available in single speed only are 115-230 volt-1ph-60 Hz. Consult factory for any other special speeds or voltages that are not shown.

Control Panel

The control panels include mainline contactor, 115-volt control circuit transformer with fused secondary terminal strip, bridge fusing and reversing contactor in a NEMA 1 enclosure. NEMA 4/12 panels are available as an option.

Fused Disconnect Switch

Fused disconnect switch box has positive power disconnect and crane fusing. NEMA 1 enclosure is standard with NEMA 4/12 available as an option.

Bridge Brake (optional)

Bridge brake is a disc type that is available as an option. The bridge's standard drive reducer is a worm that will stop the crane within the CMAA and OSHA requirements.

Electronic Acceleration Control (optional)

The electronic acceleration control is a solid state device for controlling the torque and time of acceleration of the bridge crane. The electronic acceleration control provides a more controlled acceleration and is less load sensitive than conventional ballast resistors.

Air Motor Drive Package – Catalog Number 904558 (optional)

Air motor drive packages are available in capacities up to 5 tons and spans to 36 feet. They can be mounted on the formed channel type end trucks that have geared wheels and drive pinions. Only one drive is required. The package includes air motor, gear reducer, control head with pendant throttle and air hose assembly with an 8' drop. Variable traverse speeds from 0-70 fpm are achievable. Filter, lubricator and regulator are recommended options.

Bridge Bumpers (optional)

Heavy duty rubber bumpers help cushion bridge end stop impact.

Other Options Available

Variable Frequency Control

Ballast Resistors

Thermal Overload Relays

Spark Resistance (Hand-geared and push type trucks)

Patented track

 WARNING
Improper application, installation, and use of crane kits can result in personal injury.
TO AVOID INJURY: <ul style="list-style-type: none">DO read, apply and install per assembly manual.DO install trolley stops.DO NOT exceed maximum capacityDO NOT use to lift people or loads over people.



414 West Broadway Ave.
P.O. Box 769
Muskegon, Michigan 49443-0769
(800) 955-5541
(800) 742-9270 FAX