

Series 84A

Plain or geared trolleys

Manufactured for heavy duty, industrial grade applications

CM series 84A trolleys feature fully sealed, precision bearings, heavy duty side frames and fully machined wheel tread for superior performance and long life — with minimal maintenance.

- Available in capacities from 1/4 through 25 ton with 30 through 50 ton trolleys available as tandem construction.
- Lifetime lubricated, precision ball bearings on trolleys through 3 ton capacity. Trolleys with capacities 4 tons and greater are equipped with eight sealed, Timken tapered roller bearings and grease fittings.
- Heavy rolled steel side frames extend beyond the wheels to provide these trolleys with superior strength, rigidity and added protection for the trackwheels. Units with capacities from 1/4 through 12 tons employ universal wheel treads for use on flat or tapered beam flanges. Units with capacities from 16 through 25 tons operate on American Standard I-beams with tapered flanges. For patented track, consult factory.
- Trolley wheels are fully machined from alloy cast iron and hardened for high strength and long life.
- Alloy steel axles and equalizer pins are heat treated for maximum strength and wear life.
- Geared versions have fully machined trackwheel gears and incorporate a swinging chain guide which keeps the hand chain aligned and free from jamming.
- Available to fit a broad range of wider flange beams and patented track applications not listed - contact factory.
- Made in the USA
- Spark resistant models available — add suffix “SR”

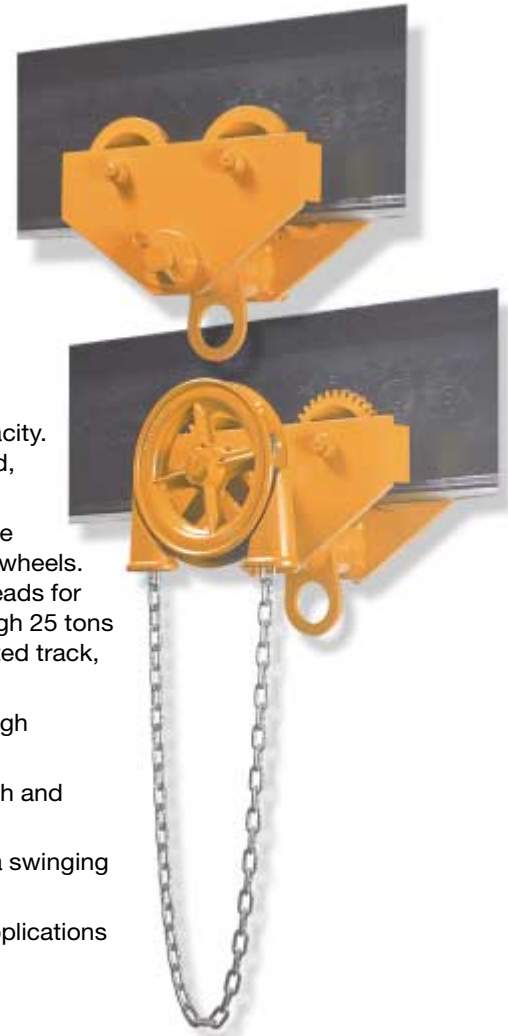

Specifications

Product code Plain	Geared	Rated capacity (tons)	Beam height (in.)	Flange width (in.)	Minimum radius curve (in.)	Approximate net weight	
						Plain	† Geared
1641-0025	1642-0025	1/4	4 - 12	2.66 - 5.00	20	23	38
1641-0050	1642-0050	1/2	4 - 12	2.66 - 5.00	20	23	38
1641-0100	1642-0100	1	5 - 12	3.00 - 6.00	24	43	62
1641-0150	1642-0150	1 1/2	5 - 12	3.00 - 6.00	24	45	65
1641-0200	1642-0200	2	6 - 18	3.33 - 6.25	30	67	90
1641-0300	1642-0300	3	6 - 18	3.33 - 6.25	30	70	93
1641-0400	1642-0400	4	8 - 24	4.00 - 7.00	36	155	184
1641-0500	1642-0500	5	8 - 24	4.00 - 7.00	36	160	188
1641-0600	1642-0600	6	8 - 24	4.00 - 7.00	36	160	188
1641-0800	1642-0800	8	10 - 24	4.62 - 8.00	60	300	347
1641-1000	1642-1000	10	10 - 24	4.62 - 8.00	60	310	360
1641-1200	1642-1200	12	10 - 24	4.62 - 8.00	60	310	360
1631-1600	1632-1600	16	18 - 24	6.00 - 8.00	96	800	895
1631-2000	1632-2000	20	18 - 24	6.00 - 8.00	96	845	955
1631-2500	1632-2500	25	18 - 24	6.00 - 8.00	120	1045	1200

For wide flange beam adaptation, patented track or for beams larger than standard - contact factory.

† Weight less hand chain. 8 Ft. standard zinc plated hand chain drop on geared trolley. Specify curve on order.

Series 84A

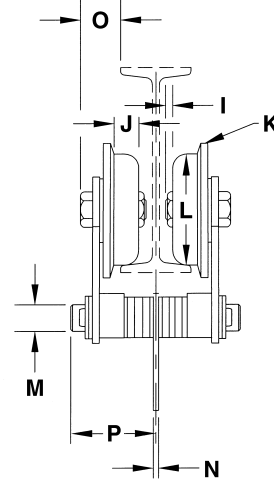
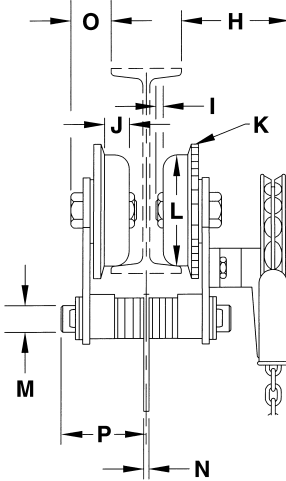
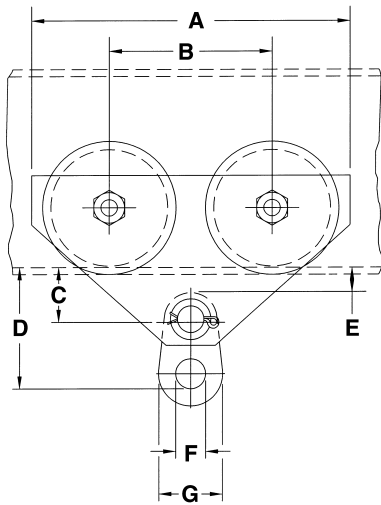

Cap. (tons)	A	B	C	D	E	F	G	H	I	J	K	L	M	N	O	P
1/4	11 1/2	6	17/8	47/8	7/8	13/4	23/4	6	—	7/8	4	27/8	1	1/4	2	4 1/8
1/2	11 1/2	6	17/8	47/8	7/8	13/4	23/4	6	—	7/8	4	27/8	1	1/4	2	4 1/8
1	13 1/4	6 3/4	2 1/4	5 3/8	1	13/4	3	6 1/8	—	1 1/8	5	3 3/4	1 1/4	1/4	1 3/4	4 3/4
1 1/2	13 1/4	6 3/4	2 1/4	5 3/8	1	2	3 1/4	6 1/8	—	1 1/8	5	3 3/4	1 1/4	3/8	1 3/4	4 3/4
2	15 5/8	7 5/8	2 5/8	6 3/4	1 1/8	2 1/8	3 5/8	6 1/8	—	1 1/8	6	4 1/2	1 1/2	3/8	2 1/8	5 1/4
3	15 5/8	7 5/8	2 5/8	6 7/8	1 1/8	2 1/4	4	6 1/8	—	1 1/8	6	4 1/2	1 1/2	1/2	2 1/8	5 1/4
4	18 3/4	8 1/2	3 1/4	8 3/8	1 1/4	2 3/4	4 3/4	8 1/8	1/8	1 3/8	8	6 3/8	2	5/8	2 5/8	6 1/8
5	18 3/4	8 1/2	3 1/4	8 5/8	1 1/4	3	5 1/2	8 1/8	1/8	1 3/8	8	6 3/8	2	5/8	2 5/8	6 1/8
6	18 3/4	8 1/2	3 1/4	8 5/8	1 1/4	3	5 1/2	8 1/8	1/8	1 3/8	8	6 3/8	2	5/8	2 5/8	6 1/8
8	23 5/8	10 5/8	3 7/8	10 5/8	1 3/8	3 1/2	6 1/2	9	1/8	1 11/16	10	8 1/4	2 1/2	3/4	3 1/4	6 7/8
10	23 5/8	10 5/8	3 7/8	11 1/8	1 3/8	4 1/2	8	9	1/8	1 11/16	10	8 1/4	2 1/2	1	3 1/4	6 7/8
12	23 5/8	10 5/8	3 7/8	11 1/8	1 3/8	4 1/2	8	9	1/8	1 11/16	10	8 1/4	2 1/2	1	3 1/4	6 7/8
16	28 1/4	14	5 7/8	15 1/4	2 1/2	4	9	14 1/2	5/16	2	13 1/2	11 3/4	3 1/4	1 1/2	7	8
20	28 1/4	14	5 7/8	16 5/8	2 1/2	4	10	14 1/2	5/16	2	13 1/2	11 3/4	3 1/4	1 3/4	7	8 1/4
25	28 1/4	14	5 7/8	16 3/4	2 1/8	4	10	14 1/2	5/16	2	13 1/2	11 3/4	3 1/4	1 3/4	7	8 1/4

Notes: All dimensions are in inches.
 Wheels with convex treads are standard on all capacities.
 20, 25, 30 and 40 ton trolleys can be furnished in tandem construction - Dimensions for 30 through 50 ton units available upon request.
 * Dimensions shown are for minimum beam size and will vary proportionately for larger beams.

⚠ WARNING

Overloading and improper use can result in injury

TO AVOID INJURY:

- Do not exceed working load limit, load rating or capacity.
- Do not use to lift people or loads over people.
- Use only CM alloy chain for overhead lifting.
- Read and follow all instructions.



COLUMBUS McKINNON CORPORATION

INDUSTRIAL PRODUCTS DIVISION
 AMHERST, NEW YORK 14228-1197
 800/888-0985 • 716/689-5400 • FAX 716/689-5644
 e-mail: cm.industrial@cmworks.com
www.cmworks.com

COLUMBUS McKINNON LIMITED
 11 Brook Road North
 P.O. Box 1106
 Cobourg, Ontario K9A4W5 Canada