

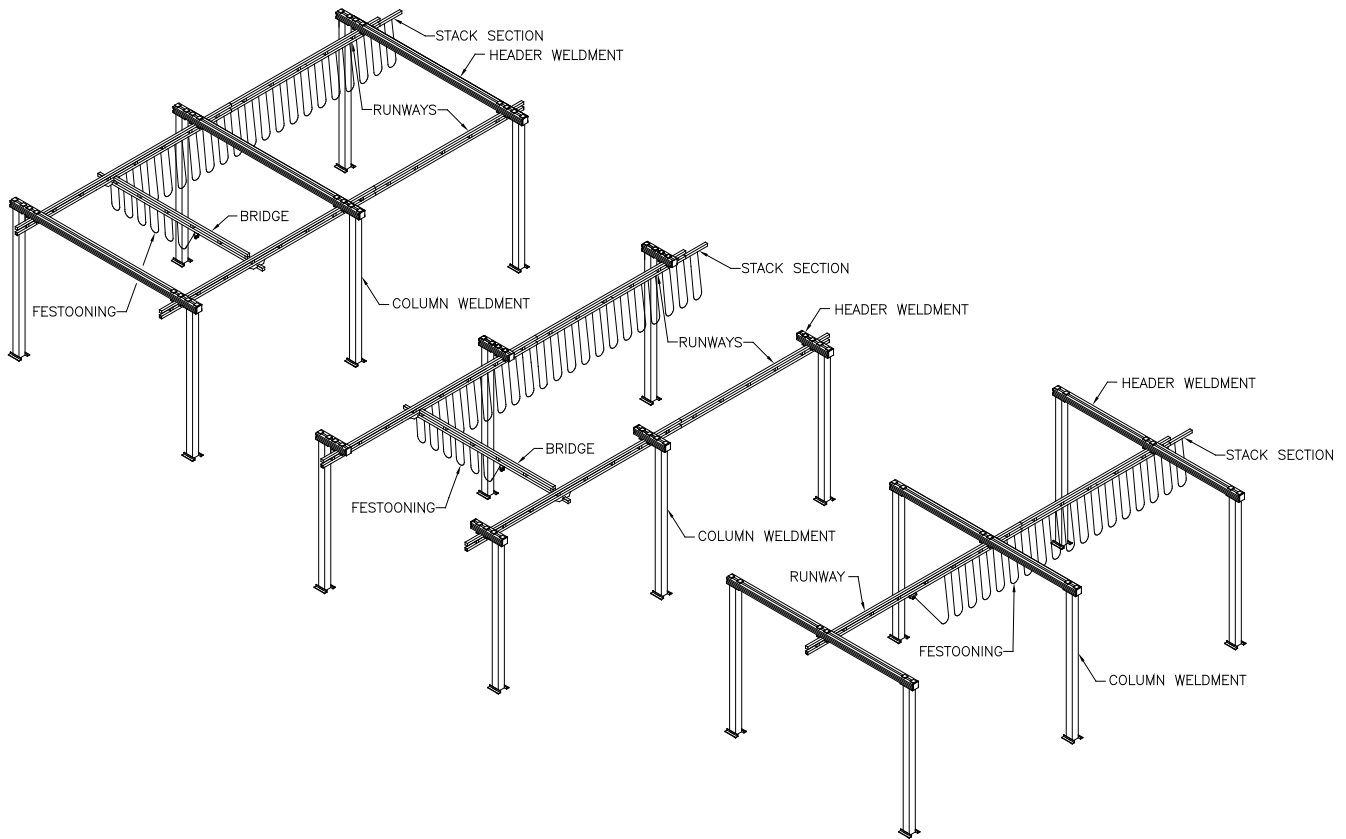

# LodeRail

# Installation, Operation, & Maintenance Manual



**IMPORTANT!  
DO NOT DESTROY**

## Free Standing Steel Work Station Bridge Crane

CM® LodeRail Customer Order No. / Serial No. \_\_\_\_\_

CM® LodeRail Dealer \_\_\_\_\_

Date \_\_\_\_\_

Month

Year

# TABLE OF CONTENTS

Introduction.....	1
<b>Installation</b>	
Step 1 - Pre-assembly .....	1-2
Step 2 - Column Weldment Installation .....	2
Step 3 - Header Weldment Installation.....	3
Step 4 - Runway Installation.....	4-5
Step 5 - Bridge and End Truck Installation.....	6-7
Step 6 - Hoist Trolley Installation.....	8-9
Step 7 - Festoon Stack Section Installation.....	10
Step 8 - Festooning Installation .....	11-13
Step 9 - Bridge and Runway Tagline Installation .....	13
Step 10 - Optional Accessories .....	14-15
Step 11 - Final Steps.....	15
Sway Bracing .....	15
Crane Operator Instructions.....	16
General Safety Suggestions.....	16
Limited Warranty .....	17
Inspection and Maintenance Schedule .....	18

Questions? Concerns? Comments? Please call (800) 888-0985 (US and Canada) or (716) 689-5400 (outside US).

# INTRODUCTION

Thank you for choosing a CM® LodeRail Free Standing Work Station Crane to solve your material handling needs. The innovative design and heavy-duty construction of CM® LodeRail Work Station Cranes will provide a superior quality product. All CM® LodeRail cranes are pre-engineered for powered hoist operation. The hoist weight allowance is 15% of the crane capacity (for example, a crane rated for 1000 pounds, allows for a 1000-pound live load plus 150 pounds for the weight of the hoist). There is also an allowance of 25% of the crane capacity for impact caused by hoist use. CM® LodeRail Work Station Cranes will provide many years of dependable service by following the installation and maintenance procedures described herein.

***Dimensions contained in this installation manual are for reference only and may differ for your particular application. Please refer to the enclosed General Arrangement Drawing for actual dimensions.***

**Normal safety precautions:** These include, but are not limited to:

- Checking for obstructions in crane travel
- Checking that all bolts and threaded rods are tight and have lockwashers
- Making sure that endstops are in place
- Making sure that festooning cannot be snagged or pinched, whether it is electric or pneumatic
- For additional safety precautions, see page 16.

## WARNING

A minimum of a 6"-thick reinforced concrete floor is required. CM® LodeRail assumes no responsibility for adequacy or integrity of the mounting surface. Support assemblies are designed to AISC (American Institute of Steel Construction) specifications. If no movement of the support assembly is required, additional bracing (not included) to the building steel structure is recommended. See back cover for maintenance schedule.

## WARNING

Equipment described herein is not designed for, and should not be used for, lifting, supporting or transporting humans. Failure to comply with any one of the limitations noted herein can result in serious bodily injury and/or property damage. Check State and Local regulations for any additional requirements.

## WARNING

Crane cannot be utilized as a ground: A separate ground wire is required. For example, systems with 3-phase power require three conductors plus one ground wire.

## WARNING

Reference the American Institute of Steel Construction (AISC) Manual of Steel Construction (9th edition), Part 5, Specification for Structural Joints using ASTM A325 or A490 Bolts (section 8.d.2) for the proper procedures to follow when using any torque tightening method.

# INSTALLATION

## STEP 1 - PRE-ASSEMBLY

- ➡ **TIP:** Packing list can be found in plastic pocket attached to hardware box: General Arrangement Drawing can be found inserted in this installation manual.
- ➡ **TIP:** Recommended guidelines to help you determine anchor bolt size are supplied on page 2 (anchor bolts are not included).

1.1 Check packing list to make sure correct quantity of parts is included.

1.2 Tools and materials typically needed to assemble crane are as follows:

- Mallet
- Chalk line
- Hand tools
- Shop brush
- Steel shims
- Large square
- Heavy duty drill
- Torque wrench (able to torque up to 95 ft.-lbs.)
- Tape measure
- Ladders/man lifts
- Leveling tools (transit, laser level, water level, etc.)
- Lifting device to lift heavy runways, bridges, headers
- Anchor bolts (see 1.3 for guidelines in determining size)

## STEP 1 - PRE-ASSEMBLY (CONTINUED)

1.3 Recommended guidelines for determining bolt size and type:

**Anchor bolts must:**

- be 3/4" in diameter.
- be grade 5 or better.
- be embedded **at least 4"** into floor, not to exceed 3/4 of floor depth (**diagram 1A**).

**Note:** A minimum 6"-thick reinforced concrete floor is required.

- have a **minimum** of two threads above nut.

**Note:** Free Standing Work Station Bridge Crane foundation requirements are based on a soil pressure of 2500# per square foot. Concrete recommendations for the Free Standing Work Station Bridge Crane foundation is 3000# per square inch of compressive concrete.

**Note:** Chemical (epoxy) anchor bolts are recommended.

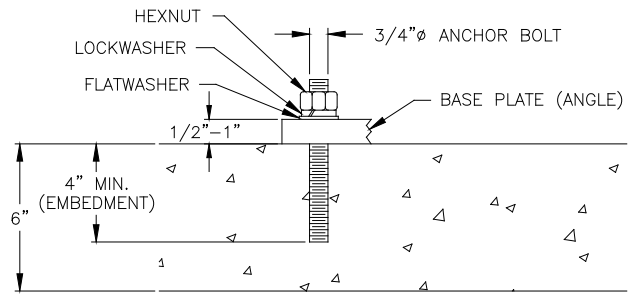

Diagram 1A. Typical anchor bolt embedment.

## STEP 2 - COLUMN WELDMENT INSTALLATION

**IMPORTANT:** Be sure that column cap plate (top of column) is oriented in direction of header weldment.

- 2.1 Lay out and mark on floor exact position of column weldments prior to proceeding with installation (refer to enclosed **General Arrangement Drawing** for recommended dimensions and column weldment location).
- 2.2 Position first column weldment in place. Orient column cap plate (top of column) (**diagram 2A**).
- 2.3 While supporting column weldment, drill holes in concrete floor using pre-drilled holes in column weldment base as a guide (use drill bit size recommended by anchor bolt manufacturer). Vacuum or brush away cement dust.
- 2.4 Install anchor bolts (not included) and hardware according to manufacturer's installation directions and requirements.
- 2.5 Check to see if column weldment is plumb. If column weldment is not plumb, loosen anchor bolt nuts and place steel shims (not included) or grout (not included) under base of column weldment until plumb. After column weldment is plumb, tighten all nuts.
- 2.6 Install remaining column weldments (repeat Steps 2.2 through 2.5).

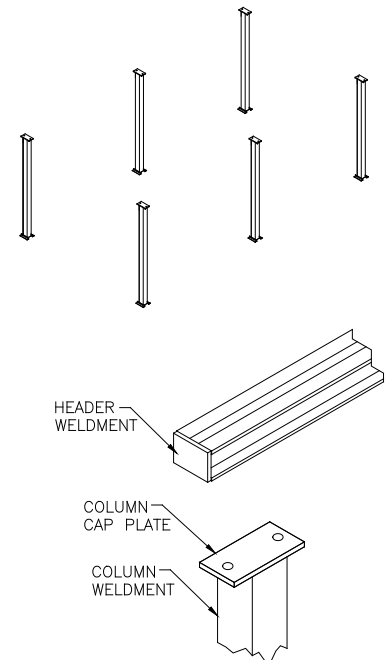

Diagram 2A. Orienting column cap plate.

### ATTENTION

Support assemblies can be bolted together on the floor then lifted into position to bolt to floor if you have an area large enough to assemble them.

## STEP 3 - HEADER WELDMENT INSTALLATION

**IMPORTANT:** Threaded rod for header weldment installation is either the same length or shorter than threaded rod used for runway hangers; do not confuse the two.

- 3.1 Lift and position header weldment onto two secured column weldments (refer to enclosed **General Arrangement Drawing** for recommended dimensions and header weldment location). Using clamp plates and hardware provided, attach header weldment to column weldment (refer to **diagram 3A** for 2-bolt column cap plate, **diagram 3B** for 4-bolt column cap plate and **diagram 3C** for 6-bolt column cap plate).
- 3.2 Tighten hardware. Refer to **chart 3A** for proper nut torque.

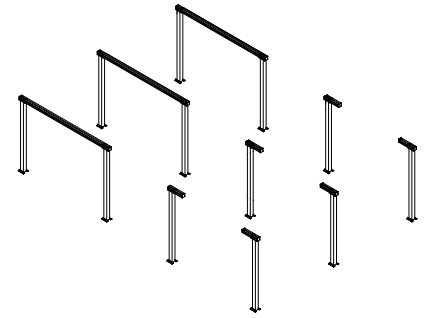

TORQUE CHART	
*Bolt Diameter	Torque
1/2"	50 ft.-lb.
5/8"	95 ft.-lb.
3/4"	150 ft.-lb.

**Chart 3A.** Torque Chart.  
\*Note: All bolts shall be SAE Grade 5 or equal.

**WARNING**

There must be a minimum of two threads showing at both ends of the threaded rod.

- 3.3 Install remaining header weldments (repeat Steps 3.1 through 3.2).

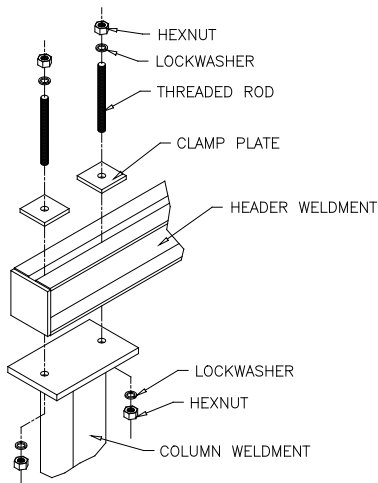

**Diagram 3A.** Installing header weldments on 2-bolt column cap plates.

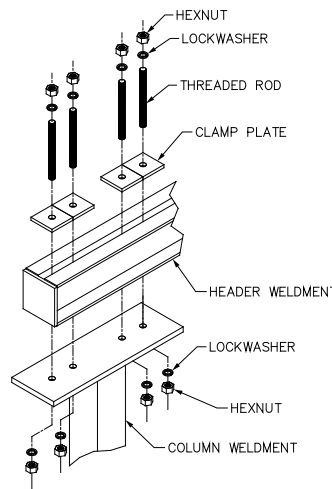

**Diagram 3B.** Installing header weldments on 4-bolt column cap plates.

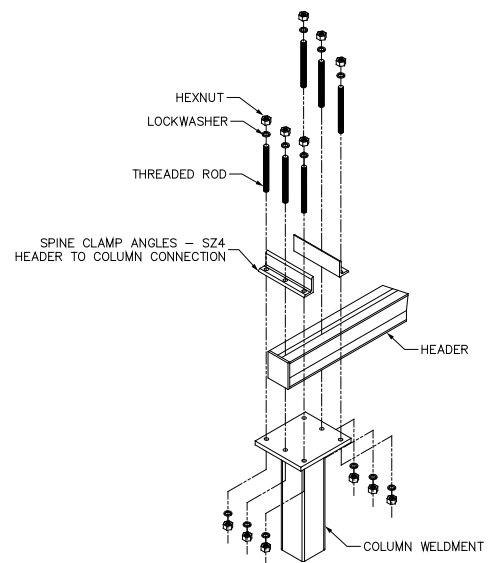

**Diagram 3C.** Installing header weldments on 6-bolt column cap plates.

## STEP 4 - RUNWAY INSTALLATION

- **IMPORTANT:** Keep in mind that splice joints must be within 48" of header center.
- **IMPORTANT:** The runways must be parallel to allow the crane to move (especially in larger capacities).

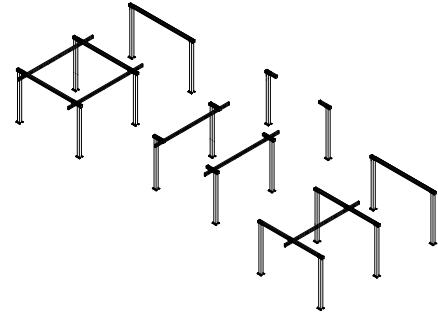

### Runways to Header Weldment Connections

- 4.1 Suspend runway section under installed support structure (refer to enclosed **General Arrangement Drawing** for recommended dimensions and runway location).
- 4.2 Using spine clamp angles, clamp plates, and hardware provided, attach runway section to header weldment (**diagram 4A, 4B or 4C**).

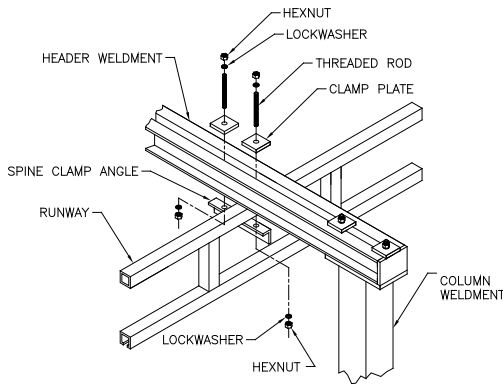

**Diagram 4A.** Attaching runway to header weldment (standard hangers).

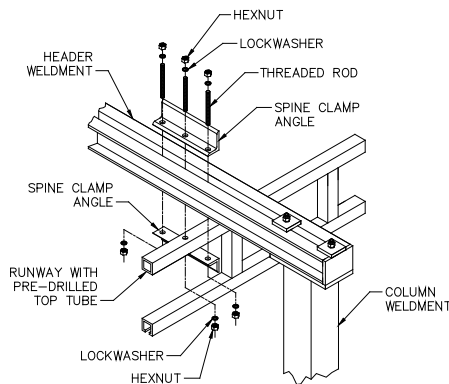

**Diagram 4B.** Attaching runway to header weldment (3-hole hangers).

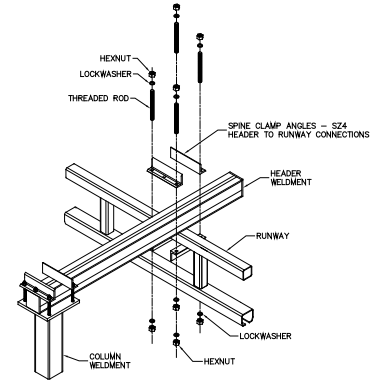

**Diagram 4C.** Attaching runway to header weldment (Seismic Zone IV)

### WARNING

If 3-hole hangers are being used, one threaded rod must be secured through the runway top tube. Failure to do so may result in the runway falling to the floor.

- 4.3 Check to make sure that runway is level (within  $\pm 1/32$ ") and parallel to opposite runway.

### WARNING

Do not deviate from the bridge "span" dimension shown on the General Arrangement drawing. Bridge "span" is the distance between runways (centerline to centerline).

- 4.4 Tighten hanger hardware (**chart 3A**, page 3, for proper torque rating).

### WARNING

There must be a minimum of two threads showing at both ends of the threaded rod.

- 4.5 If you **DO NOT** have additional runways to install, go to Step 4.13, on page 5. Otherwise proceed to Step 4.6 on page 5.

## STEP 4 - RUNWAY INSTALLATION (CONTINUED)

**IMPORTANT:** To install additional runway sections, runways must be spliced together.

### WARNING

Do not deviate from the dimensions specified in the General Arrangement Drawing for maximum space from header center to splice joint. Typically 48" maximum.

#### Splice Joint Instructions

- 4.6** Attach splice hardware to all joints. Slide splice joint over track portion of installed runway.
- 4.7** Lift next runway section into position for splicing to previously installed runway, bringing runway ends together. Maximum gap between ends of load carrying flange shall be less than or equal to 16" (1.5mm). Center lower splice joint over the two track ends (**diagram 4D**).

- 4.8** Place a truss splice plate on each side of runway truss tube and bolt into place (**diagram 4D**). "Hand tighten" bolts.

**Note:** Do not torque bolts until track has been attached to header weldment and adjusted for smooth transition - Steps 4.9 through 4.10.

- 4.9** Track running-surface misalignment at joints shall be adjusted within 1/32" (1mm) when installed.

- 4.10** To attach runway to header weldment, repeat Steps 4.2 through 4.4, on page 4.

- 4.11** To adjust track for smooth transition, use bolts along **top of splice joint** to force track down onto lower flanges of splice. Check to see that transition from one track to the other is smooth: no raised areas to inhibit trolley or end truck operation. Use bolts along the **sides of splice joint** to align track laterally. Check to see that track portion of runway is horizontally and vertically flush: transition from one track to the other is smooth. Tighten jam nuts to lock bolts in place (**diagram 4E**).

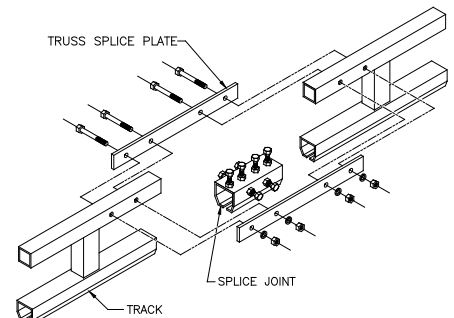
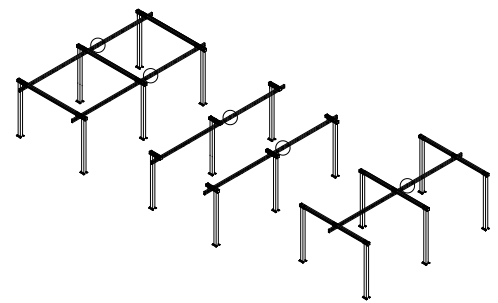

**Diagram 4D.** Splicing tracks together.

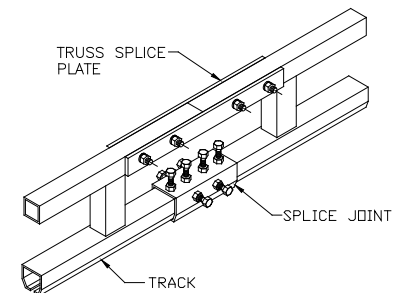
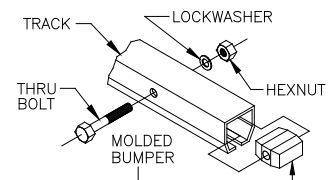

**Diagram 4E.** Spliced tracks.

### WARNING

Do not over-tighten bolts on splice joints; this may permanently deform track and cause binding.

- 4.12** Tighten nuts on truss splice plate (**chart 3A**, page 3, for proper torque rating).
- 4.13** Repeat Steps 4.6 through 4.11 for remaining runways.
- 4.14** Install end stops (**diagram 4F**) (molded bumper with thru bolt) to runway end opposite festooning end (leaving festooning end open for bridge installation).



**Diagram 4F.** Installing end stop.

## STEP 5 - BRIDGE AND END TRUCK INSTALLATION

- **IMPORTANT:** ONLY ONE end truck is clamped to the bridge; the other is not. The clamping end truck must be oriented with the festooning side of the track (refer to Step 8, page 11, for festooning). The non-clamping end truck allows adjustment for any runway misalignment.
- **IMPORTANT:** Extended end truck should be assembled before attaching to bridge.

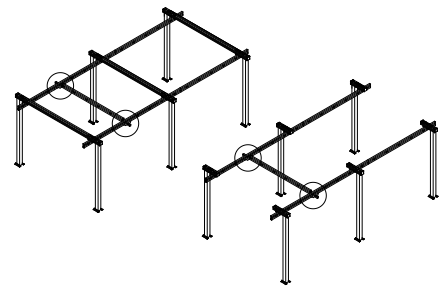

- 5.1 Make sure end stops have been installed in the runway end opposite the festooning (leaving festooning end open for bridge installation).
- 5.2 Prior to adding bridge, clean inside flanges of track with clean, dry cloth (**do not use any kind of cleaning solution**) to remove grit or debris that may have collected during shipping, storage, or installation.
- 5.3 If your end trucks look like:

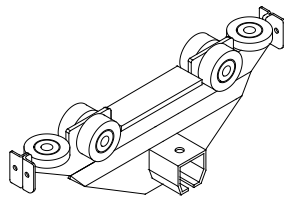

(Shipped Assembled)  
go to Step 5.4

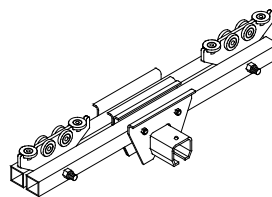

(Shipped Unassembled)  
go to Step 5.7

### ➤ Standard End Trucks

- 5.4 Slide an end truck over festooning end of bridge (refer to the **General Arrangement Drawing** for exact end truck location, end truck sleeve must be 1" (+/- 1/4") from first vertical) and clamp into place with hardware provided (**diagram 5A**).

**Note:** The festooning end of the bridge will have a hole that is inset the same or greater distance from the end of the bridge than the hole in the opposite end of the bridge.

- 5.5 Slide and position the non-clamping end truck on the other end of bridge (refer to the **General Arrangement Drawing** for exact location, end truck sleeve must be 1" (+/- 1/4") from first vertical).
- 5.6 Go to Step 5.16, on page 7.

### ➤ Extended End Trucks

- 5.7 Locate extended end truck tubes, support weldment, wheel plates, and required hardware.
- 5.8 Slide an extended end truck tube halfway through each side of the end truck support weldment (**diagram 5B**). Insert a support bolt in each hole of the support weldment.
- 5.9 Place nylock nut on end of each bolt and tighten snug against end truck support weldment.

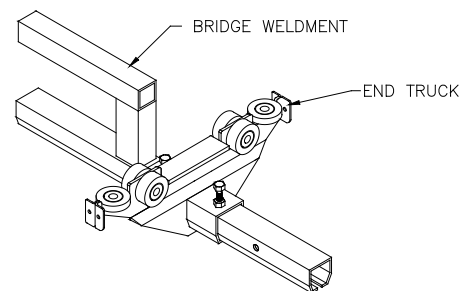

**Diagram 5A.** Installing standard clamping end truck. See **NOTE**.

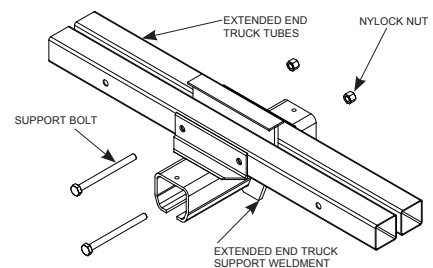

**Diagram 5B.** Assembling extended end truck.

### WARNING

Do not "over-tighten" nylock nut; this could cause damage to end trucks. Nylock nut can only be used once. If this item is disassembled, then nut must be replaced.

## STEP 5 - BRIDGE AND END TRUCK INSTALLATION (CONTINUED)

- **IMPORTANT:** ONLY ONE end truck is clamped to the bridge; the other is not. The clamping end truck must be oriented with the festooning side of the track (refer to Step 8, page 11, for festooning). The non-clamping end truck allows adjustment for any runway misalignment.
- **IMPORTANT:** Extended end truck should be assembled before attaching to bridge.

### Extended End Trucks (continued)

- 5.10 Place a wheel plate between the end truck tubes. Insert 5/8" dia. bolt into first tube, through the wheel plate and out the opposite tube (*diagram 5C*).
- 5.11 Place nylock nut on end of bolt and tighten snug against extended end truck tube. **Note:** When tightening this lock nut make sure that wheel plate pivots freely.

### WARNING

Do not "over-tighten" nylock nut; this could cause damage to end trucks. Nylock nut can only be used once. If this item is disassembled, then nut must be replaced.

- 5.12 Repeat steps 5.10 and 5.11 for remaining wheel plate.
- 5.13 Repeat steps 5.7 to 5.12 for remaining extended end trucks.
- 5.14 Slide an end truck over festooning end of bridge (refer to the **General Arrangement Drawing** for exact end truck location, end truck sleeve must be 1" (+/- 1/4") from first vertical) and clamp into place (*diagram 5D*).

**Note:** The festooning end of the bridge will have a hole that is inset the same or greater distance from the end of the bridge than the hole in the opposite end of the bridge.

- 5.15 Slide and position the non-clamping end truck on the other end of bridge (refer to the **General Arrangement Drawing** for exact location, end truck sleeve must be 1" (+/- 1/4") from first vertical).
- 5.16 Install an end stop to the end of the bridge opposite the festooning (*diagrams 5E* or *5F*).
- 5.17 Lift bridge up to runways and simultaneously insert end trucks into open ends of runways. Make sure festooning end of bridge is oriented with festooning runway. For information on festooning, refer to Step 8, on page 11.
- 5.18 **Immediately** install end stops in open ends of runways to prevent bridge from exiting runways (*diagrams 5E* or *5F*).
- 5.19 Roll bridge down length of runways to check for smooth travel. If travel is not smooth, check track for level and parallel (Step 4.3, page 4) and check to make sure that only one end truck on bridge is clamped.

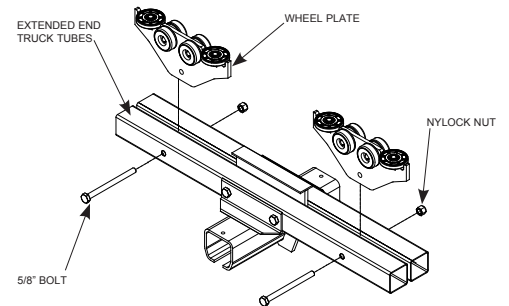

**Diagram 5C.** Installing wheel plates.

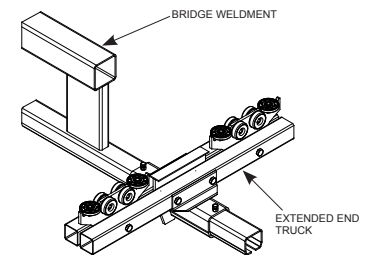

**Diagram 5D.** Installing extended clamping end truck. See **NOTE**.

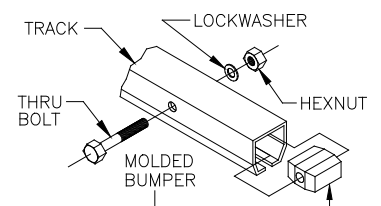

**Diagram 5E.** Installing end stop.

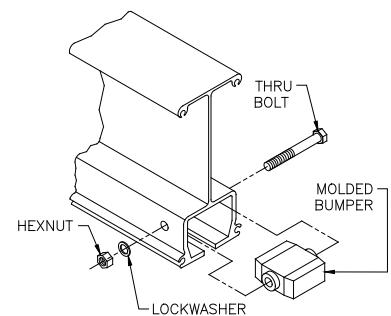

**Diagram 5F.** Installing end stop.

## STEP 6 - HOIST TROLLEY INSTALLATION

6.1 If your hoist trolley looks like:

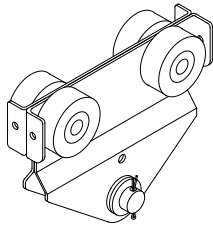

(shipped assembled)  
go to Step 6.2

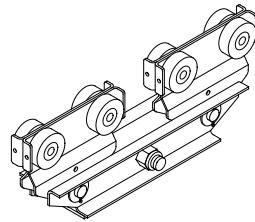

(shipped assembled)  
go to Step 6.15

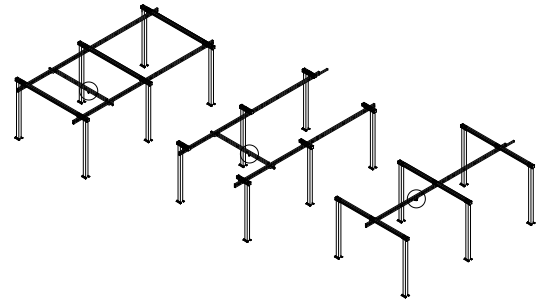

### 250#, 500#, 1000# and 2000# Hoist Trolley

- 6.2 Clean inside flanges of track with a clean, dry cloth (**do not use any kind of cleaning solution**) to remove grit or debris that may have collected during shipping, storage, or installation.
- 6.3 Be sure end stop is installed opposite the festooning end of bridge/monorail.
- 6.4 Attach hoist to hoist trolley by snapping hoist suspension hook over the trolley saddle clevis pin of hoist trolley.
- 6.5 If hoist suspension is too large or hoist has a suspension device other than a hook, remove trolley saddle clevis pin and install suspension device (by others). Insert clevis pin back into place. Slide washers on clevis pin and insert cotter pin through trolley saddle clevis pin (**diagrams 6A, 6B, and 6C**).

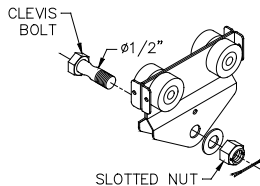

**Diagram 6A.** Installing hoist on 250# hoist trolley.

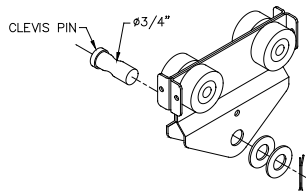

**Diagram 6B.** Installing hoist on 500# hoist trolley.

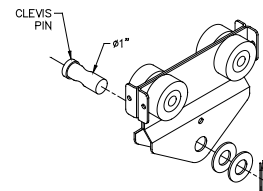

**Diagram 6C.** Installing hoist on 1000-2000# hoist trolley.

6.6 Bend back both legs of cotter pin (**diagram 6D**).

### WARNING

Fully bend both legs of cotter pin (**diagram 6D**). If cotter pin is cracked or fatigued it must be replaced.

6.7 If a tow arm **is not** being utilized on the trolley, go to Step 6.12, on page 9.

If a tow arm **is** being utilized on the trolley, go to Step 6.8.

**Note:** Festoon tow arms are **not** recommended for use on 4000# systems or systems with extended end trucks. They are **not necessary** for systems with festoon trolleys.

- 6.8 Remove wheels from festoon end of trolley (as needed). Keep snap rings.
- 6.9 Assemble the tow arm weldment on the festooning end of the hoist trolley (**diagram 6E**).
- 6.10 Re-assemble wheels and snap rings (as needed).
- 6.11 After the hoist trolley has been installed, loosen nuts on end of U-bolt enough to thread cable/air hose between the two legs of the U-bolt and festoon clamp plate. Secure cable/air hose by tightening nuts at the end of the U-bolt, forcing the festooning clamp plate snug against the cable/air hose.

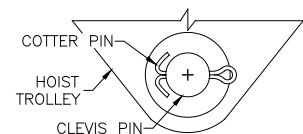

**Diagram 6D.** Installing cotter pin through trolley saddle clevis pin.

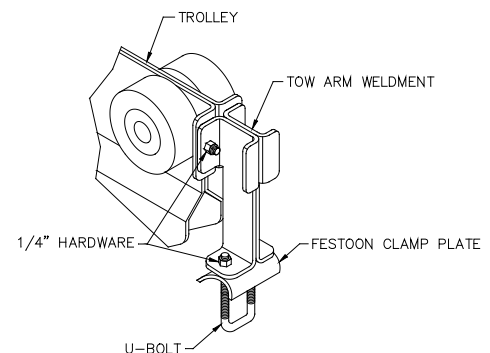

**Diagram 6E.** Installing tow arm on trolley.

## STEP 6 - HOIST TROLLEY INSTALLATION (CONTINUED)

- 6.12 Roll hoist trolley into open end of track on bridge/monorail.
- 6.13 Install end stop on the festooning end of bridge/monorail (*diagram 4E*, on page 5).
- 6.14 If you have tagline, go to Step 9, on page 13.  
If you **do not** have festooning, go to Step 11, on page 15.  
If you **do not** have a festoon stack section, go to Step 8, on page 11.  
Otherwise go to Step 7, on page 10.

### Loadbar Hoist Trolley 4000#

- 6.15 Clean inside flanges of track with a clean, dry cloth (**do not use any kind of cleaning solution**) to remove grit or debris that may have collected during shipping, storage, or installation.
- 6.16 Be sure end stop is installed opposite the festooning end of bridge/monorail.
- 6.17 Bend **both legs** of all cotter pins (*diagram 6F*).

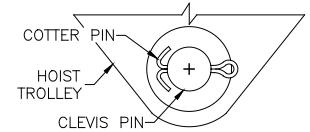

**Diagram 6F.** Installing cotter pin through trolley saddle clevis pin.

### WARNING

Fully bend both legs of cotter pin (*diagram 6F*). If cotter pin is cracked or fatigued it must be replaced.

- 6.18 Attach hoist to hoist trolley by snapping hoist suspension hook over the clevis bolt (center bolt) on hoist trolley loadbar.

### WARNING

Hang hoist from clevis bolt (center bolt) of hoist trolley only.

- 6.19 If hoist suspension hook is too large or hoist has a suspension device other than a hook, you will need to remove clevis bolt and install suspension device (by others). Insert clevis bolt back into place. Place nylock nut on end of bolt and tighten (*diagram 6G*).

### WARNING

Be sure to tighten nut on the clevis bolt (center bolt) of hoist trolley. **Do not “over-tighten” nylock nut:** could cause damage to trolleys. Nylock nut on clevis bolt should only be used once. If this item is disassembled, then nut must be replaced.

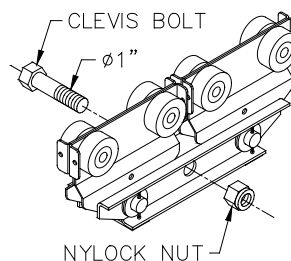

**Diagram 6G.** Installing hoist on loadbar hoist trolley.

- 6.20 Roll hoist trolley into open end of track on bridge/monorail.
- 6.21 Install end stop on festooning end of bridge/monorail (*diagram 4E*, on page 5).
- 6.22 If you have tagline, go to Step 9, on page 13.  
If you **do not** have festooning, go to Step 11, on page 15.  
If you **do not** have a festoon stack section, go to Step 8, on page 11.  
Otherwise go to Step 7, on page 10.

## STEP 7 - FESTOON STACK SECTION INSTALLATION

**TIP:** Festoon stack section allows festooning to stack up at the end of the system, permitting full use of runway.

7.1 Remove end stop on festooning end of runway.

➤ **For All Systems With Festoon Gliders, or Systems With Festoon Trolleys and 1000, 2000, or 4000 Series Track (diagram 7A)**

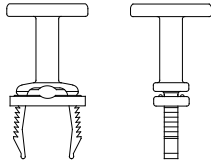

**Festoon Glider**

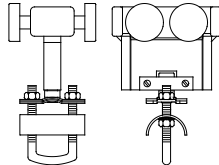

**Festoon Trolley**

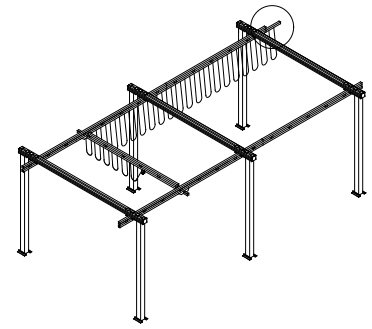

7.2 Slide festoon stack section over open end of runway.

7.3 Re-install end stop (diagram 7A).

7.4 Use leveling screws located at top of festoon stack section to align it with the runway.

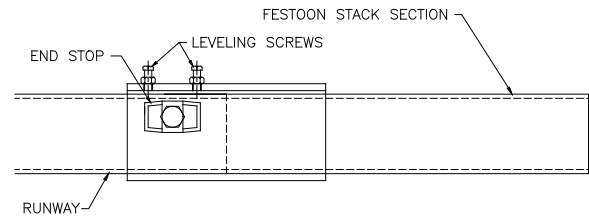

**Diagram 7A. Installing festoon stack section.**

➤ **For Systems With Festoon Trolleys and 250 or 500 Series Track (diagram 7B)**

**Note:** Welding is required to attach the festoon stack section to the runway when using festoon trolleys with 250 or 500 series track.

7.5 Slide festoon stack section over open runway end.

### WARNING

Do not over-tighten leveling screws; this will cause permanent damage to the track.

7.6 Use leveling screws located at top of festoon stack section to align it with runway.

7.7 Weld festoon stack section to runway at specified locations (diagram 7B).

### WARNING

All welds must meet American Welding Society (AWS) specification D1.1 using E70xx electrodes.

**Note:** Because trolleys are too large to roll under the end stop on the 250 and 500 series track, the end stop and accompanying hardware (which held the festoon stack section to the runway) is positioned at the end of the festoon stack section. To prevent festoon stack section from sliding off the runway, the festoon stack section is welded.

7.8 Install end stop (removed in step 7.1) in end of festoon stack section (diagram 7B).

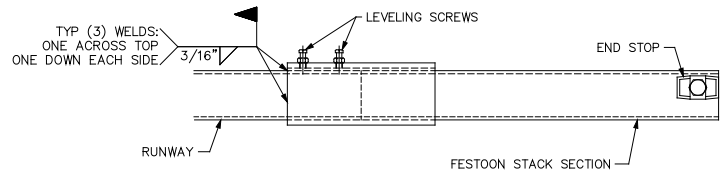
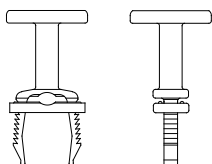

**Diagram 7B. Welding festoon stack section on 250-500# series track.**

## STEP 8 - FESTOONING INSTALLATION

- **TIP:** Festoon gliders are comprised of a glider body (with upper saddle) and a lower saddle (a separate piece that clips onto the glider body).
  - **TIP:** Enough carriers (festoon gliders or festoon trolleys) are supplied to support festoon cable every 6' on runways and every 3' on bridges.
- Note: Every 6' on vacuum hose trolley.

8.1 If you are using:



festoon gliders, go to Step 8.2

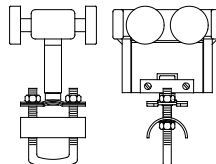

festoon trolleys, go to Step 8.8

### Festoon Gliders

8.2 Slide festoon gliders through open end of the bridge that corresponds with festooning on runway. Space festoon gliders every 3'-0" along bridge.

8.3 Slide festoon clamp into place at festooning end of bridge and tighten clamp bolt (**diagram 8A**).

**Note:** Rotate clamp 90° to be perpendicular to bridge to avoid interference with column.

8.4 Install end stop (molded bumper with thru bolt) in open end of bridge (**diagram 8B**).

8.5 Slide festoon gliders into end of **runway** track (on festooning side of runway). Space festoon gliders every 6'-0" along runway, between bridge and festoon stack section.

8.6 Slide festoon clamp into end of runway and tighten clamp bolt (**diagram 8A**). Tighten until lockwasher is flat.

8.7 Proceed to Step 8.14, on page 12.

➤ **IMPORTANT:** Before installing festoon trolleys in 250 and 500 series track, the molded bumper (on festooning end of runway) must first be removed.

### Festoon Trolleys

8.8 Roll festoon trolleys through open end of **bridge** that corresponds with festooning on runway. Space festoon trolleys every 3'-0" along bridge.

**Note:** Every 6'-0" for vacuum hose festooning.

8.9 Slide festoon clamp/vacuum hose clamp into place at festooning end of bridge and tighten clamp bolt (**diagrams 8C and 8D**).

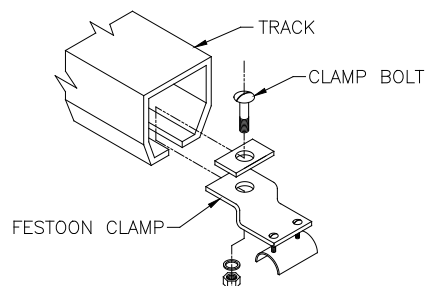
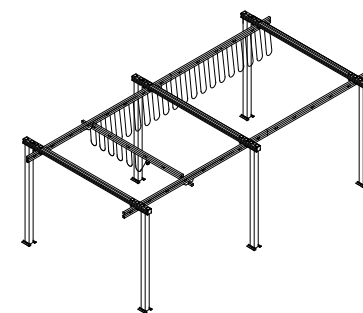

**Diagram 8A.** Installing festoon clamp on runway or bridge.

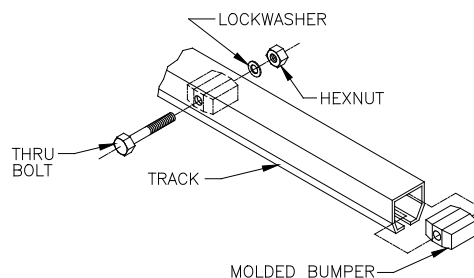

**Diagram 8B.** Installing end stop on bridge.

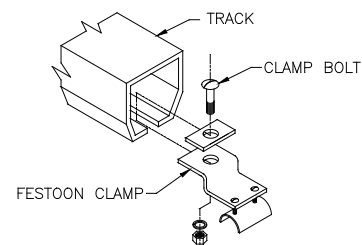

**Diagram 8C.** Installing festoon clamp.

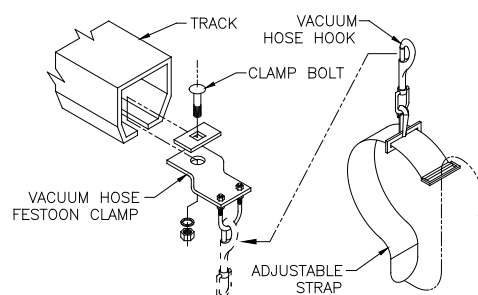

**Diagram 8D.** Installing vacuum hose clamp.

## STEP 8 - FESTOONING INSTALLATION (CONTINUED)

**NOTE:** Air Swivels should be used at either end of hose to reduce twist.

**8.10** Install end stop (molded bumper with thru bolt) in open end of bridge (*diagram 8E*).

**8.11** Roll festoon trolleys into end of **runway** track (on festooning side of runway). Space festoon trolleys every 6'-0" along runway, between bridge and festoon stack section. **On 250 or 500 series track, end stop on runway must first be removed to install trolleys.**

**8.12** Slide festoon clamp/vacuum hose clamp into festooning end of runway and tighten clamp bolt (*diagrams 8C and 8D*, page 11).

**8.13** If using 250 or 500 series track, re-install end stop in runway (*diagram 8E*).

**8.14** **Installing Festoon Electric Cable/Air Hose/Vacuum Hose:**

Gliders are designed to accept 4-conductor, electric flat cable (#12 or #14 gauge). Festoon trolleys are designed to accept 4-conductor, electric flat or round cable (#12 or #14 gauge) or air hose (maximum: 7/8" outside diameter).

### WARNING

Crane cannot be utilized as a ground: A separate ground wire is required. For example, systems with 3-phase power require 3 conductors plus one ground wire.

#### Electric Cable with Festoon Gliders

Thread electric cable between upper and lower saddles of glider. Secure electric cable by pushing lower saddle up glider legs, clamping electric cable into place (*diagram 8F*).

#### Electric Cable/Air Hose with Festoon Trolleys

Loosen nuts and clamp-plate enough to thread electric cable/air hose between the U-bolt legs and clamp plate on festoon trolley. Secure cable by tightening nuts on festoon trolley, forcing clamp plate snug against electric cable/air hose (*diagram 8G*).

**Note:** Be careful not to tighten bolts too tight; will cause damage to electric cable/air hose.

**Note:** Be sure that U-bolt does not interfere with trolley body.

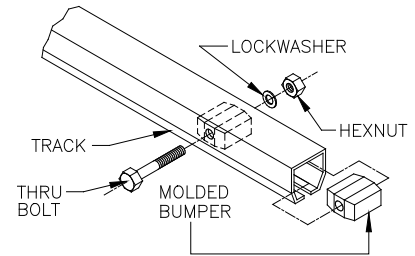

**Diagram 8E.** Installing end stops in bridge.

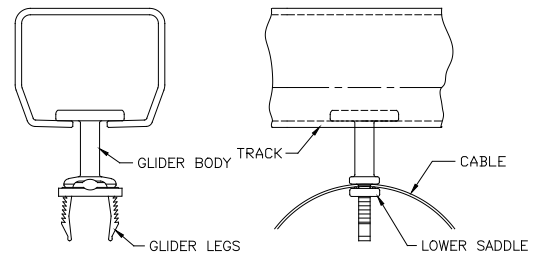

**Diagram 8F.** Installing electric cable on festoon glider.

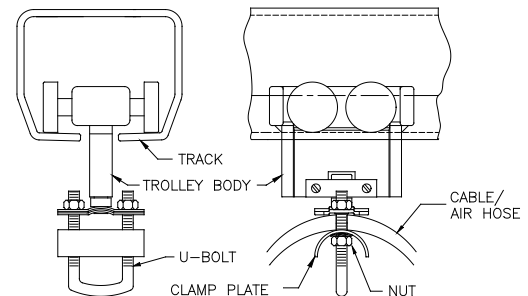

**Diagram 8G.** Installing electric cable or air hose on festoon trolley.

**IMPORTANT:** Cable/Air Hose Installation: It is important that as much twist as possible be taken out of the cable or hose before it is hung. To take the twist out follow the steps below:

1. Lay the cable or hose out on the floor flat.
2. Mark the cable or hose where the first end clamp will be and then make marks for trolley and bridge end clamp locations at 6-7 foot intervals. If cable or hose twist still exists, increase intervals.
3. Recoil the cable or hose so that the marks are all lined up on the top of the coiled cable or hose.
4. Lay the large coil on the floor with the marks lined up. At each mark, attach a trolley or end clamp. When installing the festoon, pick up the whole coil and run the trolleys in without disturbing the coil.

**Suggestion:** Air Swivels should be used at either end of cable or hose to reduce twist.

## STEP 8 - FESTOONING INSTALLATION (CONTINUED)

### Vacuum Hose Trolleys

Place strap around vacuum hose (by others). Secure Velcro sides together and be sure vacuum hose is held snugly in place (**diagram 8H**).

Clip vacuum hose hook (with vacuum hose attached) onto vacuum hose trolley (**diagram 8H**).

**Note:** Strap will fit vacuum hoses with outside diameters ranging from 1-1/2" to 2-3/4".

Clip vacuum hose hook (with vacuum hose attached) onto vacuum hose trolley (**diagram 8F**, page 12).

**Note:** If Velcro strap does not hold vacuum hose securely, engage vacuum device so a vacuum is present in the hose and retighten Velcro straps so the vacuum hose is held tightly.

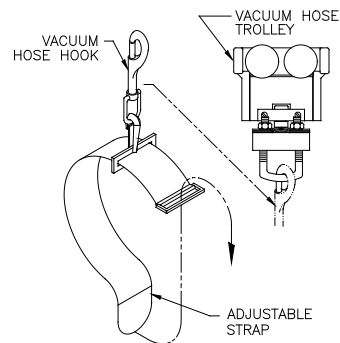
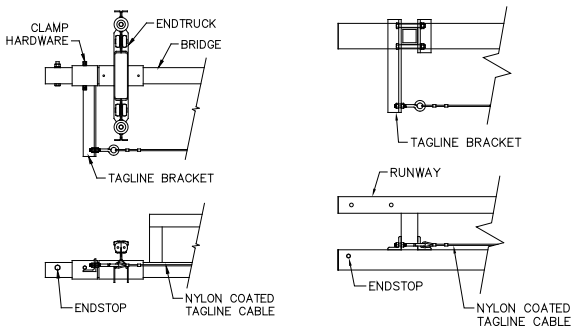

**Diagram 8H.** Installing vacuum hose on vacuum hose trolley.

## STEP 9 - BRIDGE AND RUNWAY TAGLINE INSTALLATION

**9.1** Slide tagline brackets onto each end of bridge and/or runway and tighten clamp hardware (**diagrams 9A** and **9B**).

**Note:** This will require removal of endstop hardware. This hardware must be re-installed immediately after tagline bracket is installed.



**Diagram 9A.** Tagline on bridge.

**Diagram 9B.** Tagline on runway.

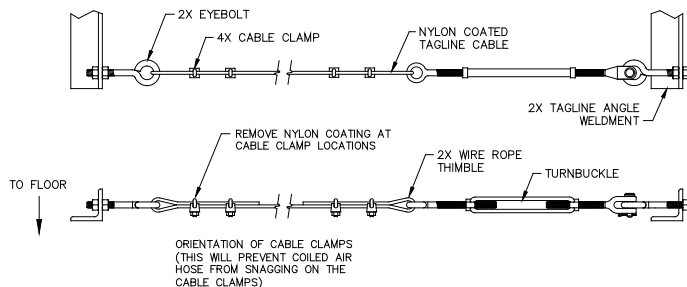
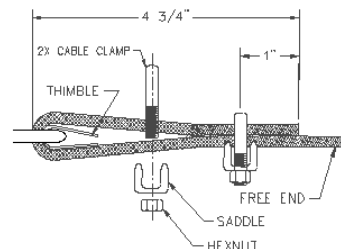

**Diagram 9C.** Tagline cable assembly.

**9.2** Attach eyebolts onto tagline brackets. Attach turnbuckle to one eyebolt. Loop cable through eyebolt or turnbuckle and turn back 4-3/4" of cable on a thimble. Apply first clamp 1" from the dead end of the cable and tighten U-bolt to 15 ft.-lbs. of torque. Apply the second clamp as close to thimble as possible. Tighten U-bolt to 15 ft.-lbs. of torque (**diagram 9D**).

**9.3** Add any S-hooks, wire rope trolleys, or coiled air hose to the cable prior to attaching the other end.

**9.4** Secure other end of the cable as in Step 9.2.

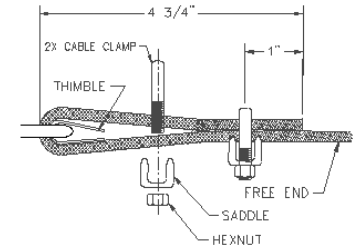

**Diagram 9D.** Saddling the cable on one end.

## STEP 10 - OPTIONAL ACCESSORIES

### Safety Cable Installation

- The safety cable is provided as a single piece and must be cut in the field as necessary. Each connection requires 5 ft. of cable.
- After cutting the cable down to required length, one end of each cable must be properly saddled using the thimble and U-bolt cable clamps provided (**diagram 10A**).
- Turn back 4-3/4" of cable on a thimble or loop. Apply the first clamp 1" from the dead end of the cable and tighten U-bolt to 15 ft.-lbs. of torque. Apply the second clamp as close to thimble or loop as possible. Tighten U-bolt to 15 ft.-lbs. of torque (**diagram 10A**).
- Pass the free end of cable through support points of each connection in which safety cabling is required.
- After the free end of cable has passed through all required support points, it should be passed through the saddled end of cable.
- Saddle the free end of cable while making sure both ends are interlocked. Complete the connection using the instructions from Step C above (**diagram 10B**).



**Diagram 10A.** Saddling the cable on one end.

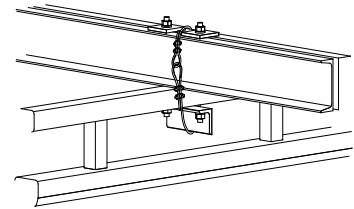

**Diagram 10B.** Safety cable installed on free standing header connection.

### WARNING

The cable and termination should be inspected periodically for wear, abuse, and general adequacy.

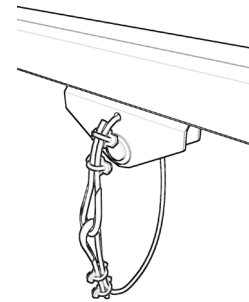

**Diagram 10C.** Safety cable installed on CM® LodeRail trolley that will attach to hoist (by others).

### Double Wired Endstop Installation

- Install end stop bumper with hardware provided (**diagram 10D**).
- Install additional hardware with bolt facing the same direction as the end stop hardware.
- Insert safety wire through the holes in each end stop bolt and twist ends together to secure wire in place (**diagram 10E**).

### WARNING

End stop bumper must be placed on the "inside" bolt so that the endtruck or trolley contacts the bumper and not the secondary bolt.

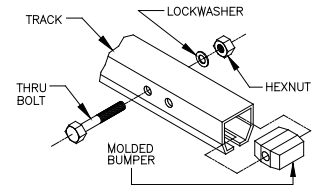

**Diagram 10D.** Installing endstop.

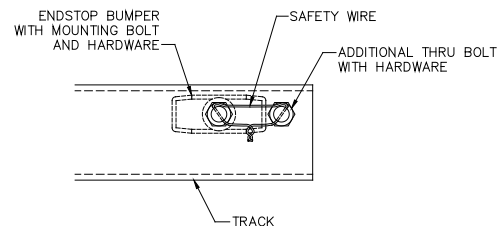
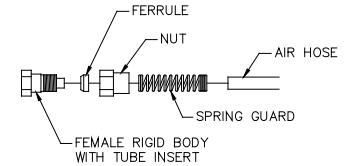

**Diagram 10E.** Double wired end stop.

## STEP 10 - OPTIONAL ACCESSORIES (CONTINUED)

### Coiled Air Hose Installation

- A) Assemble female fittings to the coiled air hose according to **diagram 10F**. The coiled air hose is inserted through the spring guard, nut, ferrule, and over the tube insert as far as possible. Note the orientation of the ferrule: the bevel is pointing towards the female fitting.
- B) Assemble the remainder of the components per **diagram 10G**.



**Diagram 10F.** Female fitting assembly.

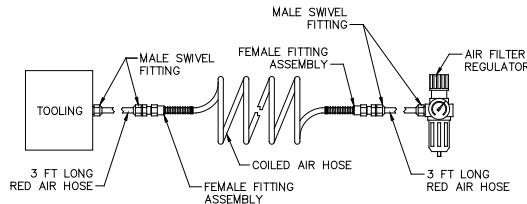

**Diagram 10G.** Coiled air hose assembly.

## STEP 11 - FINAL STEPS

**TIP:** Do not throw away this manual: the maintenance schedule is on the back cover.

- 11.1 Be sure all endstops are installed.
- 11.2 Check to make sure all bolts are tight and lockwashers are compressed.
- 11.3 If necessary, touch up crane with paint provided.
- 11.4 Install yellow rubber tracdoms on open ends of steel track.
- 11.5 Keep Packing List, Installation Manual, General Arrangement Drawing, and any other inserts filed together in a safe place.

## SWAY BRACING INSTRUCTIONS (OPTIONAL)

Support assemblies are designed to AISC (American Institute of Steel Construction) specifications. If reduced movement of the support assemblies is desired, then sway bracing (not included) can be added. The installer or end user must determine the possible locations of the bracing based on the specific application.

Bracing can be added in one of three formats, or a combination of any three.

- A) The most typical place to brace is directly to a building column. Providing a brace from a building column to the lateral (side) and longitudinal (lengthwise) axis of the support steel provides extreme rigidity throughout the system, and requires only minimal locations (2 or 3 corners of the system is typically adequate, see 'A' in **diagram 1**).
- B) Another method is to brace back to the ceiling above the crane. Again, bracing at the corners of the system in both a lateral and longitudinal direction is sufficient (see 'B' in **diagram 1**), providing the distance to the ceiling is not greater than 10 feet. For distances greater than 10 feet, additional points may need to be braced both laterally and longitudinally at the discretion of the end user and/or the installer.
- C) Finally, if the system is located at a point where it is not practical or possible to brace to the building columns or the ceiling structure, cross bracing can be done. This can be added at the sides of the system (see 'C' in **diagram 1**) to control longitudinal sway, or across the open ends to limit lateral motion (not shown). This can also be added to the top of the system, but should be checked to make sure that it does not interfere with the travel of the bridge.

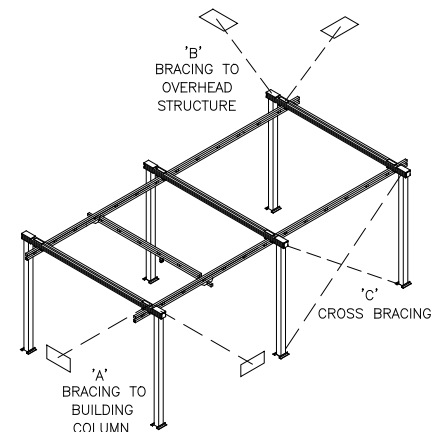

**Diagram 1.** Examples of typical sway bracing locations.

It should be noted that the use of sway bracing is purely subjective because it is not a requirement of CM® LodeRail. No specifications exist detailing appropriate methods, and the ultimate quantity and type is at the discretion of the user and installer. **If bracing, always determine if the building structure is adequate.**

# CRANE OPERATOR INSTRUCTIONS

Overhead cranes and jib cranes generally handle materials over working areas where there are personnel. Therefore, it is important for the Crane Operator to be instructed in the use of the crane and to understand the severe consequences of careless operation. It is not intended that these suggestions take precedence over existing plant safety rules and regulations or OSHA regulations. However, a thorough study of the following information should provide a better understanding of safe operation and afford a greater margin of safety for people and machinery on the plant floor. It must be recognized that these are suggestions for the Crane Operator's use. It is the responsibility of the owner to make personnel aware of all federal, state and local rules and codes, and to make certain operators are properly trained.

## Qualifications

Crane operation, to be safe and efficient, requires skill: the exercise of extreme care and good judgment, alertness and concentration, and rigid adherence to proven safety rules and practices as outlined in applicable and current ANSI and OSHA safety standards. In general practice, no person should be permitted to operate a crane:

- Who cannot speak the appropriate language or read and understand the printed instructions.
- Who is not of legal age to operate this type of equipment.
- Whose hearing or eyesight is impaired (unless suitably corrected with good depth perception).
- Who may be suffering from heart or other ailments which might interfere with the operator's safe performance.
- Unless the operator has carefully read and studied this operation manual.
- Unless the operator has been properly instructed.
- Unless the operator has demonstrated his instructions through practical operation.
- Unless the operator is familiar with hitching equipment and safe hitching equipment practices.

## Handling the Bridge Travel Motion

Before using the bridge of the crane, the operator should be sure the hook is high enough to clear any obstructions. Before a load is handled by the crane, the bridge should be brought into position so that it is directly over the load. Start the bridge slowly and bring it up to speed gradually. Approaching the place where it is desired to stop the bridge, reduce the bridge speed.

## Handling the Trolley Motion

Before a load is handled, the hoist should be positioned directly over the load that is to be handled. When the slack is taken out of the slings, if the hoist is not directly over the load, bring it directly over the load before hoisting is continued. Failure to center the hoist over the load may cause the load to swing upon lifting. Always start the trolley motion slowly and reduce the trolley speed gradually.

## Handling the Hoist Motion

Refer to the lifting (hoist) equipment's operating instructions.

# GENERAL SUGGESTIONS

## Know Your Crane

Crane operators should be familiar with the principal parts of a crane and have a thorough knowledge of crane control functions and movements. The crane operator should be required to know the location and proper operation of the main conductor disconnecting means for all power to the attachments on the crane.

## Responsibility

Each crane operator should be held directly responsible for the safe operation of the crane. Whenever there is any doubt as to SAFETY, the crane operator should stop the crane and refuse to handle loads until: (1) safety has been assured or (2) the operator has been ordered to proceed by the supervisor, who then assumes all responsibility for the SAFETY of the lift.

Do not permit **ANYONE** to ride on the hook or a load.

## Inspection

Test the crane movement and any attachments on the crane at the beginning of each shift. Whenever the operator finds anything wrong or apparently wrong, the problem should be reported immediately to the proper supervisor and appropriate corrective action taken.

## Operating Suggestions

One measure of a good crane operator is the smoothness of the crane operation. The good crane operator should know and follow these proven suggestions for safe, efficient crane handling.

1. The crane should be moved smoothly and gradually to avoid abrupt, jerky movements of the load. Slack must be removed from the sling and hoisting ropes before the load is lifted.
2. Center the crane over the load before starting the hoist to avoid swinging the load as the lift is started. Loads should not be swung by the crane to reach areas not under the crane.
3. Crane-hoisting ropes should be kept vertical. Cranes shall not be used for side pulls.
4. Be sure everyone in the immediate area is clear of the load and aware that a load is being moved.
5. Do not make lifts beyond the rated load capacity of the crane, sling chains, rope slings, etc.
6. Make certain that before moving the load, load slings, load chains, or other lifting devices are fully seated in the saddle of the hook with hook latch closed (if equipped with hook latch).
7. Check to be sure that the load and/or bottom block is lifted high enough to clear all obstructions when moving boom or trolley.
8. At no time should a load be left suspended from the crane unless the operator has the push button with the power on, and under this condition keep the load as close as possible to the floor to minimize the possibility of an injury if the load should drop. When the crane is holding a load, the crane operator should remain at the push button.
9. Do not lift loads with sling hooks hanging loose. If all sling hooks are not needed, they should be properly stored, or use a different sling.
10. All slings or cables should be removed from the crane hooks when not in use (dangling cables or hooks hung in sling rings can inadvertently snag other objects when the crane is moving).
11. Operators shall not carry loads and/or empty bottom blocks over personnel. Particular additional caution should be practiced when using magnet or vacuum devices. Loads, or parts of loads, held magnetically could drop. Failure of power to magnets or vacuum devices can result in dropping the load. Extra precaution should be exercised when handling molten metal in the proximity of personnel.
12. Whenever the operator leaves the crane the following procedure should be followed:
  - Raise all hooks to an intermediate position.
  - Spot the crane at an approved designated location.
  - Place all controls in the "off" position.
  - Open the main switch to the "off" position.
  - Make visual check before leaving the crane.
13. In case of emergency or during inspection, repairing, cleaning or lubrication, a warning sign or signal should be displayed and the main switch should be locked in the "off" position. This should be done whether the work is being done by the crane operator or by others.
14. Contact with rotation stops or trolley end stops shall be made with extreme caution. The operator should do so with particular care for the safety of the persons below the crane, and only after making certain that any persons on the other cranes are aware of what is being done.
15. ANY SAFETY FEATURES AND MECHANISMS BUILT-IN OR OTHERWISE PROVIDED WITH THE CRANE BY CM® LODERAIL ARE REQUIRED FOR THE SAFE OPERATION OF THE CRANE. DO NOT, UNDER ANY CIRCUMSTANCES, REMOVE OR OTHERWISE IMPAIR OR DISABLE THE PROPER FUNCTIONING OF ANY CRANE SAFETY MECHANISMS OR FEATURES BUILT-IN OR OTHERWISE PROVIDED BY CM® LODERAIL FOR SAFE OPERATION OF THE CRANE. ANY REMOVAL, IMPAIRMENT OR DISABLING OF ANY SUCH SAFETY MECHANISMS OR FEATURES OR OTHER USE OR OPERATION OF THE CRANE WITHOUT THE COMPLETE AND PROPER FUNCTIONING OF ANY SUCH SAFETY MECHANISMS OR FEATURES AUTOMATICALLY AND IMMEDIATELY VOIDS ANY AND ALL EXPRESS AND IMPLIED WARRANTIES OF ANY KIND OR NATURE.

## LIMITED WARRANTY

It is agreed that the equipment purchased hereunder is subject to the following LIMITED warranty and no other. Columbus McKinnon Corporation ("CM® LodeRail") warrants the manual push-pull Work Station Cranes and Jib Crane products to be free from defects in material or workmanship for a period of five years or 10,000 hours use from date of shipment. CM® LodeRail warrants the Motorized Work Station Crane products to be free from defects in material or workmanship for a period of two years or 4,000 hours use from the date of shipment. This warranty shall not cover failure or defective operation caused by operation in excess of recommended capacities, misuses, negligence or accident, and alteration or repair not authorized by CM® Loderail. No system shall be modified after manufacture without the written authorization of CM® LodeRail. Any field modification made to the system without the written authorization of CM® LodeRail shall void CM® LodeRail's warranty obligation. OTHER THAN AS SET FORTH HEREIN, NO OTHER EXPRESS WARRANTIES, AND NO IMPLIED WARRANTIES, ORAL OR WRITTEN, INCLUDING BUT NOT LIMITED TO THE WARRANTIES OF MERCHANTABILITY OR FITNESS FOR A PARTICULAR PURPOSE, ARE MADE BY CM® LODERAIL WITH RESPECT TO ITS PRODUCTS AND ALL SUCH WARRANTIES ARE HEREBY SPECIFICALLY DISCLAIMED. CM® LODERAIL SHALL NOT BE LIABLE UNDER ANY CIRCUMSTANCES FOR ANY INCIDENTAL, SPECIAL AND/OR CONSEQUENTIAL DAMAGES WHATSOEVER, WHETHER OR NOT FORESEEABLE, INCLUDING BUT NOT LIMITED TO DAMAGES FOR LOST PROFITS AND ALL SUCH INCIDENTAL, SPECIAL AND/OR CONSEQUENTIAL DAMAGES ARE HEREBY ALSO SPECIFICALLY DISCLAIMED. CM® LodeRail's obligation and Purchaser's or end user's sole remedy under this warranty is limited to the replacement or repair of CM® LodeRail's products at the factory, or at the discretion of CM® LodeRail, at a location designated by CM® LodeRail. Purchaser or end user shall be solely responsible for all freight and transportation costs incurred in connection with any warranty work provided by CM® LodeRail hereunder. CM® LodeRail will not be liable for any loss, injury or damage to persons or property, nor for damages of any kind resulting from failure or defective operation of any materials or equipment furnished hereunder. Components and accessories not manufactured by CM® LodeRail are not included in this warranty. Purchaser's or end user's remedy for components and accessories not manufactured by CM® LodeRail is limited to and determined by the terms and conditions of the warranty provided by the respective manufacturers of such components and accessories.

**A) DISCLAIMER OF IMPLIED WARRANTY OF MERCHANTABILITY**

CM® LodeRail and Purchaser agree that the implied warranty of merchantability is excluded from this transaction and shall not apply to the goods involved in this transaction.

**B) DISCLAIMER OF IMPLIED WARRANTY OF FITNESS FOR PARTICULAR PURPOSE**

CM® LodeRail and Purchaser agree that the implied warranty of fitness for particular purpose is excluded from this transaction and shall not apply to the goods involved in this transaction.

**C) DISCLAIMER OF EXPRESS WARRANTY**

CM® LodeRail's agents, or dealer's agents, or distributor's agents may have made oral statements about the machinery and equipment described in this transaction. Such statements do not constitute warranties, and Purchaser agrees not to rely on such statements. Purchaser also agrees that such statements are not part of this transaction.

**D) DISCLAIMER OF SPECIAL, INCIDENTAL AND CONSEQUENTIAL DAMAGES**

CM® LodeRail and Purchaser agree that any claim made by Purchaser which is inconsistent with CM® LodeRail's obligations and the warranty remedies provided with CM® LodeRail's products, and in particular, special, incidental and consequential damages, are expressly excluded.

**E) DEALER OR DISTRIBUTOR NOT AN AGENT**

CM® LodeRail and Purchaser agree that Purchaser has been put on notice that dealer or distributor is not CM® LodeRail's agent in any respect for any reason. CM® LodeRail and Purchaser also agree that Purchaser has been put on notice that dealer or distributor is not authorized to incur any obligations or to make any representations or warranties on CM® LodeRail's behalf other than those specifically set forth in CM® LodeRail's warranty provided in connection with its product.

**F) MERGER**

This warranty agreement constitutes a final and complete written expression of all the terms and conditions of this warranty and is a complete and exclusive statement of those terms.

**G) PAINTING**

Every crane (excluding components) receives a quality paint job before leaving the factory. Unfortunately, no paint will protect against the abuses received during the transportation process via common carrier. We have included at least one (1) twelve ounce spray can for touchup with each crane ordered (unless special paint was specified). If additional paint is required, contact a CM® LodeRail Customer Service Representative at 1-800-888-0985 or 1-716-689-5400

**Title and Ownership:**

Title to the machinery and equipment described in the foregoing proposal shall remain with CM® LodeRail and shall not pass to the Purchaser until the full amount herein agreed to be paid has been fully paid in cash.

**Claims and Damages:**

Unless expressly stated in writing, goods and equipment shall be at Purchaser's risk on and after Seller's delivery in good shipping order to the Carrier. CM® LodeRail shall in no event be held responsible for materials furnished or work performed by any person other than it or its authorized representative or agent.

**Cancellations:**

If it becomes necessary for the purchaser to cancel this order wholly or in part, he shall at once so advise CM® LodeRail in writing. Upon receipt of such written notice all work will stop immediately. If the order entails only stock items, a flat restocking charge of 15% of the purchase price will become due and payable by Purchaser to CM® LodeRail. Items purchased specifically for the canceled order shall be charged for in accordance with the cancellation charges of our supplier plus 15% for handling in our factory. The cost of material and/or labor expended in general fabrication for the order shall be charged for on the basis of total costs to CM® LodeRail up to the time of cancellation plus 15%.

**Returns:**

No equipment, materials or parts may be returned to CM® LodeRail without express permission in writing to do so.

Extra Charge Delay: If Purchaser delays or interrupts progress of Seller's performance, or causes changes to be made, Purchaser agrees to reimburse CM® LodeRail for expense, if any, incident to such delay.

**Changes and Alterations:**

CM® LodeRail reserves the right to make changes in the details of construction of the equipment, as in its judgment, will be in the interest of the Purchaser; will make any changes in or additions to the equipment which may be agreed upon in writing by the Purchaser; and CM® LodeRail is not obligated to make such changes in products previously sold any customer.

**Third Party Action:**

Should CM® LodeRail have to resort to third party action to collect any amount due after there (30) days from date of invoice, the Purchaser agrees to pay collection costs, reasonable attorney's fees, court costs and legal interest.

**OSHA Responsibilities:**

CM® LodeRail agrees to fully cooperate with Purchaser in the design, manufacture or procurement of safety features or devices that comply with OSHA regulations. In the event additional equipment or labor shall be furnished by CM® LodeRail, it will be at prices and standard rates then in effect, or as may be mutually agreed upon at the time of the additional installation.

**Equal Employment Opportunity:**

CM® LodeRail agrees to take affirmative action to ensure equal employment opportunity for all job applicants and employees without regard to race, color, age, religion, sex, national origin, handicap, veteran, or marital status. CM® LodeRail agrees to maintain non-segregated work facilities and comply to rules and regulations of the Secretary of Labor or as otherwise provided by law or Executive Order.

# INSPECTION AND MAINTENANCE SCHEDULE

CM® LODERAIL WORK STATION CRANE: INSPECTION AND MAINTENANCE SCHEDULE			
ITEM	COMPONENT	MAINTENANCE	FREQUENCY*
1	Header Clamp Plate Hardware	Check for full compression of lockwasher. Bolt should be tightened to manufacturer's specifications.	Every 2,000 hours or yearly
2	Spine Clamp Hardware	Check for full compression of lockwasher. Bolt should be tightened to manufacturer's specifications.	Every 2,000 hours or yearly
3	Truss Splice Plate	Check for full compression of lockwasher. Bolt should be tightened to manufacturer's specifications.	Every 2,000 hours or yearly
4	Splice Joint	All bolts should be in contact with track. Check track for alignment and that wheel rolling surface is flush.	Every 2,000 hours or yearly
5	Hoist Trolley	Check clevis pin. Check cotter pin. (Cotter pin should be fully wrapped around clevis pin.) Check clevis bolt and hardware.	Every 2,000 hours or yearly
6	End Stops (both runway and bridge)	Check for full compression of lockwasher. If thru bolt is exposed, replace endstops.	Every 2,000 hours or yearly
7	Festoon Cable Clamp or Vacuum Hoist Clamp	Check for full compression of lockwasher.	Every 2,000 hours or yearly
8	Wheels	Check for cracks, puts, and/or grooves: all of these increase pull forces. If any of these conditions exist, wheels should be replaced.	Every 2,000 hours or yearly
9	Aluminum Bridge Assembly Hardware	Check that lockwashers are compressed and nuts tightened to torque specifications (chart 3A, page 3). Ensure sheer lug hardware is in required position and tight.	Every 2,000 hours or yearly
10	End Trucks	Check for proper clamping hardware attachment. Ensure correct position on bridge to match specified cantilevers. Inspect end truck wheels following instructions for wheels above. <u>Standard end truck:</u> Make sure body is free of any bent materials, cracked or broken welds. <u>Extended end truck:</u> Check overall condition of tubes. Examine supports for bent materials, cracked or broken welds. Inspect hardware attaching end truck support to tubes. Check wheel plate attachment bolts for any wear and make sure the nylock nut is still in the correct position.	Every 2,000 hours or yearly

\*Federal, state and local codes may require inspection and maintenance checks more often. Please check the federal, state and local code manuals in your area.

## WARNING

Any changes in rolling effort or unusual noises must be immediately identified and corrected. It is not necessary to lubricate the track or bearings. Lubricating may attract airborne particles and may increase the rolling resistance. (Do not use such substances as WD-40®, silicone sprays, oil or grease on bearings or on track flanges.)

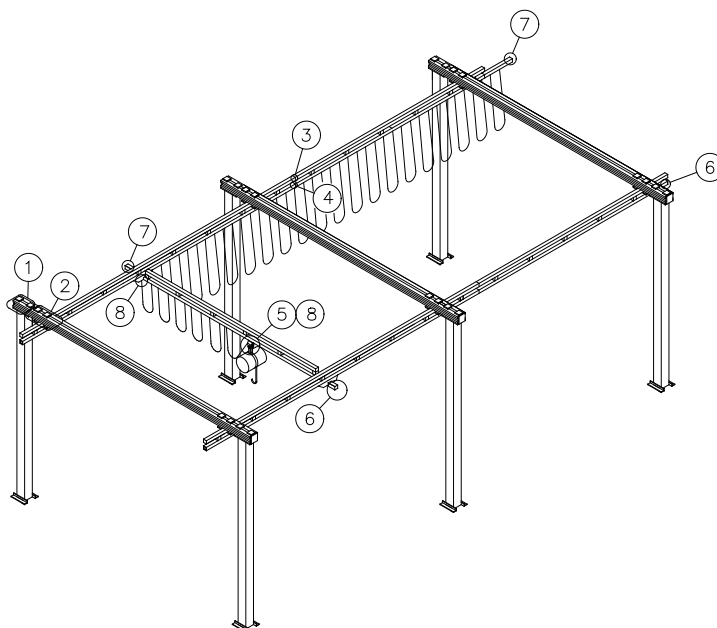

U.S. Patent No: US05694857  
U.S. Patent No: US05443151



**LodeRail**

140 John James Audubon Pkwy.  
Amherst, NY 14228-1197  
Phone: (800) 888-0985  
Fax: (716) 689-5514  
E-Mail: sales@cmworks.com  
<http://www.cmworks.com>

© 2011 Columbus McKinnon Corp.  
All Rights Reserved