

APPLICATION EVALUATION — SHEET LIFTERS

BUNDLE INFORMATION:

Bundle Dimensions:

Minimum: Length _____ Width _____ Height _____ Weight _____

Maximum: Length _____ Width _____ Height _____ Weight _____

Specify material being lifted: _____

Is the bundle palletized? Yes No If yes, specify pallet size: _____

Sheet Condition: Dry Oily Banded Loose

ADDITIONAL INFORMATION:

Please provide the model and/or serial number if this is to replace an existing CM Cady lifter: _____

Operation Required Motorized Manual

If motorized, please specify DC AC Voltage _____ Phase _____ Cycle _____

Pendant Required Yes No

Should the controls be shipped loose for field mounting? Yes No

Please provide duty cycle of lifter (lifts per hour and hours per day used): _____

Please provide Crane Classification (A, B, C, D, E, F): _____

Please use the space below to provide additional application information or options required.

For example: headroom issues, space restrictions, lifter restrictions or options such as a chainwheel or end chains.

Contact: _____

Company: _____

Address: _____

City, State, Zip: _____

Phone: _____

Fax: _____

Email: _____

CRANE HOOK DATA:

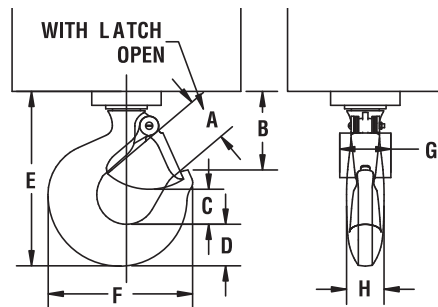

INCHES

- A _____ +0
- B _____ +0
- C _____ +0
- D _____ -0
- E _____ -0
- F _____ +/-
- G _____ -0
- H _____ -0

Measurement Tolerances

- +0 = Measurement should be no larger but can be smaller than actual.
- 0 = Measurement should be no smaller but can be larger than actual.
- +/- = Measurement can be larger or smaller than actual.

For a price quote on your specific application, please complete this above form and fax to 1 (716) 689.5582 or you can complete this form online at www.cmworks.com/cady