

## OVERVIEW OF LIFTING TONGS

CM Cady Lifting Tongs are available in standard configurations to fit many common applications. However, not all lifting challenges will be solved with a standard tong. CM Cady has the experienced team that can create a custom designed lifting tong to fit the specifications provided. All custom CM Cady Lifting tongs are designed to comply with ASME standards.



### FRICTION TONGS

Grab arms conform to load surface with outside diameter supported below center of load for additional holding advantage. Designed to lift such products as rolls, tubes, and other cylindrical materials.



### INDENTATION TONGS

Grab arms grip vertical sides of straight sided materials. Custom grip pads are required to have sufficient coefficient of friction between material lifted and grip pads. Grip pads may be rubber, steel, belting, points and other. Designed to lift such products as bales, boxes, ingots, and other straight sided materials.

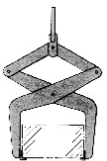

### SUPPORTING TONGS

Grab arms have feet to support underneath load. Designed to handle constant sizes of material to maintain a horizontal plane on the lifting feet. Dunnage under material required to insert/remove feet of tong. Designed to lift constant sized boxes, containers, crates, and other constant sized square shaped material.



## CUSTOM FRICTION TONGS

### APPLICATION IDEAS FOR CUSTOM FRICTION TONGS TO LIFT ROLLS, TUBES AND CYLINDRICAL MATERIALS

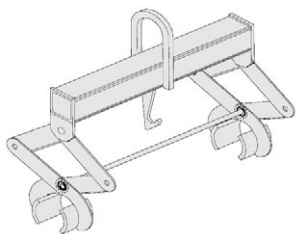

The **Dual Gripping Tong** system supports and stabilizes longer, larger loads. The large contoured pads distribute the force applied to the load over a larger surface area. Optional pad linings, nylon or rubber pads protect the load from damage. This is ideal when handling rolls of fabric or polyethylene film.

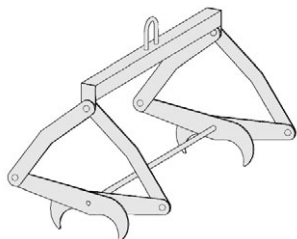

This **Dual Gripping Tong** system will support and stabilize longer, larger loads that can sustain the force of the entire load on a smaller surface area. When the narrow gripping arms engage the item, significant pressure will be applied. Ideal for handling bundles of steel that are round in shape.

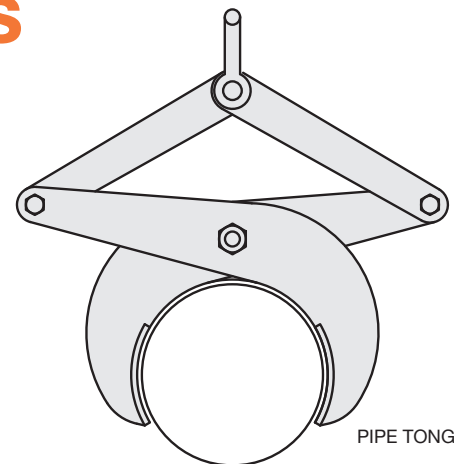

PIPE TONGS

The **Single Gripping Tong** is used to lift cylindrical objects that are short in length such as large diameter round bar, tube or rolls of material.

We have integrated both a manual latch or the Auto-Latch mechanism into this family of tongs. The selection of the latch is dependant on the application.