

Heavy-duty 8-bar system

8-bar is the most economical solution for electrifying cranes and monorails. For systems requiring higher amperage, greater number of conductors and/or longer run, contact CM.

- 3 inch spacing between conductors
- 10 foot sections
- Conductor bar lengths can be field cut to length with hand saw
- Standard CM conductor bar kits (for straight runs only)
- Custom-engineered systems available
- Mounting staffs on new applications are required
- Made in U.S.A.

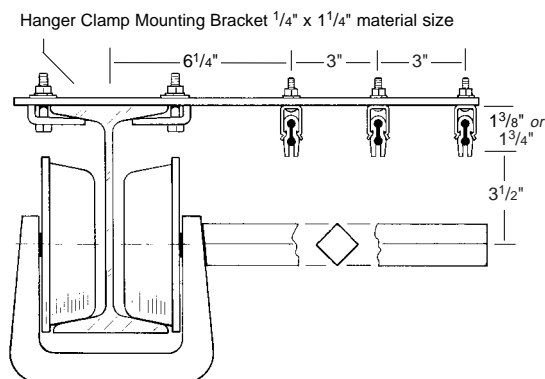

3 Conductor, 110 amp (maximum) system selection chart

Product code	System length (ft.)	Conductor bar 11000	Power feed 11091	End cover 11088	Collector 30 amp 13128	Anchor clamp 21833	Hanger clamp 31400	Support bracket 31418
C1020	50	15	3	6	3	3	27	10
C1021	60	18	3	6	3	3	33	12
C1022	70	21	3	6	3	3	39	14
C1023	80	24	3	6	3	3	45	16
C1024	90	27	3	6	3	3	51	18
C1025	100	30	3	6	3	3	57	20
C1026	110	33	3	6	3	3	63	22
C1027	120	36	3	6	3	3	69	24
C1028	130	39	3	6	3	3	75	26
C1029	140	42	3	6	3	3	81	28
C1030	150	45	3	6	3	3	87	30

4 Conductor, 110 amp (maximum) system selection chart

Product code	System length (ft.)	Conductor bar 11000	Power feed 11091	End cover 11088	Collector 30 amp 13128	Anchor clamp 21833	Hanger clamp 31400	Support bracket 31418
C1031	50	20	4	8	4	4	36	10
C1032	60	24	4	8	4	4	44	12
C1033	70	28	4	8	4	4	52	14
C1034	80	32	4	8	4	4	60	16
C1035	90	36	4	8	4	4	68	18
C1036	100	40	4	8	4	4	76	20
C1037	110	44	4	8	4	4	84	22
C1038	120	48	4	8	4	4	92	24
C1039	130	52	4	8	4	4	100	26
C1040	140	56	4	8	4	4	108	28
C1041	150	60	4	8	4	4	116	30

For monorail systems only one 8-bar kit is needed

One 8-bar kit is needed for each bridge

For multiple hoists, additional collectors are required (P/N 13128)

Connector tool included with each kit

*** ⚠ WARNING**

Improper handling and installation of electrical components can result in injury.

To avoid injury:

- Turn off power before installing components. Follow lockout/tagout procedure. Refer to ANSI Z244.1.
- Observe requirements of National Electrical Code ANSI/NFPA 70 and applicable state and local codes.