

Hoist Test Stand - 12 Ton Capacity

The Value - Priced, Hydraulic Hand Operated Test Stand — Tests Hoist Capacity to 12 Tons

The Value-Priced CM Test Stand is specially designed for the testing of hoisting equipment as required by the applicable sections of ASME Code B30.16. Unlike other test stands on the market that weigh thousands of pounds, the CM Value-Priced Test Stand weighs only 496 pounds. Portability for on-site testing becomes more practical. Fewer wearing parts provide superior performance.

- Hand operated hydraulic pump eliminates the need for electrical power.
- Capable of applying test loads up to 12 tons.
- Compact, self-contained design for portability and on-site testing.
- Eliminates the need for cumbersome test weights.
- Capable of both static and dynamic testing.
- Tests the function of overload devices.
- Rugged steel frame construction for strength and durability.
- High quality, high strength, hydraulic cylinder made from chromium-molybdenum steel, heat treated for long life and chrome plated for added protection.
- Two-stage, quick action hand pump for ease of operation.
- Fine adjustment pressure valve for accurate load testing.
- Large pressure gauge for easy reading.
- Made in USA

Technical data

Hydraulic Cylinder (hollow)

| | |
|-----------------------|--------------------------------|
| Type | • Single acting, spring return |
| Maximum pulling force | • 12 tons @ 5800 p.s.i. |
| Stroke | • 6 in. |
| System pressure | • 0 - 5800 p.s.i. |
| Center hole diameter | • .87 in. |

Hydraulic Hand Pump

| | |
|-----------------|--|
| System pressure | • 0 - 6090 p.s.i. |
| Reservoir | • 1.47 pints |
| Valve | • Two-stage, fine adjustment pressure preset |
| Gauge | • Glycerin filled - 3.94 in. dia. |

| | |
|--------------|--|
| Frame | • Mounting holes in base for permanent mount |
|--------------|--|

| | |
|---------------------|------------|
| Total Weight | • 496 lbs. |
|---------------------|------------|



12 Ton Test Stand
Product Code 1200

Hoist test stand

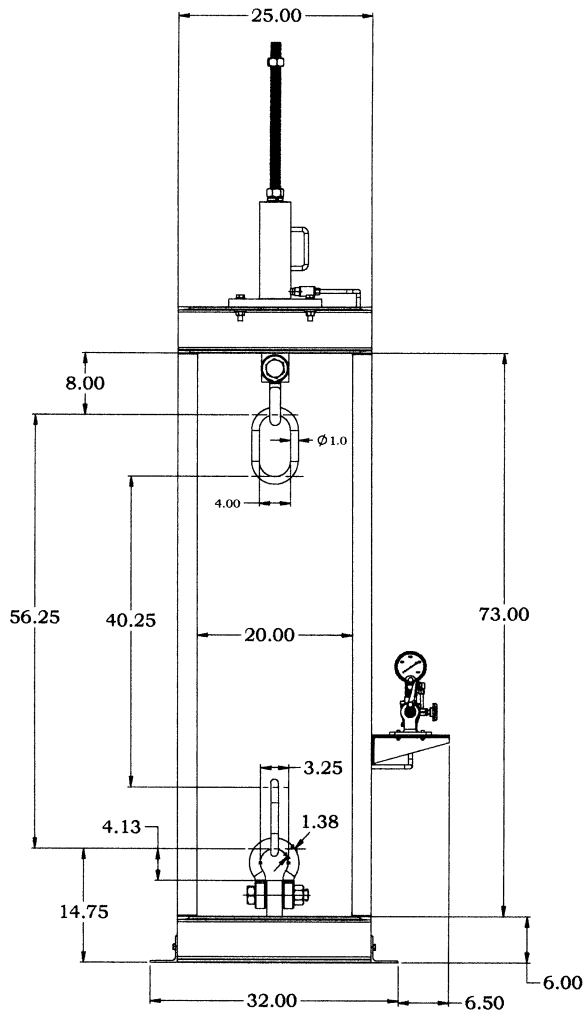

Front View

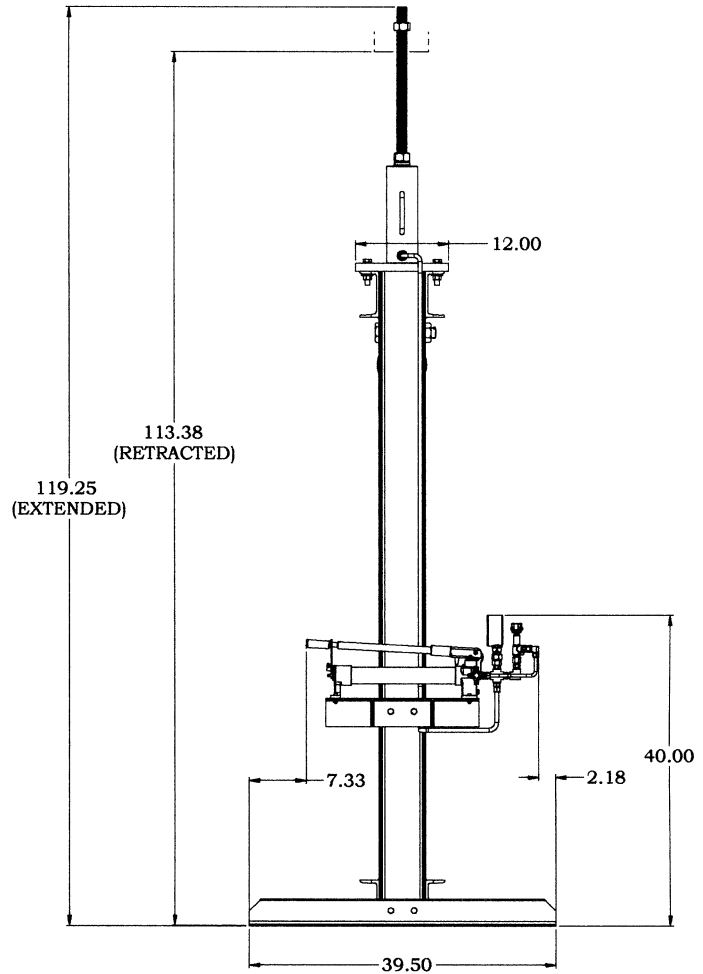

Side View

All Dimensions In Inches

WARNING

Overloading and improper use can result in injury.

To avoid injury:

- Do not exceed maximum pulling force of 12 tons
- Read and follow all instructions.