

CYCLONE LOW HEADROOM TROLLEY HOIST PARTS LIST

Key No.	No. Req'd.	Part Name	Capacity - Tons		
			1/2 & 1	1-1/2, 2 & 3	4, 5, & 6
			Part Number		
648-123A	1	Spider Bearing Retainer	—	45752	
648-123B	2	Spider Bearing Retainer Screw	—	987716	
648-124A	1	Gear Cover	—	45717	
648-124B	3	Gear Cover Screw	—	983732	
648-124C	1	Gear Cover Gasket	—	45746	
648-130	1	Load Chain (Specify Lift or Length Req'd.)	—	85864	
648-131	1	Hoist Hand Chain (Specify Lift or Length Req'd.)	—	85808	
648-145	1	Hand Chain Connecting Link	—	945490	
648-160	1	Front Frame with Pawl Stud and Pawl Spring Pin	—	48612	
648-160B	1	Pawl Spring Pin	—	983531	
648-160C	1	Pawl Stud Pin	—	983535	
648-160D	1	Pawl Stud	—	48376	
648-161A	4	Front Frame Screw	—	987020	
648-161B	5	Front Frame Screw L.W.	—	945851	
648-161C	1	Front Frame and Stripper Screw	—	948807	987034
648-162A	1	Trolley Frame (Specify if for Plain or Geared)	—	48668	48670
648-162B	1	Trolley Frame (Specify if for Plain or Geared)	—	48667 for 1 1/2, 2 & 3 ton plain trolley 46664 for 1 1/2, 2 & 3 ton geared trolley 48669 for 4, 5 & 6 ton plain trolley 46665 for 4, 5 & 6 ton geared trolley	
648-163A	2	Suspension Bolt	—	58503 (1" Dia. x 12 1/4" Long) for 1 1/2, 2 and 3 ton. 48372 (1 1/4" Dia. x 15" Long) for 4, 5 & 6 ton	
648-163B	4	Suspension Bolt Nut	—	958818	945835
648-163C	4	Suspension Bolt Cotter Pin	—	988368	988381
648-164	—	Spacer Washer (Specify Quantity)	—	958726	948701
648-165A	4	Trackwheel	—	58162	58163
648-165B	8	Trackwheel Bearing Cup	—	88521	88556
648-165C	8	Trackwheel Bearing Cone	—	88525	88545
648-165D	8	Trackwheel Bearing Seal Washer	—	68918	68917
648-166A	4	Trackwheel Stud	—	58459	58540
648-166B	4	Trackwheel Stud Nut	—	982613	988192
648-166C	4	Trackwheel Stud Collar	—	58484	58492
648-167	1	Gear Housing	—	48015	
648-168A	5	Gear Housing Screw	—	948806	948807
648-168B	5	Gear Housing Screw L.W.	—	945851	
648-169A	2	Trackwheel Gear	—	58548	58549
648-169B	4	Trackwheel Gear Pin	—	983503	
648-170	1	Trackwheel Pinion	—	46385	
648-171	1	Trackwheel Pinion Key	—	85446	
648-172	1	Trolley Handwheel	—	33143	
648-173	1	Trolley Handwheel Key	—	59967	
648-174A	1	Handwheel Bracket with Bushings	—	59616	
648-174B	2	Handwheel Bracket Bushing	—	58727	
648-175A	3	Handwheel Bracket Screw	—	987061	
648-175B	3	Handwheel Bracket Screw L.W.	—	945853	
648-176	1	Trolley Hand Chain Guide	—	58152	
648-177A	1	Trolley Hand Chain Guide Screw	—	987065	
648-177B	1	Trolley Hand Chain Guide Screw Nut	—	945822	
648-177C	1	Trolley Hand Chain Guide Screw L.W.	—	945853	
648-177D	1	Trolley Hand Chain Guide Screw Washer	—	986224	
648-178A	1	Trolley Handwheel Shaft	—	58504	
648-178B	2	Trolley Handwheel Shaft Nut	—	988095	
648-178C	2	Trolley Handwheel Shaft L.W.	—	986270	
648-179	1	Trolley Hand Chain (Specify Lift or Length Req'd.)	—	85808	
648-180	1	Hand Chain Connecting Link	—	945490	
648-230	1	Hanger Chain Anchor Pin (4 Ton)	—	—	45425
648-231	2	Hanger Chain Anchor Pin Retainer (4 Ton)	—	—	48024
648-232	2	Hanger Chain Anchor Pin Block (4 Ton)	—	—	48393
648-239	1	Upper Sheave (5 & 6 Ton)	—	—	45085
648-242	2	Upper Sheave Bearing (5 & 6 Ton)	—	—	83670
648-243	1	Hanger Snap Ring (4 Ton)	—	—	45765
648-243	1	Upper Sheave Bearing Snap Ring (5 & 6 Ton)	—	—	45765
648-244	2	Upper Sheave Bearing Retainer (5 & 6 Ton)	—	—	45151
648-260	1	Hanger Chain Anchor	—	48019 (3 Ton)	48021 (4 Ton)
648-261	1	Dead End Pin (3 & 4 Ton)	—	45945 (3 Ton)	45944 (4 Ton)
648-262	1	Liftwheel Gear	—	45062	
648-263	1	Intermediate Gear and Pinion	—	45080 for 1 1/2 & 3 ton, 45081 for 2, 4, 5 & 6 ton	

CYCLONE LOW HEADROOM TROLLEY HOIST PARTS LIST

Key No.	No. Req'd.	Part Name	Capacity - Ton		
			1/2 & 1	1-1/2, 2, 3	4, 5, & 6
			Part Number		
648-1	1	Main Frame	48001		
648-2A	1	Load Chain Guide	45047 (1/2 T.) 45048 (1T.)		
648-2B	2	Load Chain Guide Screw	982368		
648-2C	2	Load Chain Guide Screw L.W.	945851		
648-3A	1	Stripper	45043		
648-3B	2	Stripper Screw-Long	982709		
648-3C	3	Stripper Screw L.W.	Order 648-3B & 648-3D		
648-3D	1	Stripper Screw-Short	987315		
648-4A	1	Handwheel Shaft & Pinion	45357 (1/2 T.) 45358 (1T.)		
648-4B	1	Handwheel Shaft Bearing (Handwheel End)	88437		
648-4C	1	Handwheel Shaft Bearing (Gear End)	88444		
648-4D	1	Handwheel Shaft Snap Ring	45873		
648-14B	1	Cover Label			946754
648-15A	3	Handwheel Cover Screw	982698		
648-16A	1	Liftwheel	48362 (1/2 T.) 48368 (1 T.)		
648-16B	1	Liftwheel Bearing (Handwheel End)	88429		
648-16C	1	Liftwheel Bearing (Gear End)	83674		
648-16D	2	Liftwheel Snap Ring	48704		
648-17A	1	Frame Bearing Retainer	48702		
648-17B	2	Frame Bearing Retainer Screws	987716		
648-20	1	Liftwheel Shaft Nut	945841		
648-24B	3	Gear Cover Screw	987322		
648-30	1	Load Chain (Specify Lift or Length Req'd.)	85839 (1/2 T.) 85841 1 T.)		
648-31	1	Hand Chain (Specify Lift or Length Req'd.)	85808		
648-32	1	Warning Tube		946735	
648-33	1	I.D. Plate		45982	
648-34	2	Drive Screw		988271	
648-45	1	Hand Chain Connecting Link	945490		
648-60	1	Front Frame with Pawl Stud and Pawl Spring Pin	48611		
648-60B	1	Pawl Spring Pin	983531		
648-60C	1	Pawl Stud Pin	983494		
648-60D	1	Pawl Stud	48376		
648-61A	4	Front Frame Screw	987019		
648-61B	4	Front Frame Screw L.W.	945851		
648-62	2	Trolley Frame	*48005		
648-63A	2	Suspension Bolt	*48371		
648-63B	4	Suspension Bolt Nut	948803		
648-63C	4	Suspension Bolt Cotter Pin	988343		
648-64	-	Spacer Washer (Specify Quantity)	948700		
648-65	4	Trackwheel	*50762		
648-66A	4	Trackwheel Stud	*48300		
648-66B	4	Trackwheel Stud Nut	*948804		
648-66C	4	Trackwheel Stud Nut L.W.	*987924		
648-101	1	Main Frame		**48010 For 1-1/2 & 2 Ton, 48010 For 3 Ton, 48013 For 4, 5 & 6 Ton	
648-102A	1	Load Chain Guide		45049	
648-102B	3	Load Chain Guide Screw		948805	
648-102C	3	Load Chain Guide Screw L.W.		45852	
648-103A	1	Stripper		48043	
648-103B	1	Stripper Screw		87055	
648-103C	1	Stripper Screw L.W.		987919	
648-104A	1	Handwheel Shaft and Pinion		45360 (10 Teeth, 18-7/64 Long) For 1 1/2 & 3 Ton, 45359 (8 Teeth, 18-7/64 Long) for 2 Ton and 45361 (8 Teeth, 20-47/64 Long) for 4.5, & 6 Ton.	
648-104B	1	Handwheel Shaft Bearing (Handwheel End)		88437	
648-104C	1	Handwheel Shaft Bearing (Gear End)		83671	
648-112	2	Handwheel Shaft Nut		931717	
648-115A	3	Handwheel Cover Screw		982698	
648-116A	1	Liftwheel		48369	48370
648-116B	1	Liftwheel Bearing (Handwheel End)		83678	
648-116C	1	Liftwheel Bearing (Gear End)		83669	
648-116D	1	Liftwheel Snap Ring		45766	
648-117A	1	Frame Bearing Retainer		45751	
648-117B	2	Frame Bearing Retainer Screw		987716	
648-121D	1	Intermediate Gear and Pinion Nut		931717	
648-122A	1	Spider		45035	
648-122B	2	Spider Dowel		45430	
648-122C	3	Spider Attaching Screw		987319	
648-122D	3	Spider Attaching Screw L.W.		940830	

*Part numbers listed are for trolleys that operate on 6" thru 12" S-beams. If trolley operates on 4" or 5" S-beam, part numbers are as follows: 48006 for 648-62 trolley frame, 48373 for 648-63A suspension bolt, 54732 for 648-65 trackwheel, 54731 for 648-66A trackwheel stud, 982521 for 648-66B trackwheel stud nut and 987921 for 648-66C trackwheel stud nut lockwasher.

**Part number listed is for trolley that operates on 7" thru 15" S-beams. If trolley operates on 6" S-beam, part number is 48032 (1 1/2 & 2 Ton).

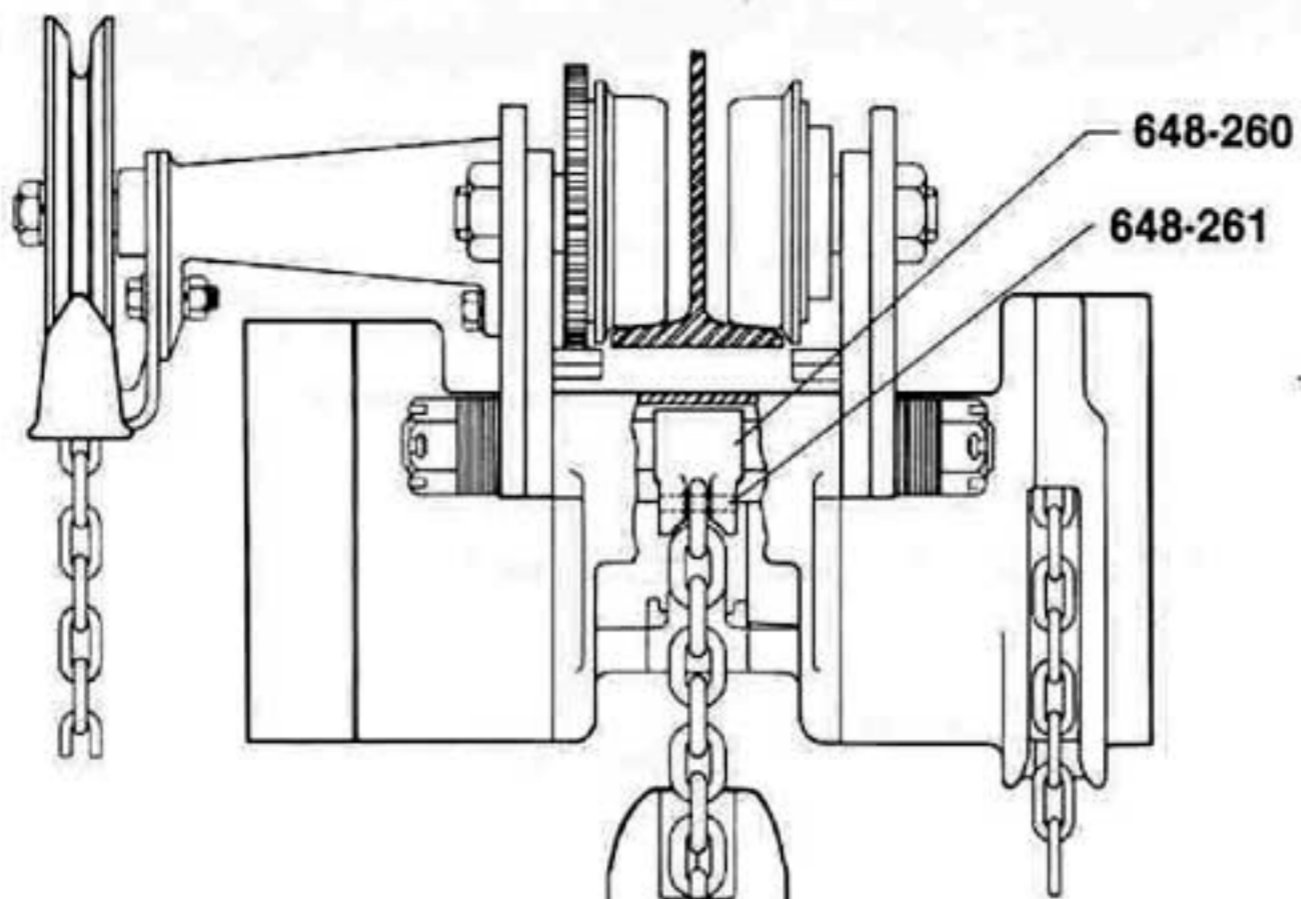

3 Ton

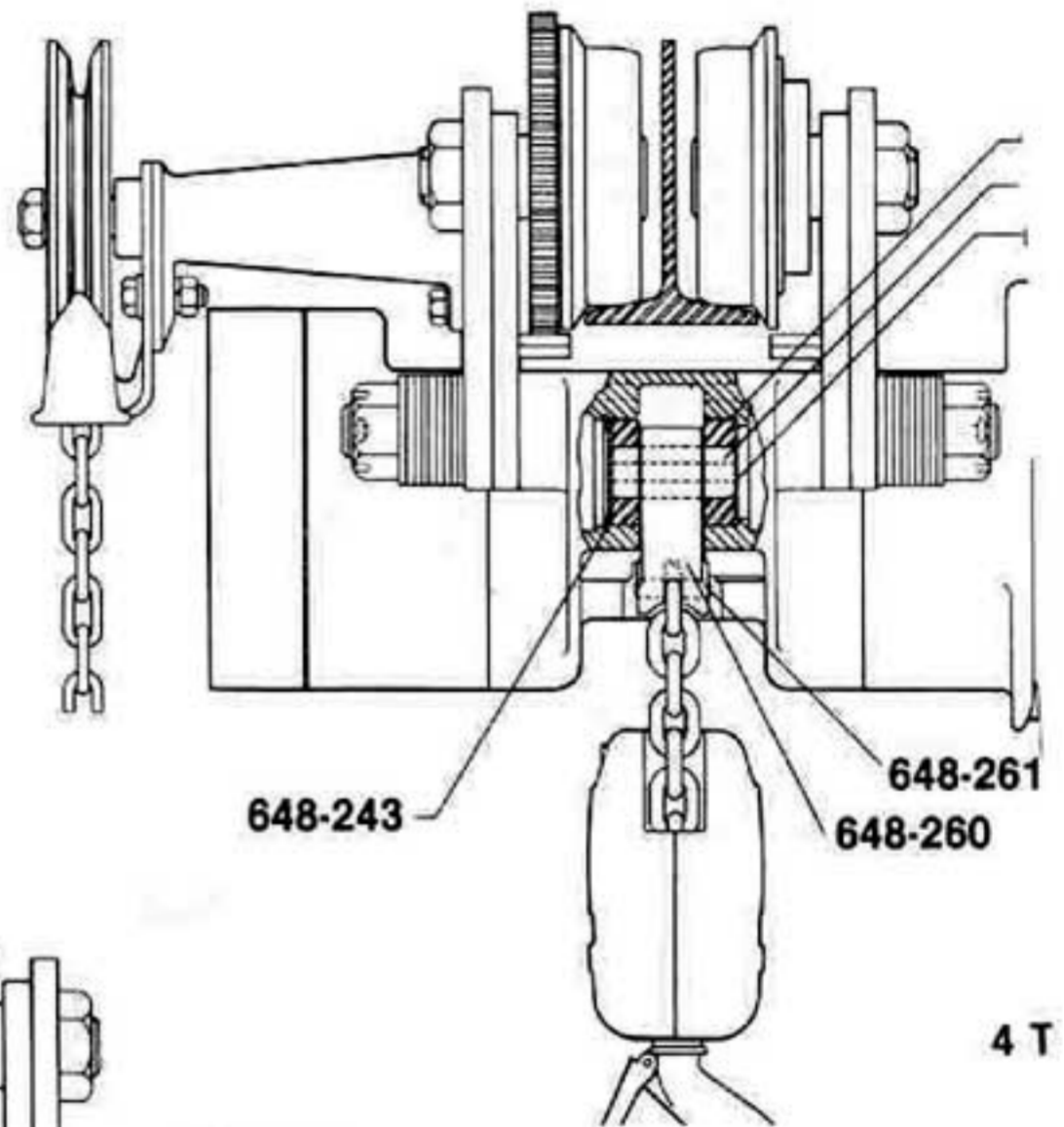

4 T

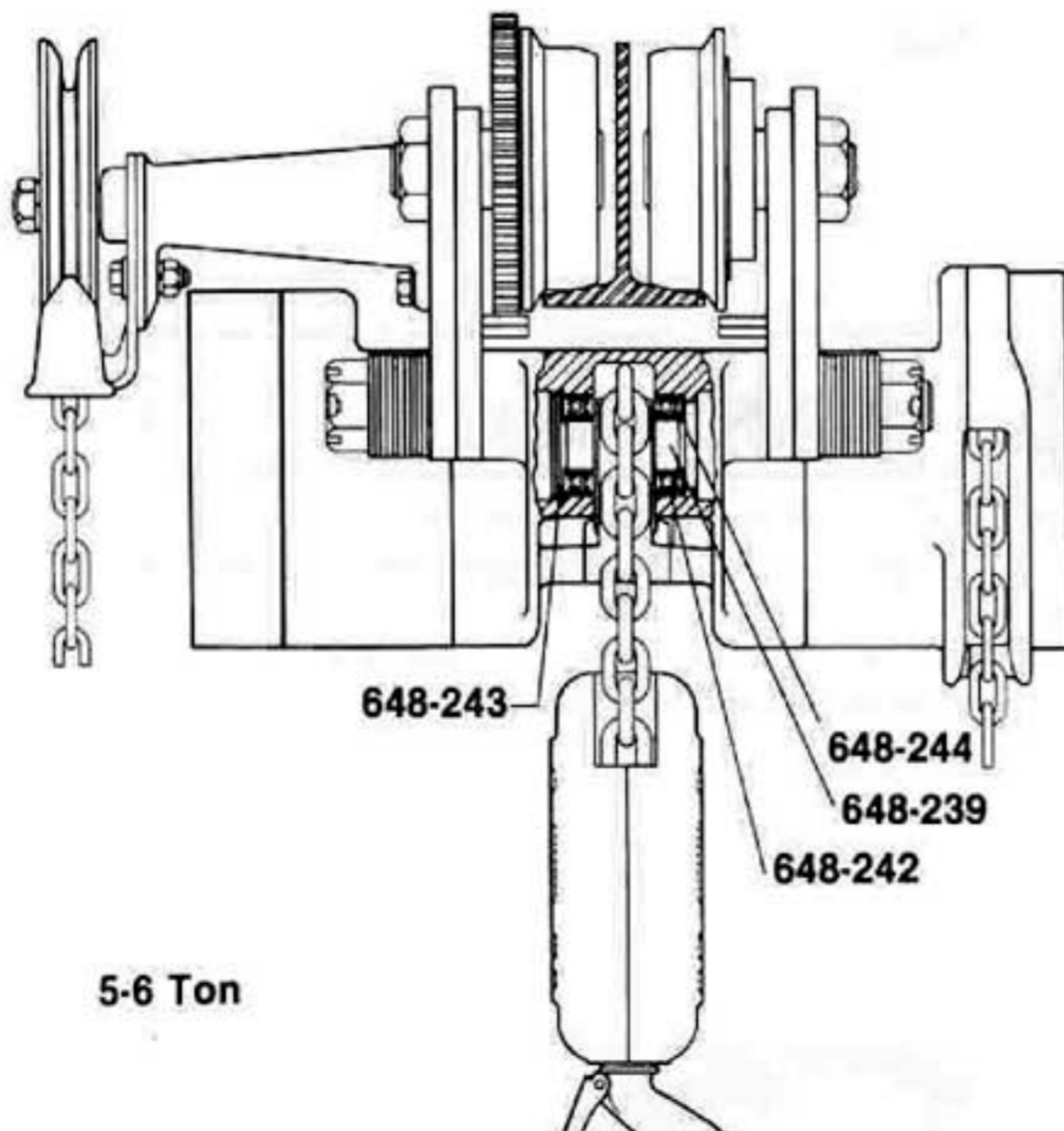

5-6 Ton

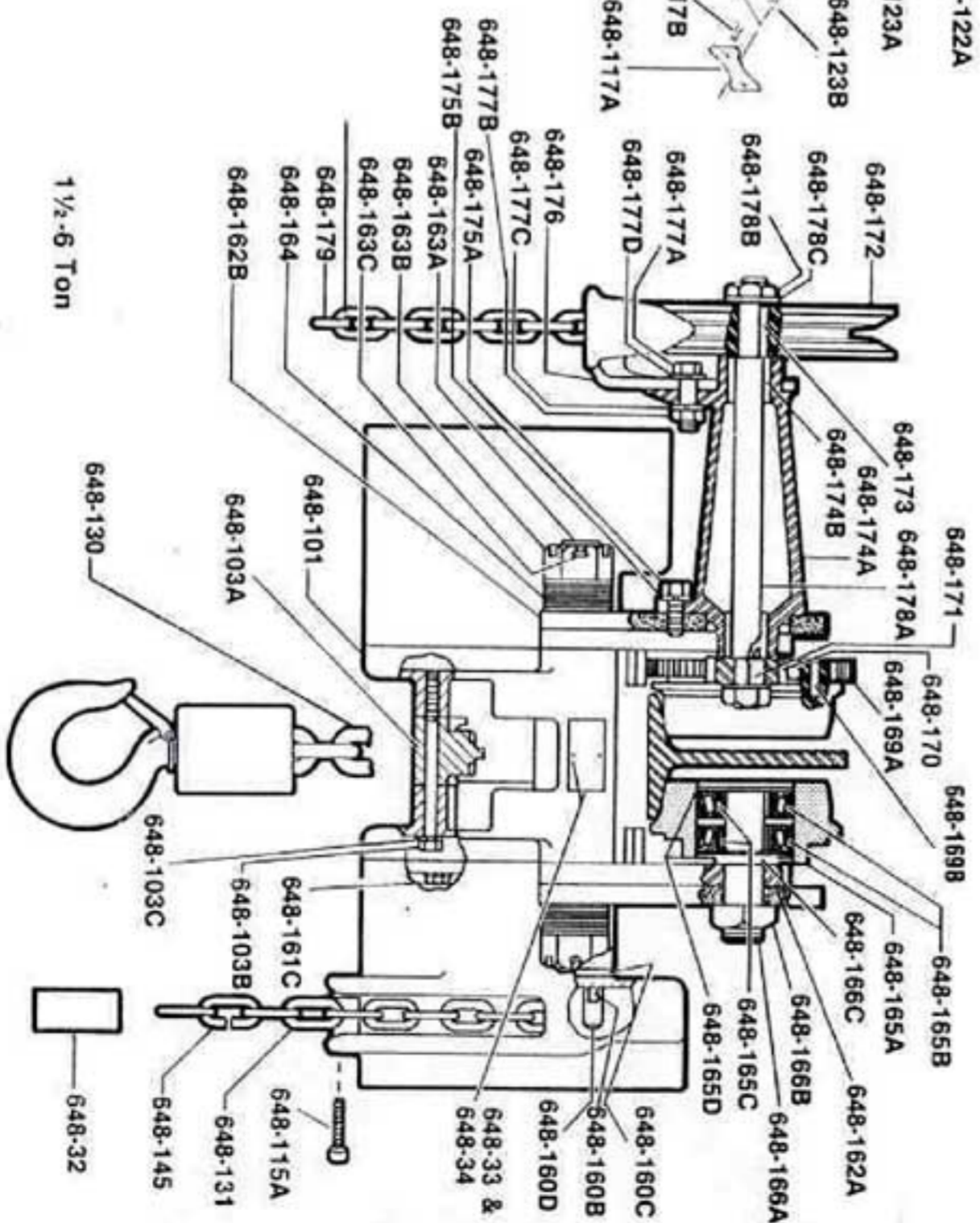
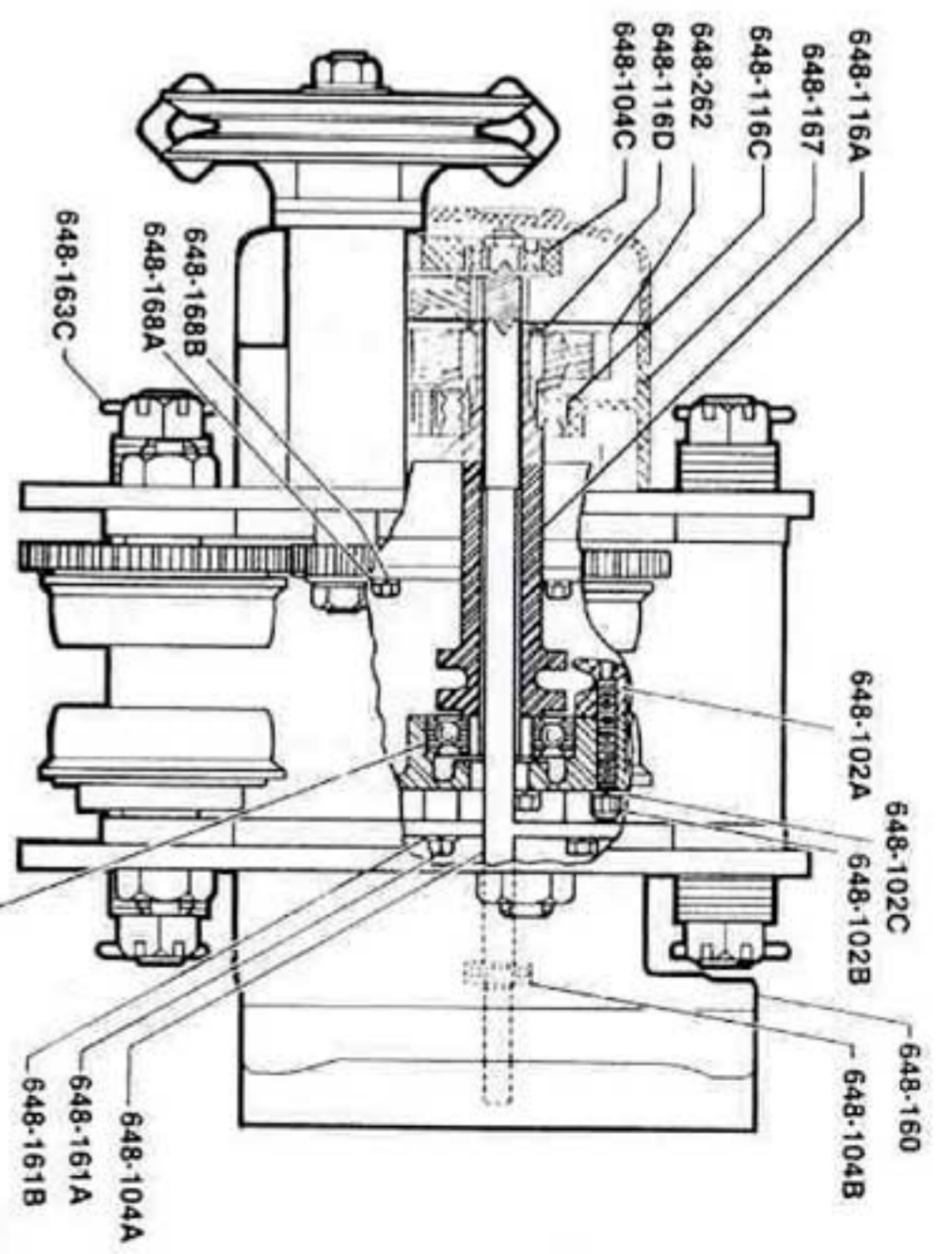
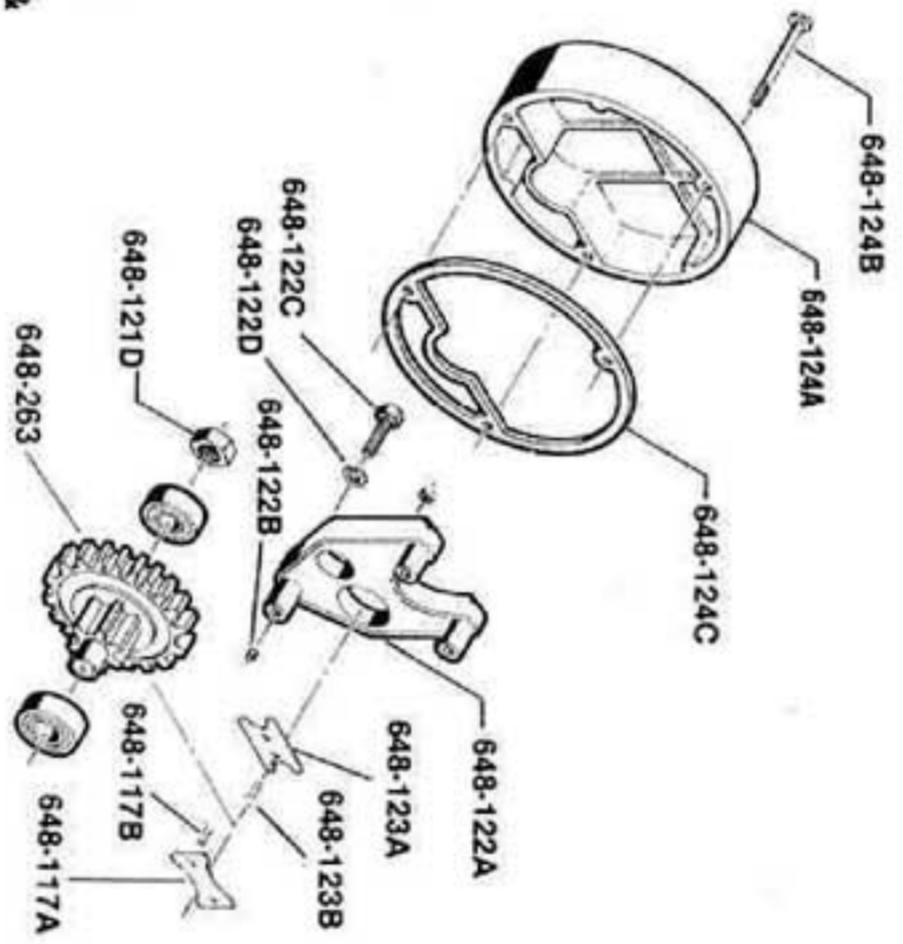
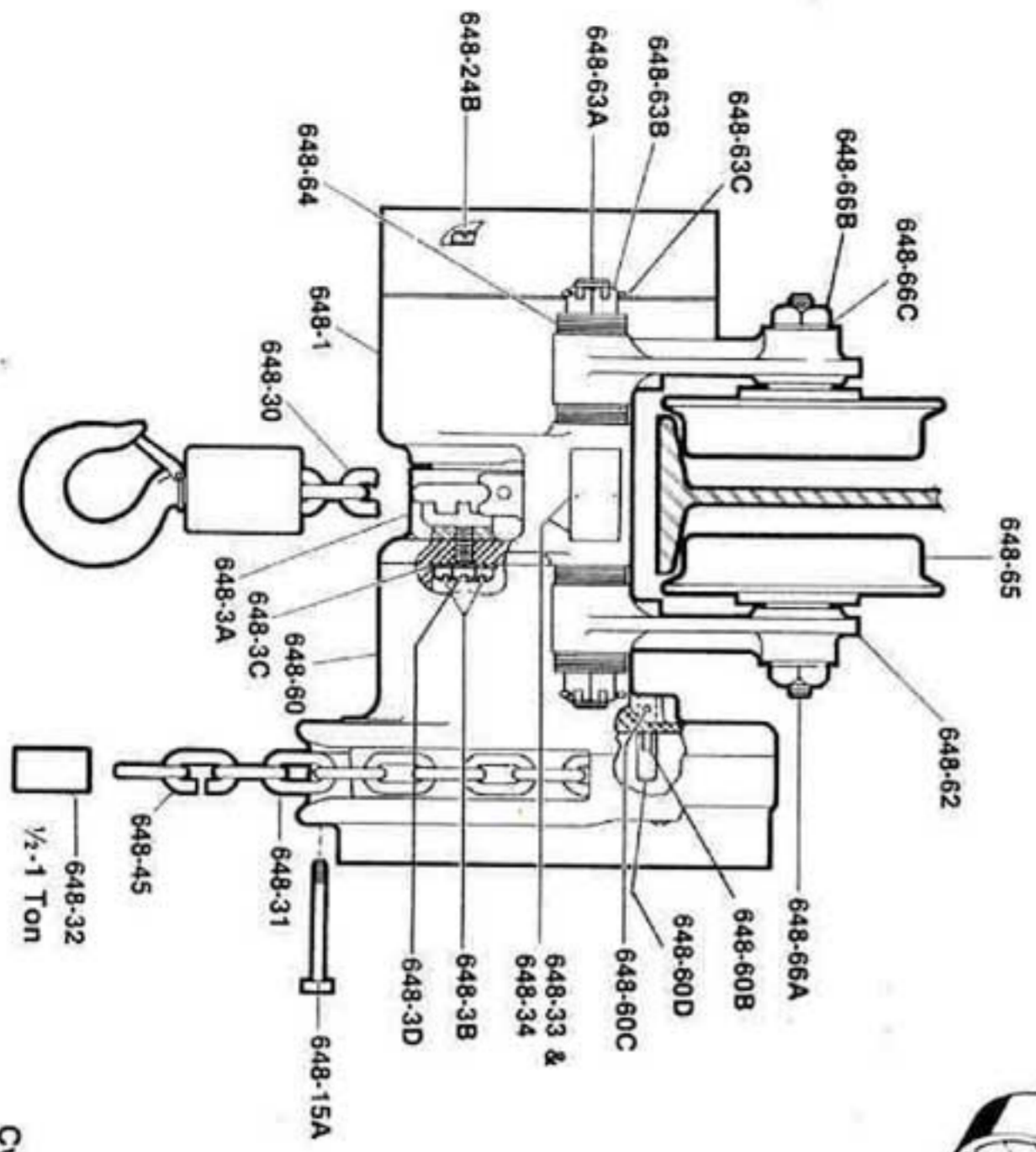
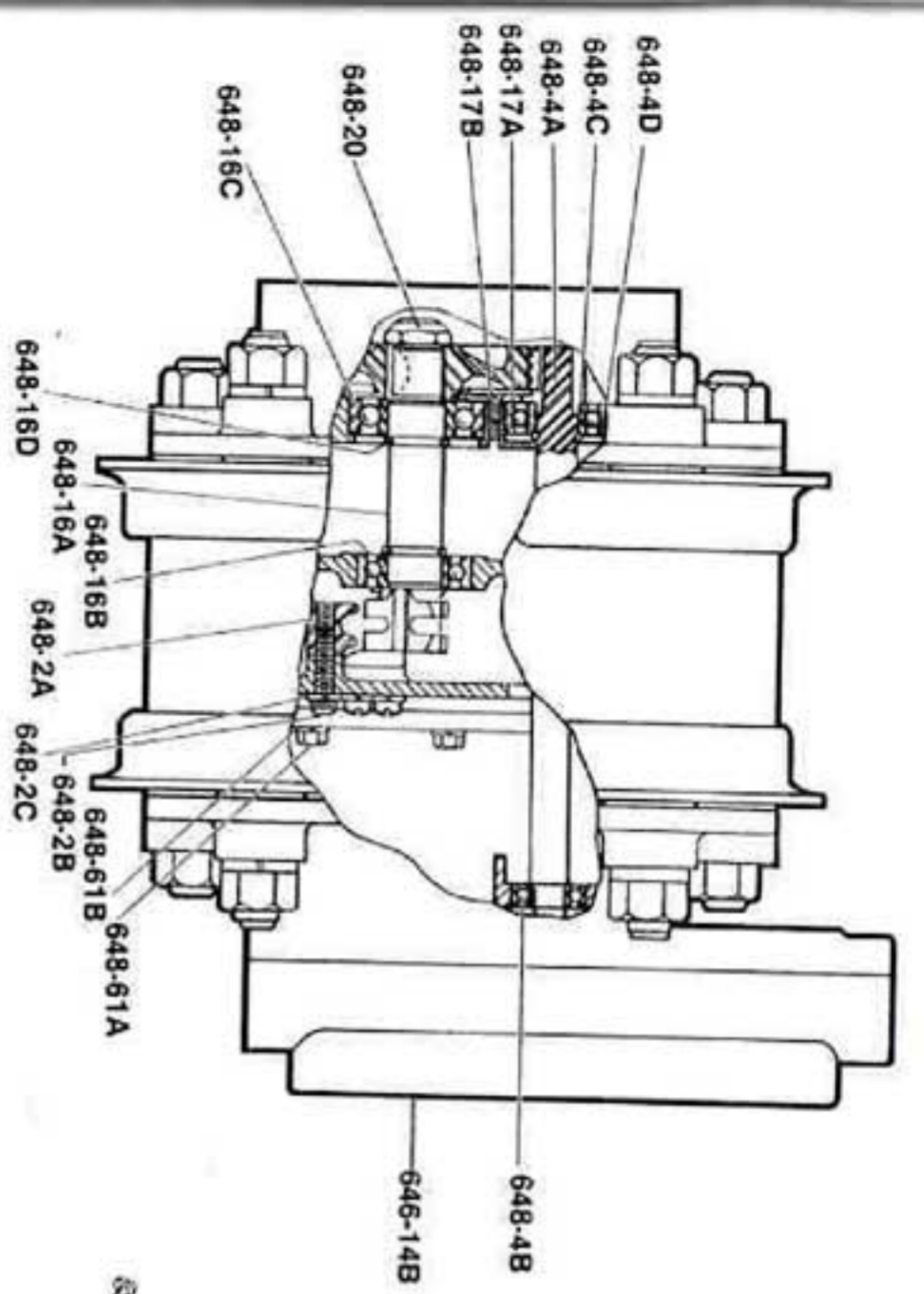

Figure 26.
Cyclone Low Headroom Trolley Hoist

CYCLONE HAND HOIST PARTS LIST

Key No.	No Req'd	Part Name	Capacity - Ton					
			1/4 & 1/2	1	1 1/2 & 2	3 & 4	5 & 6	8 & 10
			Part Number					
646-229B	1	Lower Hook Sleeve	-	-	-	45394	45393	45410
646-229G	1	Lower Hook Pin	-	-	-	983787	-	983788
646-229K	1	Lower Hook Nut	-	-	-	940834	-	945836
646-229L	1	Lower Hook Thrust Bearing	-	-	-	88507	-	88511
646-233A	1	Hoist Hanger (Also order 646-234A and 646-234B OR 646-234D as applicable)	-	-	-	45090	45091	45094
646-233B	1	Hoist Hanger Set Screw	-	-	-	986304	-	-
646-234A	1	Hoist Hanger Screw (Also order 646-234B or 646-234D as applicable)	-	-	-	987223	987179	-
646-234C	1	Hoist Hanger Screw Washer	-	-	-	945916	-	-
646-234D	1	Hoist Hanger Screw Pin	-	-	-	-	983789	-
646-235	1	Hoist Hanger Screw Sleeve	-	-	-	45391	-	-
646-236	1	Hoist Hanger Sheave Cap (Tapped)	-	-	-	-	-	45123
646-237	1	Hoist Hanger Sheave Cap (Drilled)	-	-	-	-	-	45124
646-238	1	Hoist Hanger Chain Anchor	-	-	-	-	-	45134 (8T.)
646-239	1 or 2	Hoist Hanger Sheave	-	-	-	-	45085	45106
646-241	1 or 2	Hoist Hanger Bearing	-	-	-	-	-	88542
646-242	2	Hoist Hanger Sheave Bearing	-	-	-	-	83670	-
646-243	1	Hoist Hanger Snap Ring	-	-	-	-	45765	-
646-244	2	Hoist Hanger Bearing Retainer	-	-	-	-	45151	-
646-245	2	Hoist Hanger Sheave Shaft	-	-	-	-	-	45425
646-246A	1	Hoist Hanger Sheave Shaft Bolt	-	-	-	-	-	89411
646-246B	1	Hoist Hanger Sheave Shaft Bolt L.W.	-	-	-	-	-	987919
646-247	2	Lower Hook Block (Also order capacity insert 646-275)	-	-	-	45107 (3T.) 45096 (4T.)	45101	-
646-248	1	Lower Hook Block Body (Also order Capacity insert 646-275)	-	-	-	-	-	45104 (8T.) 45104 (10T.)
646-249A	3	Lower Hook Block Screw	-	-	-	945796	45812	-
646-249B	3	Hook Block Screw Nut	-	-	-	945820	945822	-
646-249C	3	Hook Block Screw L.W.	-	-	-	945851	945853	-
646-250	1 or 2	Hook Block Sheave	-	-	-	45086	45106	-
646-252	1 or 2	Hook Block Sheave Bearing	-	-	-	-	88542	-
646-253	2	Hook Block Sheave Bearing	-	-	-	86370	-	-
646-254	1 or 2	Hook Block Sheave Shaft	-	-	-	-	45425	-
646-256A	1	Hook Block Sheave Shaft Bolt	-	-	-	-	-	89411
646-256B	1	Hook Block Sheave Shaft Bolt L.W.	-	-	-	-	-	987919
646-257	1	Hook Block Sheave Cap (Tapped)	-	-	-	-	-	45123
646-258	1	Hook Block Sheave Cap (Drilled)	-	-	-	-	-	45124
646-259	1	Dead End Pin	-	-	-	45945	-	45944
646-260	2	Reeving Caution Plate	-	-	-	45757	-	-
646-275	1	Capacity Insert	-	-	-	-	46712 (5 Ton) 46713 (6 Ton)	45837 (8 Ton) 45838 (10 ton)

Part Numbers for packaged lubricants used in Cyclone Hand and Low Headroom Trolley Hoists

Lubricant Usage	Type of Lubricant	Part Numbers and packaged Quantities of Lubricants
Gears	Grease	28610 (1#can) 28632 (4#can)
Handwheel Threads	Spray	46698 (16 oz.)
Chain	Oil	28608 (1 pt. can) 28619 (1 gal. can)
Trackwheel Bearings	Grease	28610 (1#can) 28632 (4#can)
Trackwheel Gears	*Heavy Cup Grease	-
Handwheel Shaft	*Light Machine Oil	-

*These are not furnished by CM in Packaged Quantities.
When ordering lubricants, specify the type of lubricant, part number and packaged quantity required.

Touch-up Paints for Cyclone Hand and Low Headroom Trolley Hoists:
1. Hoist. Order *(1) case (12-12 oz. Aerosol Cans) of Orange Touch-up paint Part Number 84190
2. Trolley. Order *(1) case (12-12 oz. Aerosol Cans) of Black Touch-up paint Part Number 84189.
*Touch-up paints are only available in case quantities.

NOTE: When painting Hoists or Trolleys, also order warning labels, identification labels, etc. that may be coated during painting.

CYCLONE HAND HOIST PARTS LIST

Key No.	No. Req'd.	Part Name	Capacity - Ton					
			1/4 & 1/2	1	1 1/2 & 2	3 & 4	5 & 6	8 & 10
			Part Number					
646-101B	1	Upper Hook (Includes Latch) Latch Type	—	—	45604	—	—	—
646-101B	1	Upper Hook—Latchlok Type	—	—	1023	—	—	—
646-101C	2	Upper Hook Washer	—	—	45918	—	—	—
646-101D	1	Upper Hook Collar	—	—	35478	—	—	—
646-101E	1	Upper Hook Collar Pin	—	—	45946	—	—	—
646-102A	1	Load Chain Guide	—	—	—	45049	—	—
646-102B	3	Load Chain Guide Screw	—	—	—	945815	—	—
646-102C	3	Load Chain Guide Screw L.W.	—	—	—	45852	—	—
646-103A	1	Stripper	—	—	—	45420	—	—
646-103B	2	Stripper Screw	—	—	—	982709	—	—
646-104	1	Handwheel Shaft and Pinion with Bearings (Items 646-104A, 646-104B and 646-104C)—Not Shown	—	—	—	C710 For 1 1/2 & 3 Ton, C711 2, 4, 5, 6, 8 & 10 Ton		
646-104A	1	Handwheel Shaft and Pinion	—	—	45355 for 1 1/2 & 3 Ton, 45356 for 2, 4, 5, 6, 8 & 10 Ton	—	—	—
646-104B	1	Handwheel Shaft Bearing (Handwheel End)	—	—	—	88437	—	—
646-104C	1	Handwheel Shaft Bearing (Pinion End)	—	—	—	83671	—	—
646-116	1	Liftwheel with Bearings (Items 646-116A thru 646-116E)—Not Shown	—	—	—	C712	—	—
646-116A	1	Liftwheel	—	—	—	45057	—	—
646-116B	1	Liftwheel Bearing (Handwheel End)	—	—	—	88445	—	—
646-116C	1	Liftwheel Bearing (Gear End)	—	—	—	83669	—	—
646-116D	1	Liftwheel Snap Ring	—	—	—	45766	—	—
646-116E	1	Liftwheel Bearing Retaining Ring (Gear End)	—	—	—	46800	—	—
646-118	1	Liftwheel Gear	—	—	—	45008	—	—
646-119	2	Liftwheel Dowell Pin	—	—	—	45771	—	—
646-121	1	Intermediate Gear and Pinion with Bearings (Items 646-121A, 646-121B and 646-121C)—Not Shown	—	—	—	C713 For 1 1/2 & 3 Ton, C714 for 2, 4, 5, 6, 8 & 10 Ton		
646-121A	1	Intermediate Gear & Pinion	—	—	—	45014 for 1 1/2 & 3 Ton (7 & 45 Teeth) 45015 for 2, 4, 5, 6, 8 & 10 Ton (7 & 47 Teeth)		
646-121B	1	Intermediate Gear Bearing (Pinion End)	—	—	—	83682	—	—
646-121C	1	Intermediate Gear Bearing (Cover End)	—	—	—	88437	—	—
646-122	2	Gear Cover Dowel	—	—	—	46730	—	—
646-124	1	Gear Cover with Capacity Insert	—	—	—	C715 for 1 1/2 ton, C723 for 2 ton, C724 for 3 ton, C725 for 4 ton, C726 for 5 ton, C727 for 6 ton, C728 for 8 ton and C729 for 10 ton		
646-124A	1	Capacity Insert	—	—	—	46708 (1 1/2 ton), 46709 (2 ton), 46710 (3 ton) 46711 (4 ton), 46712 (5 ton), 46713 (6 ton), 46714 (8 ton), 46715 (10 ton)		
646-124B	2	Capacity Insert Pin	—	—	—	988271	—	—
646-124C	3	Gear Cover Screw	—	—	—	983732	—	—
646-124D	1	Gear Cover Gasket	—	—	—	46704	—	—
646-125A	1	Loose End Screw	—	—	—	945815	—	—
646-125B	1	Loose End Screw L.W.	—	—	—	945852	—	—
646-125C	1	Loose End Screw Washer	—	—	—	954806	—	—
646-129	1	Lower Hook and Block Assembly—Latch Type Hook	—	—	45669	—	—	—
646-129A	1	Lower Hook with Latch—Latch Type Hook	—	—	45603	—	—	—
646-129A	1	Lower Hook—Latchlok Type Hook	—	—	1024	—	—	—
646-129B	1	Hook Block Body	—	—	45399	—	—	—
646-129E	1	Lower Hook Thrust Bearing	—	—	88505	—	—	—
646-129F	1	Lower Hook Nut	—	—	45382	—	—	—
646-129G	1	Lower Hook Nut Pin	—	—	983779	—	—	—
646-129H	1	Lower Hook Chain Block	—	—	45017	—	—	—
646-129J	1	Hook Block Pin	—	—	45948	—	—	—
646-130	1	Load Chain (Specify Lift or Length Req'd.)	—	—	—	85864	—	—
646-131	1	Hand Chain (Specify Lift or Length Req'd.)	—	—	—	85808	—	—
646-132	1	Load Limiter Complete	—	—	44602 for 1/4 Ton, 44601 for 1/2 Ton, 44600 for 1 thru 10 Ton	—	—	—
646-133	1	Handwheel Sub-Assembly	—	—	—	45675	—	—
646-134	1	Load Limiter Hub	—	—	—	45012	—	—
646-135	2	Friction Washer	—	—	—	45886	—	—
646-136	1	Steel Washer	—	—	—	45032	—	—
646-137	1	Spring Washer	—	—	—	45888	—	—
646-138	1	Lockwasher	—	—	—	45033	—	—
646-139	1	Nut	—	—	—	45737	—	—
646-144	2	Latch Kit	—	—	45663	—	—	—
646-201B	1	Upper Hook (includes Latch)—Latch Type	—	—	—	45607	45606 (5T.) 40607 (6T.)	45609
646-201B	1	Upper Hook—Latchlok Type	—	—	—	1025	1027	1028
646-201C	2	Upper Hook Washer	—	—	—	40736	—	988005
646-201E	1	Upper Hook Nut Pin	—	—	—	983787	—	983788
646-201F	1	Upper Hook Nut	—	—	—	940834	—	945836
646-206	2	Latch Kit	—	—	—	45664	45664 (5T.) 45665 (6T.)	*45697
646-229	1	Lower Hook Block Assembly—Not Shown	—	—	—	45670 for 3 Ton, 45615 for 4 Ton, 45616 for 5 Ton, 45617 for 6 Ton 45618 for 8 Ton, 45619 for 10 Ton		
646-229A	1	Lower Hook (Includes Latch)—Latch Type	—	—	—	45605	45606 (5T.) 40607 (6T.)	45609
646-229A	1	Lower Hook—Latchlok Type	—	—	—	1026	1027	1028

18 *NOTE: 8 ton units before serial no. S-A006GT used latch kit part number 45696.

CYCLONE HAND HOIST PARTS LIST

Key No.	No. Req'd.	Part Name	Capacity - Ton					
			1/4 & 1/2	1	1-1/2 & 2	3 & 4	5 & 6	8 & 10
			Part Number					
646-1	1	Frame with Upper Hook (Includes Items 646-1A thru 646-1F and 646-15) - Not Shown	C701	C702				
646-1A	1	Frame	45612					
646-1B	1	Upper Hook (Includes Latch)-Latch Type	45601	45602				
646-1B	1	Upper Hook-Latchlok Type	1020	1022				
646-1C	2	Upper Hook Washer	45930					
646-1D	1	Upper Hook Collar	41350	27359				
646-1E	1	Upper Hook Collar Pin	45940	45941				
646-1F	1	Upper Hook Sleeve	45390					
646-2A	1	Load Chain Guide	45047	45048				
646-2B	2	Load Chain Guide Screw	945807					
646-2C	2	Load Chain Guide Screw L.W.	945851					
646-3A	1	Stripper	45043					
646-3B	3	Stripper Screw	983745					
646-3C	1	Stripper Screw L.W.	940830					
646-4	1	Handwheel Shaft and Pinion with Bearings (Items 646-4A thru 646-4D)-Not Shown	C703	C704				
646-4A	1	Handwheel Shaft and Pinion	45353	45354				
646-4B	1	Pinion Shaft Bearing (Handwheel End)	88437					
646-4C	1	Pinion Shaft Bearing (Gear End)	88444					
646-4D	1	Handwheel Shaft Snap Ring	45873					
646-5	1	Pawl			45038			
646-5A	1	Pawl Bushing			45735			
646-6	1	Pawl Retaining Washer			45910			
646-7	1	Pawl Stud Snap Ring			45767			
646-8	1	Pawl Spring			45730			
646-9	1	Brake Assembly (Items 646-9A, 646-9B and 646-9CD)-Not Shown			C705			
646-9A	1	Friction Hub			45007			
646-9B	2	Friction Washer	45741 FOR UNITS WITH LOAD LIMITER, 45831 FOR UNITS WITHOUT LOAD LIMITER					
646-9CD	1	Ratchet with Bushing			45614			
646-9D	1	Ratchet Bushing			45718			
646-10	1	Non-Load Limiter Handwheel			46699			
646-11	1	Handwheel Shaft Nut Washer			45915			
646-12	1	Handwheel Shaft Nut			931717			
646-13	1	Friction Hub Key			45770			
646-14	1	Handwheel Cover			46005			
646-14A	1	Cover Label	946753					
646-15	1	Operating Instruction Label (See Page 16)-Not Shown			946900			
646-15A	3	Handwheel Cover Screw			982698			
646-16	1	Liftwheel with Bearings (Items 646-16A thru 646-16D)-Not Shown	C706	C707				
646-16A	1	Liftwheel	45364	45365				
646-16B	1	Liftwheel Bearing (Handwheel End)	88489					
646-16C	1	Liftwheel Bearing (Gear End)	88429					
646-16D	1	Liftwheel Snap Ring	45871					
646-17A	1	Frame Bearing Retainer	45750					
646-17B	2	Frame Bearing Retainer Screw	987718					
646-18	1	Liftwheel Gear	45061	45060				
646-19	1	Liftwheel Gear Key	989101					
646-20	1	Liftwheel Gear Snap Ring	68703					
646-24	1	Gear Cover with Capacity Insert	C708 for 1/4 ton, C721 for 1/2 ton and C722 for 1 ton					
646-24A	1	Capacity Insert	48705 (1/4 ton) 45706 (1/2 ton) 46707 (1 ton)					
646-24B	2	Capacity Insert Pin			988271			
646-24C	3	Gear Cover Screw	987322					
646-24D	1	Gear Cover Gasket	45747					
646-25A	1	Loose End Screw	946801					
646-25B	1	Loose End Screw Washer	954807					
646-29	1	Lower Hook and Block Assembly-Latch Type Hook	28681	45668				
646-29A	1	Lower Hook with Latch-Latch Type Hook	28886	35611				
646-29A	1	Lower Hook-Latchlok Type Hook	1051					
646-29B	1	Hook Block Body	45401					
646-29D	1	Lower Hook Washer	945921					
646-29E	1	Lower Hook Thrust Bearing	88485					
646-29F	1	Lower Hook Nut	982526					
646-29G	1	Lower Hook Nut Pin	983772					
646-29H	1	Lower Hook Chain Block	28007	45016				
646-29J	1	Hook Block Pin	45943					
646-30	1	Load Chain (Specify Lift or Length Req'd.)	85839	85841				
646-31	1	Hand Chain (Specify Lift or Length Req'd.)	85808					
646-32	1	Warning Tube			946735			
646-38	2	Latch Kit	45661	45662				
646-45	1	Hand Chain Connecting Link			945490			
646-101	1	Frame with Upper Hook (Includes Items 646-101A thru 646-101E AND 646-15)-Not Shown			C730			
646-101A	1	Frame					45613	