

# SHOPAIR™



## Capacities

**250 lbs (113 kg)    300 lbs (136 kg)**  
**500 lbs (226 kg)    600 lbs (272 kg)**

**Follow all instructions and warnings for inspecting, maintaining and operating this hoist.**

The use of any hoist presents some risk of personal injury or property damage. That risk is greatly increased if proper instructions and warnings are not followed. Before using this hoist, each operator should become thoroughly familiar with all warnings, instructions, and recommendations in this manual. **Retain this manual for future reference and use.**

Forward this manual to the hoist operator.

Failure to operate the equipment as directed in the manual may cause injury.

Should you have any questions or have problems with this product, please call Product Standards and Service at 1-800-634-4647.

Before using the hoist, fill in the information below. Model and serial numbers are stamped into the aluminum hoist housing.

Model Number \_\_\_\_\_

Serial Number \_\_\_\_\_

Purchase Date \_\_\_\_\_



Columbus McKinnon Corporation  
Industrial Products Division  
140 John James Audubon Parkway  
Amherst, New York 14228-1197

Note: When ordering parts, always furnish Rated Load and Serial Number of hoist on which the parts are to be used.

For the location of the nearest Repair Station, see the list located on the inside front cover.

## LIMITATION OF WARRANTIES, REMEDIES AND DAMAGES

THE WARRANTY STATED BELOW IS GIVEN IN PLACE OF ALL OTHER WARRANTIES, EXPRESS OR IMPLIED, OF MERCHANTABILITY, FITNESS FOR A PARTICULAR PURPOSE, OR OTHERWISE, NO PROMISE OR AFFIRMATION OF FACT MADE BY ANY AGENT OR REPRESENTATIVE OF SELLER SHALL CONSTITUTE A WARRANTY BY SELLER OR GIVE RISE TO ANY LIABILITY OR OBLIGATION.

Seller warrants that on the date of delivery to carrier the goods are free from defects in workmanship and materials.

SELLER'S SOLE OBLIGATION IN THE EVENT OF BREACH OF WARRANTY OR CONTRACT OR FOR NEGLIGENCE OR OTHERWISE WITH RESPECT TO GOODS SOLD SHALL BE EXCLUSIVELY LIMITED TO REPAIR OR REPLACEMENT, F.O.B. SELLER'S POINT OF SHIPMENT, OF ANY PARTS WHICH SELLER DETERMINES TO HAVE BEEN DEFECTIVE or if Seller determines that such repair or replacement is not feasible, to a refund of the purchase price upon return of the goods to Seller.

Any action against Seller for breach of warranty, negligence or otherwise, must be commenced within one year after such cause of action occurs.

NO CLAIM AGAINST SELLER FOR ANY DEFECT IN THE GOODS SHALL BE VALID OR ENFORCEABLE UNLESS BUYER'S WRITTEN NOTICE THEREOF IS RECEIVED BY SELLER WITHIN ONE YEAR FROM THE DATE OF SHIPMENT. Seller shall not be liable for any damage, injury or loss arising out of the use of the goods if, prior to such damage, injury or loss, such goods are (1) damaged or misused following Seller's delivery to carrier; (2) not maintained, inspected, or used in compliance with applicable law and Seller's written instructions and recommendations; or (3) installed, repaired, altered or modified without compliance with such law, instructions or recommendations.

UNDER NO CIRCUMSTANCES SHALL SELLER BE LIABLE FOR INCIDENTAL OR CONSEQUENTIAL DAMAGES AS THOSE TERMS ARE DEFINED IN SECTION 2-715 OF THE UNIFORM COMMERCIAL CODE.

### INDEMNIFICATION AND SAFE OPERATION

Buyer shall comply with and require its employees to comply with directions set forth in instructions and manuals furnished by Seller and shall use and require its employees to follow such instructions and manuals and to use reasonable care in the use and maintenance of the goods. Buyer shall not remove or permit anyone to remove any warning or instruction signs on the goods. In the event of personal injury or damage to property or business arising from the use of the goods, Buyer shall within 48 hours thereafter give Seller written notice of such injury or damage. Buyer shall cooperate with Seller in investigating any such injury or damage and in the defense of any claims arising therefrom.

If Buyer fails to comply with this section or if any injury or damage is caused, in whole or in part, by Buyer's failure to comply with applicable federal or state safety requirements, Buyer shall indemnify and hold Seller harmless against any claims, loss or expense for injury or damage arising from the use of the goods.

## WARNING

Alterations or modifications of equipment and use of non-factory repair parts can lead to dangerous operation and injury.

### TO AVOID INJURY:

- Do not alter or modify equipment.
- Do use only factory replacement parts.



Columbus McKinnon Corporation • Industrial Products Division • 140 John James Audubon Parkway  
Amherst, New York 14228-1197 • 1-800-888-0985 • Fax 716-689-5644



## SHOPAIR PARTS LIST

Key No.	Description	Qty.	Part No.
620-107	Main Frame	1	20300
620-108	Liftwheel Seal	1	20705
620-109	Protector Bearing, Main Frame Side	1	88636
620-111	Protector Assembly	1	20645
620-112	Thrust Washer, Second Pinion	2	88640
620-113	Gear Housing	1	20301
620-114	Protector Bearing, Gear Housing Side	1	88636
620-115	First Pinion Bearing	1	88635
620-116	Brake Base Plate	1	20724
620-117	Brake Disc	1	20722
620-119	Brake Driver	1	20776
620-120	Brake Driver Pin`	1	983976
620-121	Leaf Spring	1	20775
620-125	Pin Plate	1	20700
620-126	Pin Plate Screw	2	20743
620-127	Liftwheel and Gear Assembly	1	20664
620-128	Liftwheel Bearing	2	88637
620-129	Thrust Washer, Liftwheel	2	88638
620-130	Liftwheel Shaft Seal	1	20704
620-131	First Pinion and Shaft	1	20306
620-134	Gear Housing Screw	4	920718
620-136	Dowel Pin	4	920720
620-137	Upper Hook	1	20650
620-138	Hook Latch Kit	2	595522
620-139	Hook Retainer	1	20712
620-140	Hook Retainer Screw	1	920722
620-141	Chain Guide	1	20304
620-142	Chain Guide Pin	4	20729
620-143	Chain Stripper	1	20305
620-144	Load Chain (Specify Length Req'd.)	--	85988
620-145	Loose End Ring	1	20744
620-146	Chain Stop	1	20319
620-147	Chain Stop Screw	1	25858
620-148	Liftwheel Shaft	1	20313
620-149	Thrust Washer, First Pinion	2	88639
620-155	Caution Label	1	20758
620-156	Hook Block 250# and 300#	2	20742
	500# and 600#	2	20739
620-157	Hook Block Screw 250# and 300#	2	920723
	500# and 600#	2	920724
620-158	Chain Pin 250# and 300#	1	920720
620-159	Hook (includes 620-138)	1	23030

Key No.	Description	Qty.	Part No.
620-160	Dead End Plate 500# and 600#	1	20714
620-161	Dead End Pin 500# and 600#	1	920720
620-162	Sheave Wheel (includes 620-164) 500# and 600#	1	20652
620-163	Sheave Wheel Shaft 500# and 600#	1	20318
620-164	Sheave Wheel Bearing 500# and 600#	1	88641
620-165	Sheave Wheel Thrust Washer 500# and 600#	2	88639
620-168	Dead End Plate Screw 500# and 600#	2	986185
620-174	Gasket	1	20755

### Part Number for Packaged Lubricants Used in the ShopAir *(Refer to Page 6 for Lubrication Instructions)*

Lubricant Usage	Type Lubricant	Part Numbers and Packaged Quantity of Lubricants
Hoist Gears	Grease Century Lubricants HB-11,#3	28605 for 1/2 lb. Can 28616 for 1 lb. Can 28617 for 4 lb Can
Spline on end First Pinion and Shaft	Oil-Graphite Mixture Hercules Packing Co. Moly-Duolube	40628 for 1 Pint Can
Load Chain	Oil Friske Bros. Lubriplate® Bar and Chain Oil #10R	28608 for 1 Pint Can 28619 for 1 Gal. Can
Lower Hook Knob	Grease Dow Corning Molykote BR-2-S	28606 for 1/2 lb. Can 28618 for 1 lb. Can

When ordering lubricants, specify the type of lubricant, part number and packaged quantity required.

## SHOPAIR PARTS LIST

Key No.	Description	Qty.	Part No.
620-103	Rotor Bearing, Inboard	1	88486
620-116	Brake Base Plate	1	20724
620-118	Armature Plate	1	20888
620-123	Brake Spring	1	20887
620-124	Brake Screw	4	920740
620-193	Brake Spacer	1	20723
620-169	Capacity Plate 250#	1	20762
	300#	1	20737
	500#	1	20763
	600#	1	20738
620-501	ShopAir Label	1	20943
620-502	Motor Cover, Orange	1	20415C
620-503	Cylinder Cap	1	20389
620-504	Motor Cover Screw (1.75" Lg.)	1	20947
620-505	Motor Cover Screw (3.50" Lg.)	1	20957
620-506	Motor Cover Screw (5.75" Lg.)	1	20945
620-507	Brake Cover Screw	3	20946
620-508	Motor Coupling	1	20391
620-509	Air Tubing (Specify Length Req'd.)	1	20948
620-510	Air Motor Screw	2	20958
620-511	Valve Body	1	20392
620-512	Piston Return Spring	2	20949
620-513	Spring Seat	2	20393
620-514	Piston	2	20394
620-515	Valve Gasket	1	20951
620-516	Supply Block	1	20395
620-517	Valve Body Screw	6	20959
620-518	Valve Bolt	2	20396
620-519	Swivel Elbow	4	20952
620-520	Male Connector	6	20953
620-521	Brake Piston	1	20397
620-522	Piston Spring	1	20954
620-523	Brake Coupling	1	20399
620-524	Air Cylinder	1	20398
620-525	Brake Shuttle Valve	1	20955
620-526	Swivel Fitting	1	20956
620-527	Brake End Spacer, Orange	1	20413C
620-528	Motor End Spacer, Orange	1	20414C
620-529	Control Tube (Specify Length Req'd.)	1	83945
620-530	Set Screw	1	20960
620-531	Pendant Throttle Control	1	647521600
620-533	Brake Cover, Orange	1	20411C
620-534	Muffler	1	20963
620-535	Piston Seal	1	11388201
620-536	Piston Shaft Seal	1	11025019
620-537	Coupling Pin	2	982315
620-538	Air Motor	1	20950
620-539	Air Motor Screw Lockwasher	2	957844

Key No.	Description	Qty.	Part No.
620-540	O-Ring	4	20991
620-541	Warning Tube	1	687J6
620-542	Coupling	1	20990
620-543	Control Tube and Pendant Throttle Control for 10 ft. (3m) lift. For other Lifts, contact CM.	1	20680
620-550	Lever Pin	2	647521606S
620-551	Lever	2	648888613S
620-552	Throttle Valve	2	648885601S
620-553	Throttle Valve Seal	4	648885602S
620-554	Throttle Valve Spring	2	648885615S
620-555	Throttle Valve Cap	2	648885616S
620-556	Throttle Valve Cap Seal	2	648885617S
620-557	Housing	-	Order Complete Station
620-558	Valve Housing	-	Order Complete Station
620-559	Valve Housing Seal	2	648885611S
620-560	Valve O-Ring	1	648885603S
620-561	"S" Hook	1	10814701
620-562	Motor Gasket	1	20965
620-563	Ejector Ring	2	20966
620-564	Vane	4	20967
620-565	Rotor Assembly	1	20983
620-566	Front Cover	1	20982
620-567	Cover Screw	4	20984
620-568	Rotor Shaft Bearing	1	20985
620-569	Alignment Pin	4	20986
620-570	Oil Seal	1	20987
620-571	Snap Ring	1	20988
620-573	Strain Line Sleeve	1	989873

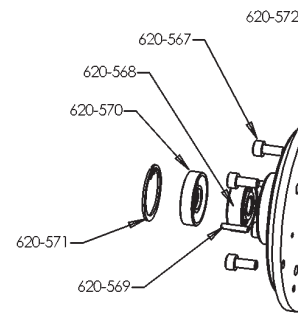

FOR GEARBOX ASSEMBLY AND LOWER HOOK PARTS SEE PAGES 12

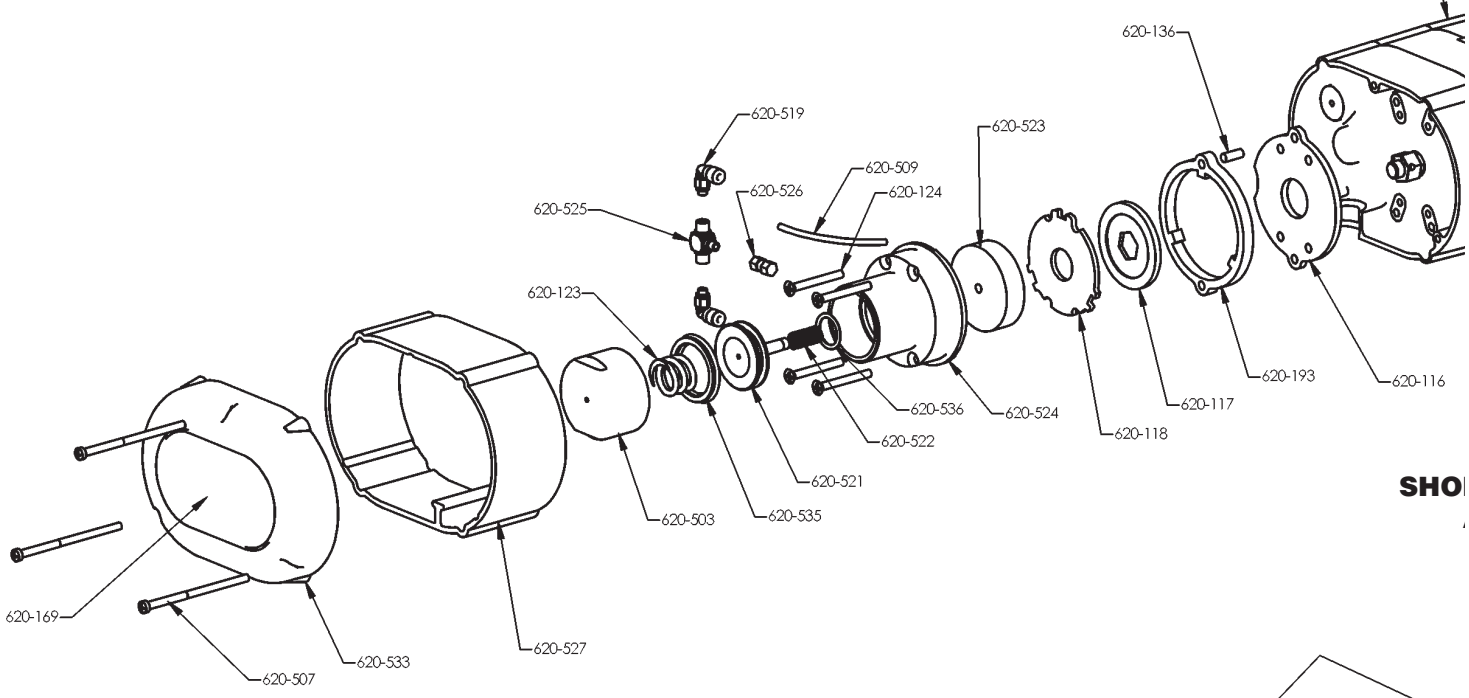

SHO

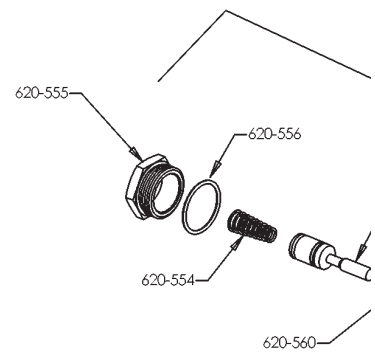

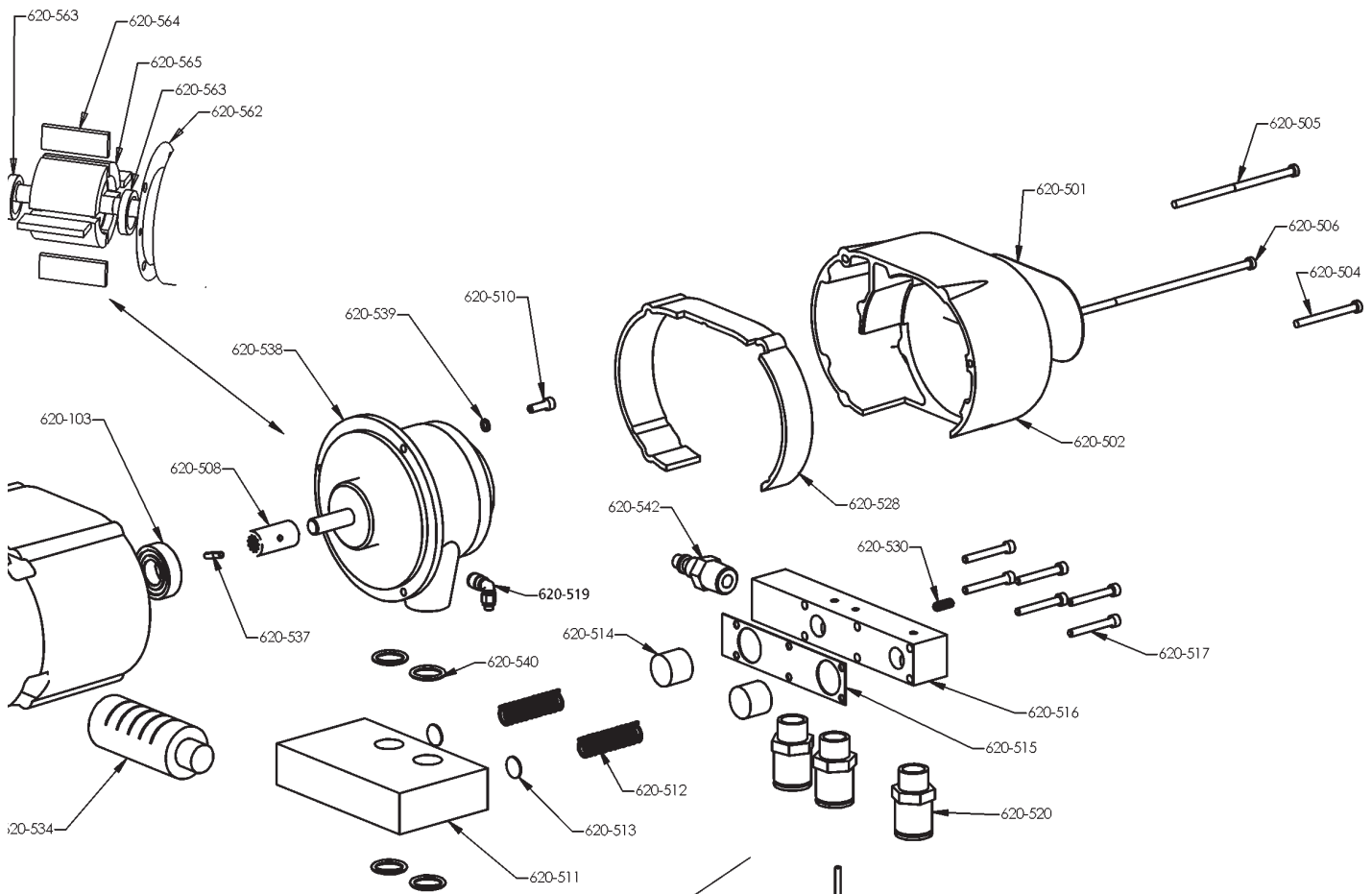

**EXPLODED VIEW  
HOIST PARTS**

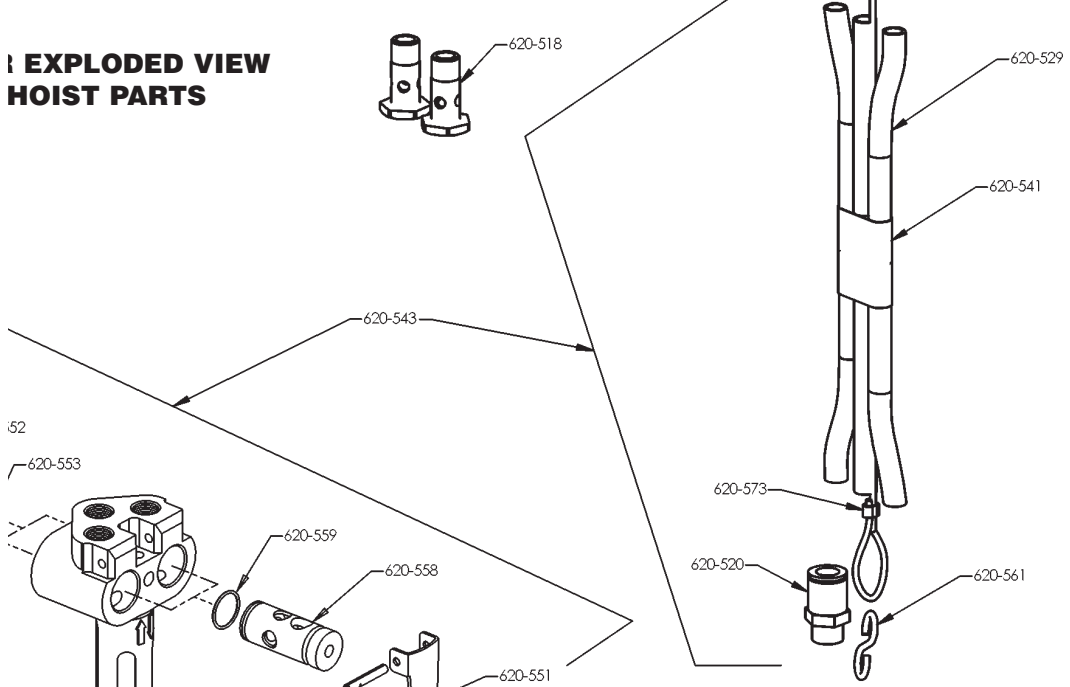

**PENDANT THROTTLE  
CONTROL COMPLETE  
620-531**

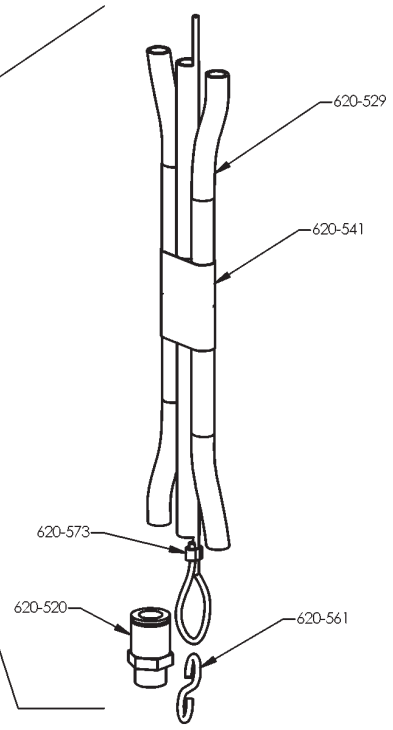

**SHOPAIR  
AIR CHAIN HOIST  
EXPLODED VIEW**