

**Push type bridges with
angle end trucks**
Catalog 905360, 905361 and
905362

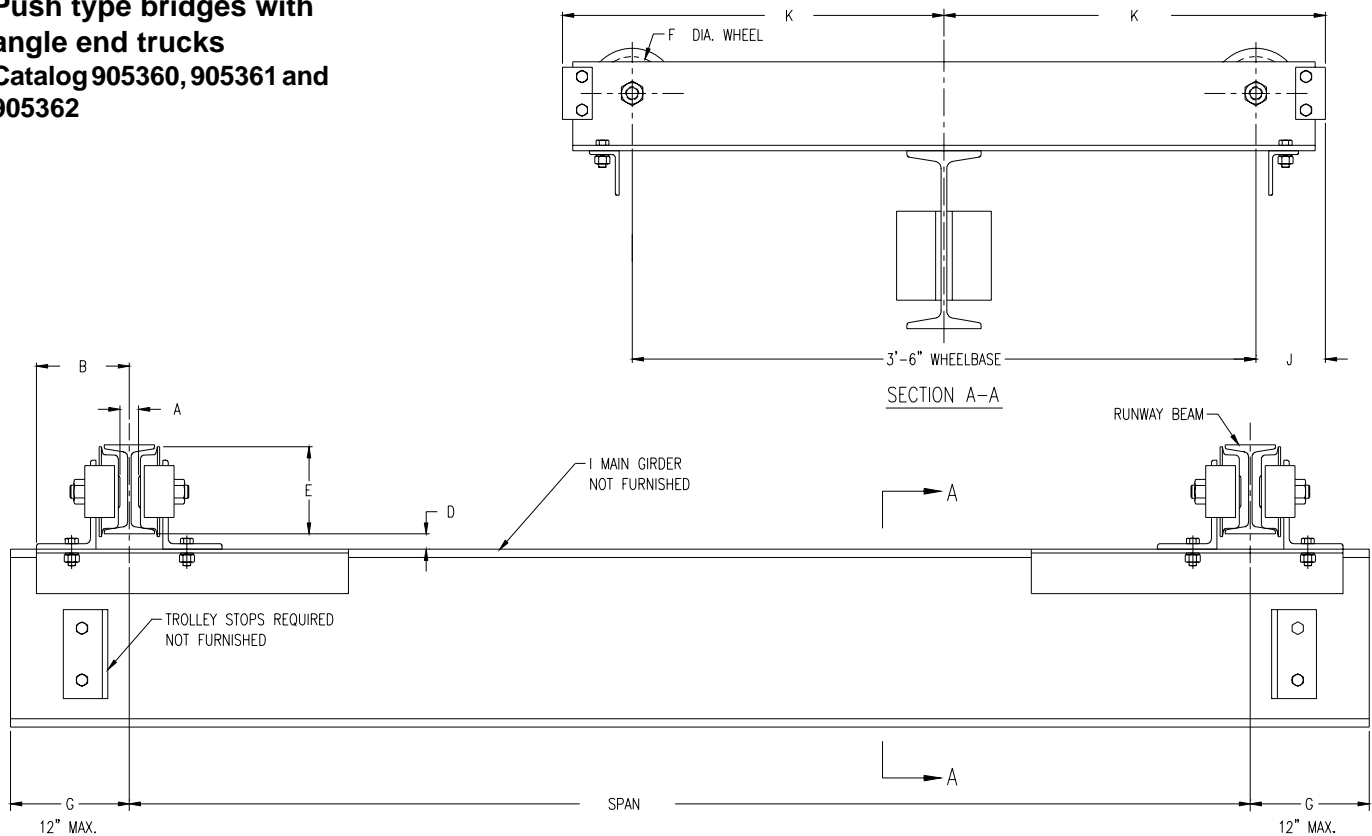

**Push type bridges with
channel end trucks**
Catalog 905368 and 905524

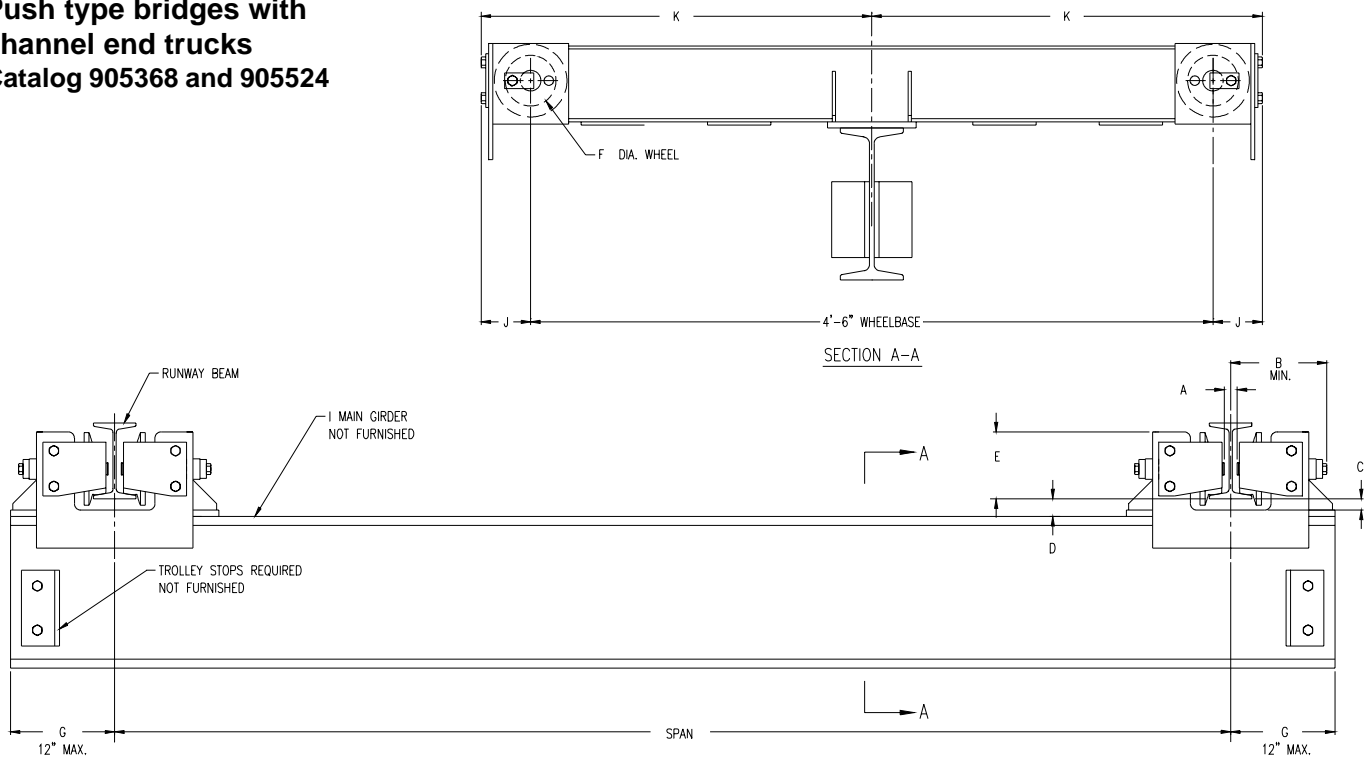

Dimension C = Dimension D Minus 1/2 inch

Bridge Girder Beam Sizes For - Push or Hand Geared Crane**

For Spans to (ft)	Rated Capacity* (tons)							
	1/4	1/2	1	1-1/2	2	3	4	5
10	S6x12.5	S7x15.3	S7x15.3	S8x18.4	S10x25.4	S12x40.8	S12x40.8	S12x40.8
12	S6x12.5	S7x15.3	S7x15.3	S10x25.4	S10x25.4	S12x40.8	S12x40.8	S18x54.7
14	S7x15.3	S7x15.3	S7x15.3	S10x25.4	S12x31.8	S12x40.8	S12x40.8	S18x54.7
16	S7x15.3	S7x15.3	S8x18.4	S10x25.4	S12x31.8	S12x40.8	S12x40.8	S18x54.7
18	S7x15.3	S7x15.3	S10x25.4	S10x25.4	S12x31.8	S12x40.8	S15x42.9	S18x54.7
20	S7x15.3	S8x18.4	S10x25.4	S12x31.8	S12x31.8	S12x40.8	S18x54.7	S18x54.7
22	S8x18.4	S10x25.4	S10x25.4	S12x31.8	S12x40.8	S18x54.7	S18x54.7	S20x66
24	S8x18.4	S10x25.4	S12x31.8	S12x40.8	S12x40.8	S18x54.7	S18x54.7	S20x66
26	S10x25.4	S10x25.4	S12x31.8	S12x40.8	S15x42.9	S18x54.7	S20x66	S24x80
28	S10x25.4	S10x25.4	S12x40.8	S12x40.8	S18x54.7	S20x66	S20x66	S24x80
30	S10x25.4	S12x31.8	S12x40.8	S18x54.7	S18x54.7	S20x66	S18x54.7C9x13.4	S24x80
32	S10x25.4	S12x31.8	S12x40.8	S18x54.7	S15x42.9C8x11.5	S18x54.7C9x13.4	S18x54.7C9x13.4	S20x66C9x13.4
34	S12x31.8	S12x40.8	S15x42.9	S18x54.7	S15x42.9C8x11.5	S18x54.7C9x13.4	S18x54.7C9x13.4	S20x66C9x13.4
36	S12x31.8	S12x40.8	S18x54.7	S15x42.9C8x11.5	S15x42.9C8x11.5	S18x54.7C9x13.4	S20x66C9x13.4	S20x66C9x13.4

* Rated capacity is based on maximum combined hoist and trolley weights of 500 pounds for 1/4, 1/2 and 1 ton hoists; 1100 pounds for 1 1/2 and 2 ton hoists; 1600 pounds for 3 and 4 ton hoists; 2000 pounds for 5 ton hoists. Bridge designed in accordance with CMAA Specification No. 74.

**Beam sizes listed are American Standard I-Beam and channel sections. Use ASTM A36 grade steel, first quality, free of rust and excessive mill scale.

Clearance Dimensions (in.) For Push Type Cranes

Product Code	Rated Capacity* (tons)	Max. Span (ft)	Runway Beam Sizes**			A	B	C	D	E	F Wheel Dia.	G Min.	H	J†	K
			Min. Beam Width	Min. Flange Width	Max. Flange Width										
Push Type Kit															
905360	1/2	30	S5x10	3	8	1-1/4	6-1/16	—	1-5/8	4-13/16	4	8	—	4-3/4	2' - 1-3/4"
	1	24				1-3/8	6-1/4		1-1/16	5-7/8	5				
905361	2	30	S6x12.5	3-3/8	8	1-1/4	6-11/16	—	1-9/16	5-13/16	4	8-1/4	14	4	2' - 7"
905362						5-1/2	1-1/8		7-13/16	15/16	1-7/16				
905368	3	36	S8x18.4	4	6-1/4	3/4	8-11/16	13/16	1-5/16	8	6-1/2	9-3/8	14-5/8	5-1/2	2' - 8-5/8"
905524	5														

**Runway beam sizes shown indicate range of beams that trucks will fit. For proper runway size, consult qualified engineer or architect.

End trucks for wider flange beams or 3-1/4" patented track are available.

Dimensions A, B, C, D and E are based on minimum beam.

† Dimension with rubber bumpers: 3 ton catalogs 905368 = 7 3/8 and 5 ton catalogs 905524 = 8-7/8.