

CHESTER HOIST

WORM DRIVE HOIST
DATA SHEET E-88AS

CAPACITY 5 TON

INTERMEDIATE HEADROOM
LUG TYPE - S

SINGLE HOOK MONORAIL
4-PART SINGLE

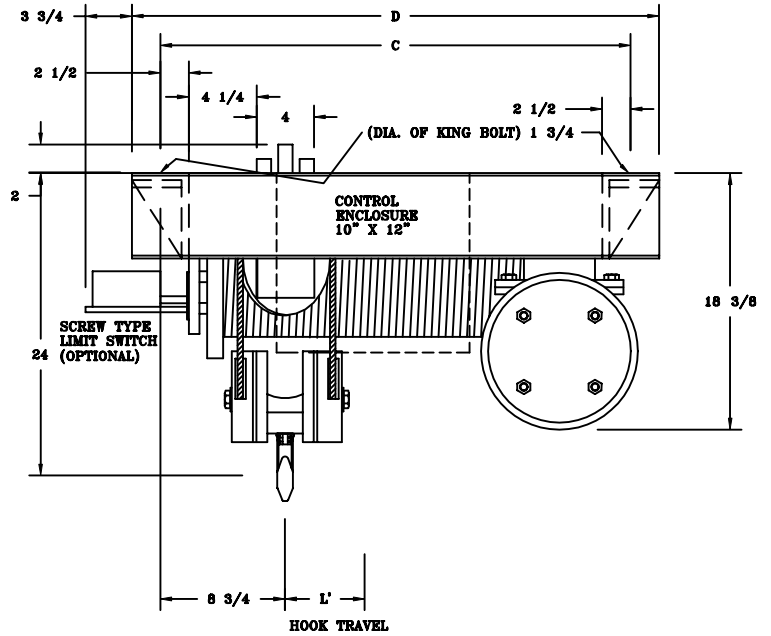
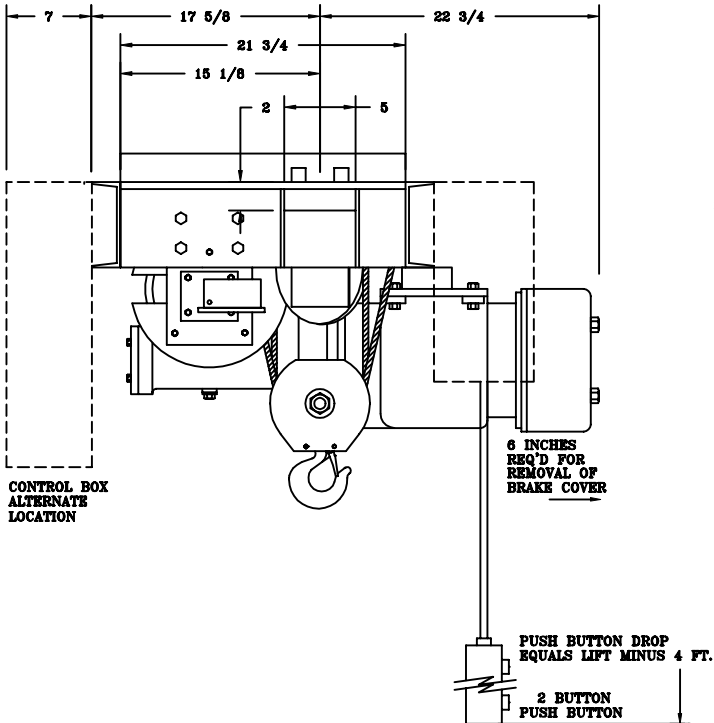

ALL DIMENSIONS IN INCHES

MODEL NUMBER	CAPACITY (lbs.)	SPEED (fpm)	LIFT (ft.)	REEVING	MOTOR (hp)	C	D	L'	APPROX. WT. (lbs.)
WD-1104WS	10000	20	23	4PS-3/8E	10 @ 1800	34 7/8	37 7/8	5	950
WD-1105WS	10000	20	35	4PS-3/8E	10 @ 1800	43 5/8	46 5/8	7	1050
WD-1105WAS	10000	20	45	4PS-3/8E	10 @ 1800	53 5/8	56 5/8	10	1150

NOTE: WHEN USING SCREW TYPE LIMIT SWITCH ADD 1 INCH TO HEADROOM.